

**RAININ**

Pipetting 360°

# EDP<sup>®</sup> 3-Plus

**Advanced Ergonomic  
Electronic Pipette**

**10 pipettes for  
volume ranges from  
0.5 µL to 20 mL**



**METTLER TOLEDO**

## TABLE OF CONTENTS

Introduction.....	1
Unpacking .....	1
Set Up / Initial Charge .....	2
Sleep Mode.....	2
Rapid Charge Stand .....	2
Tip Selection .....	2
Tip Immersion Depth.....	2
Filter.....	3
Initial Operation .....	3
Modes & Options.....	4
Basic Operation (PIPET and MULTI modes) .....	4
PIPET MODE.....	4
MULTIDISPENSE MODE .....	5
Switching on Hidden Modes, and Options .....	6
Options Common to All Modes.....	7
SND OPTION.....	7
CC OPTION .....	8
SPEED OPTION .....	8
Advanced Modes and Options.....	9
PIPET MODE.....	9
PIPET & MIX OPTION .....	9
SEQ OPTION IN PIPET MODE .....	9
FP OPTION IN PIPET MODE .....	11
MULTIDISPENSE MODE .....	12
AUTO OPTION IN MULTIDISPENSE MODE.....	12
SEQ OPTION IN MULTIDISPENSE MODE .....	12
DILUTE MODE .....	14
DILUTE & MIX OPTION.....	15
SEQ OPTION IN DILUTE MODE .....	16
TITRATE MODE .....	17
MANUAL MODE.....	18
Battery charging: Wall Power Supply .....	20
Battery charging: Rapid Charge Stand.....	20
Replacing the Battery .....	21
Tip Ejector Arm Removal .....	22
Care and Maintenance .....	22
Autoclaving.....	23
Troubleshooting and Repairs.....	23
Service, Calibration, and Repair .....	24
Replacement Parts.....	24
Specifications / Electrical specifications.....	26
Appendix A: GLP MODE .....	27
EC Declaration of Conformity.....	Inside Back Cover
Contacting Rainin .....	Back Cover

## FIGURES

Figure 1	200 $\mu$ L EDP3-Plus Pipette .....	1
Figure 2	Filter Orientation .....	3
Figure 3	EDP3-Plus Interface.....	3
Figure 4	Measuring Unknown Volume .....	19
Figure 5	Charging Devices .....	20
Figure 6	Battery Compartment and Charging Contacts .....	21
Figure 7	Replacing the Battery .....	21
Figure 8	Removing the Tip Ejector Arm .....	22

---

This device (EDP3-Plus) is intended for use only as an electronic pipette for pipetting liquids as described in this manual. It is not intended for any other use.

Note that pipette specifications and other information in this manual may be changed without prior notice.

RAININ, EDP, and LTS are registered trademarks of Rainin Instrument, LLC. ©1999-2007, Rainin Instrument, LLC. All rights reserved. EDP3-Plus Pipettes are manufactured under U.S. patents 4,671,123, 4,905,526, 5,187,990, 5,614,153, 6,254,832 B1 and 6,299,841. LTS LiteTouch Tip Ejection System is protected by U.S. patents 6,168,761 B1 and 6,171,553 B1. Other U.S. and national patents pending.

## Introduction

---

EDP3-Plus electronic pipette is an enhanced version of the original RAININ EDP3. It offers advanced operation with additional modes and options not found in the original EDP3 Model.

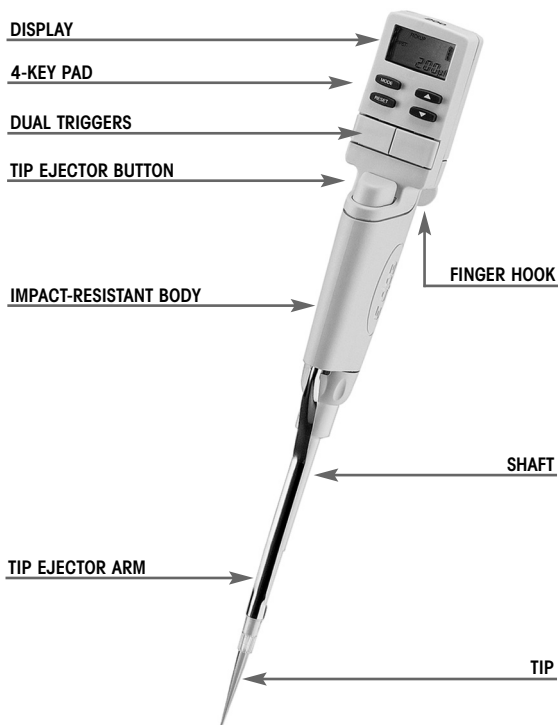

**FIGURE 1 200 µL EDP3-PLUS PIPETTE**

## Unpacking

---

The EDP3-Plus package should contain:

1. EDP3-Plus Electronic Pipette with Battery
2. Operator Manual
3. Quick Reference Guide
4. Performance Check Report / Warranty Card
5. Sample Tips

The Wall Power Supply or the Rapid Charge Stand (one of which MUST be purchased to recharge the EDP3-Plus battery) are shipped in a separate box.

Unpack and check the contents against this list. If anything is missing, call Technical Service: 800-543-4030.

If any damage is evident, file a claim with the shipping carrier, who is responsible for damage incurred in transit. Save the shipping packages if you file a claim.

## **Set Up / Initial Charge**

---

EDP3-Plus is shipped with the battery charged. But as it may have been stored before delivery, charge the battery for about 15 minutes initially – you can use EDP3-Plus while it is charging. Connect the wall power supply to a power outlet matching the line voltage printed on the label:

120 VAC/60 Hz	US	220 VAC/50 Hz	Europe
240 VAC/50 Hz	UK	100 VAC/50 Hz	Japan

Connect the other end of the cord to the power socket on the back of EDP3-Plus. After 15 minutes the pipette will be charged enough for a typical day's pipetting, and fully charged after approximately 60 minutes. The battery symbol outline in the top right corner of the display flashes while charging.

## **Sleep Mode**

---

To extend battery life, the EDP3-Plus display "sleeps" after ten minutes of inactivity; i.e. ten minutes after the last keystroke or trigger press. Press any key or trigger to "wake" the display.

## **Rapid Charge Stand**

---

E3-RCS Rapid Charge Stand charges three EDP3-Plus pipettes in sequence. With one EDP3-Plus on the stand, charging proceeds as if the wall power supply were connected directly to the pipette. But when charging more than one EDP3-Plus, the one placed on the stand first will be charged first, then the others sequentially. To charge a particular pipette, remove other pipettes and place the desired pipette in the stand. See page 20 for more information.

## **Tip Selection**

---

To ensure proper, leak-free fit and conformance to specifications, use only RAININ tips with EDP3-Plus pipettes. When loading tips, press the EDP3-Plus shaft into the end of the tip with only sufficient force to make a positive seal.

## **Tip Immersion Depth**

---

Recommended depths for tip insertion into sample are shown below.

<b>Model Volume</b>	<b>Immersion Depth</b>
10 $\mu$ L	1 - 2 mm
20 $\mu$ L - 100 $\mu$ L	2 - 3 mm
200 $\mu$ L - 2000 $\mu$ L	3 - 6 mm
5000 $\mu$ L - 20 mL	6 - 10 mm

Tip immersion depth is important. If these depths are exceeded, the volume measured may be inaccurate, possibly out of specification. Tip angle is also important for best results: when pipetting, always hold EDP3-Plus within 20 degrees of vertical.

## Filter

EDP3-Plus 5000  $\mu\text{L}$ , 10 mL and 20 mL pipettes use a filter in the end of the shaft to help prevent liquid entering the shaft and contaminating the piston. Using such a filter is important when pipetting large volumes. Replace the filter if it gets wet.

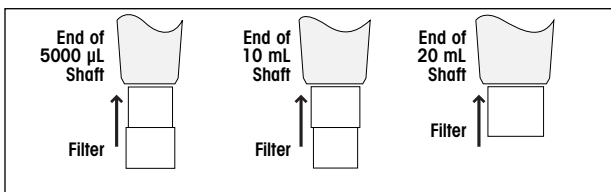

**FIGURE 2 FILTER ORIENTATION**

The 5000  $\mu\text{L}$  and 10 mL pipettes use the same filter, oriented as shown in the diagram above. For 5000  $\mu\text{L}$ : insert the small diameter into the shaft. For 10 mL: insert the large diameter into the shaft. Filter part numbers are 6190-164 (pack of 100) and 6190-165 (pack of 1000).

The filter for 20 mL is a cylinder which can be installed in either orientation. Filter part numbers: 6190-221 (pack of 100) and 6190-222 (pack of 500).

## Initial Operation

Before initial operation you should charge EDP3-Plus for about 15 minutes as described on page 2.

Before pipetting for the first time, take time to familiarize yourself with the key functions, and practice scrolling through modes and options as described on the following pages. The first time the EDP3-Plus pipette is used, it will default to **PIPET** mode. If not, press the **MODE** key until **PIPET** shows on the LCD (see below).

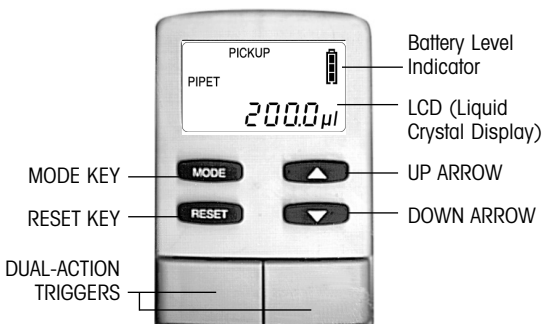

**FIGURE 3 EDP3-PLUS INTERFACE – (200  $\mu\text{L}$  MODEL SHOWN)**

## Modes & Options:

EDP3-Plus has six modes of operation, with several options per mode, listed below.

BASIC MODES	OPTIONS AVAILABLE				
PIPET	& MIX	SEQ	FP	CC	SPEED
MULTI	AUTO	SEQ			SPEED SND
ADVANCED MODES	(SWITCH ON AND OFF IN MULTI MODE)				
DILUTE	& MIX	SEQ		CC	SPEED
TITRATE				CC	SPEED
MANUAL				CC	SPEED
GLP	(SEE APPENDIX A)				

## Abbreviations

- & MIX:** Mix. (Piston moves up and down as trigger is held, mixing the contents of the tip)
- SEQ:** Volume Sequencing (a sequence of different volumes is aspirated or dispensed, depending on mode)
- FP:** Fixed Point (up to six discrete volumes can be programmed for routine work or standard protocols)
- CC:** Cycle Counter (each pipetting cycle is counted)
- SPEED:** Aspiration/Dispense speed 1 (slow) to 10 (fast)
- AUTO:** Autopace (automatic repeat dispensing at settable time interval after trigger press)
- SND:** Sound **ON / OFF / VOLUME** - 1 (soft) to 7(loud)
- GLP:** Good Laboratory Practice (user logs)

The next few pages describe 1. basic operation of EDP3-Plus in **PIPET** and **MULTI** modes, without options, 2. switching on advanced modes, and 3. advanced operation using all modes and options.

## Basic Operation — PIPET & MULTI modes

EDP3-Plus is shipped ready for basic operation. **PIPET** and **MULTI modes** are switched on, other modes are hidden. The hidden modes can be switched on as needed in **MULTI** mode, described later.

## PIPET MODE

### Select Volume with Arrow Keys

**ARROW** keys operate when the piston is at the zero point, ready to pick up sample. The **DOWN ARROW** reduces, and the **UP ARROW** increases, the volume. Touch either **ARROW** key to change volume by one increment. Press and hold the **ARROW** key: the volume changes while you hold down the key, slowly at first then with increasing speed.



## Volume Scrolling

While pressing the **ARROW** key, note the changing volume setting pauses at 25%, 50%, and 75% of the pipette's nominal volume, then continues at the faster rate.

At maximum volume, pressing the **UP ARROW** rolls the volume over to begin again at the minimum volume (0.5% of maximum volume). Pressing the **DOWN ARROW** at the minimum volume rolls over to the maximum volume. This allows rapid volume change from high to low or vice versa. If you roll over through the high or low values, the display pauses briefly at the maximum and minimum volumes, as it rolls over.

## Aspirate or Dispense with Trigger

When the desired volume is set, attach a tip – press the shaft into the end of the tip with only enough force to make a positive seal. Immerse the tip end into the sample and touch either trigger to aspirate. To dispense, touch the tip end against the vessel side wall, and press either trigger. After blowout, remove the tip from the vessel, and press the tip ejector button to discard the used tip.

Press either trigger once to aspirate, then press either trigger again to dispense. You can even press both triggers at once to aspirate and dispense – use the trigger which is most convenient.

## MULTIDISPENSE MODE

1. Press **MODE** button until **PICKUP MULTI** shows on the LCD.
- 2a. Set aliquot size using either **ARROW KEY**. EDP3-Plus automatically computes the number of aliquots that can be dispensed and shows the number (8x, 6x, etc.) in the lower left of the display. When aliquot size is set, and trigger is pressed EDP3-Plus aspirates the maximum volume of sample needed. To ensure accuracy on the last aliquot, EDP3-Plus always picks up slightly more sample than will be pipetted.

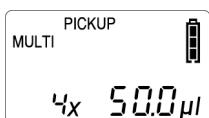

MULTIDISPENSE mode selected on a 200 µL EDP3-Plus with 50 µL aliquot volume

OR:

- 2b. Select number of aliquots with **RESET/ARROW** keys. Press either **ARROW KEY** to set aliquot size. Then set the total number of aliquots you wish to dispense by momentarily pressing **RESET**. When the display flashes, press the **ARROW KEY** to set the number of aliquots you wish to dispense. (Note you cannot increase the number of aliquots above the default maximum).

Press the trigger to "enter" the settings and start the aspiration. EDP3-Plus will pick up only the amount of sample necessary to accurately dispense the number of aliquots selected.

After aspiration, each time you press a trigger, one aliquot is dispensed. Touch off the droplets from each tip against the vessel wall to ensure accuracy as each aliquot is dispensed.

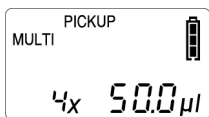

Multidispense: Pickup

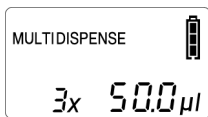

Multidispense: Dispense

The counter will count down to zero and **RESET** will flash on the display. Press the **RESET** key or double-click either trigger to expel the extra liquid remaining in the tip.

In **MULTI** mode you can dispense all the liquid in the tip at any time by pressing **RESET**.

## Switching-on Hidden Modes, and Options

As shipped, EDP3-Plus will operate in “basic” configuration. Clicking the **MODE** key toggles between **PIPET** and **MULTI** modes. Advanced modes (**DILUTE**, **TITRATE**, **MANUAL** and **GLP**) are hidden.

Click the **MODE** key to reach **MULTI** mode, then press and hold the **MODE** key to reach the options and hidden modes.

Click **MODE** repeatedly to cycle through the options available in **MULTI** mode: **SPEED**, **AUTO**, **SEQ** – then the hidden modes (in order to switch them on), **DILUTE**, **TITRATE**, **MANUAL**, **GLP** – then the **SND** option (sound).

When a hidden mode is displayed, switch it on (or off) using the **ARROW** keys. Then press **RESET** or a trigger to lock the mode state. (Pressing a trigger also starts a cycle in the selected mode.)



**DILUTE** mode switched on in **MULTI** mode using **ARROW** keys

If all modes are switched on, pressing the mode key repeatedly cycles through them as follows:

**PIPET – MULTI – DILUTE – TITRATE – MANUAL – GLP**

Operation in all modes is shown in the pages following.

Within each mode, pressing and holding the **MODE** key opens the **OPTIONS** menu appropriate for that mode. Switch the options on or off (and set increasing or decreasing values for some options) with the **ARROW** keys. To lock options in memory press **RESET** or a **TRIGGER**. Pressing a **TRIGGER** starts the cycle as well.



## Options Common to All Modes

---

### **SND OPTION**

#### **Sound – on/off/volume level**

In MULTIDISPENSE mode, press and hold the **MODE** key to reach the options menu. Then press the **MODE** key repeatedly until “SND” is displayed. Use either **ARROW key** to turn this option on or off and set the volume level between 1 (soft) and 7 (loud). The on/off state and volume level are set for all modes.

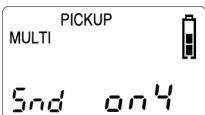

SND OPTION turned on with volume set to level 4

With **SND** switched on, the following sounds are heard:

#### **PIPET MODE**

End of pickup: **HIGH BEEP**

End of dispense: **LOW BEEP**

Return to home: **DOUBLE HIGH BEEP**

#### **MULTIDISPENSE MODE**

End of pickup: **HIGH BEEP**

After each dispensed aliquot: **HIGH BEEP**

After last aliquot: **DOUBLE HIGH BEEP, ONE EXTRA LOW BEEP**

Bottom of blowout: **LOW BEEP**

Return to home: **DOUBLE HIGH BEEP**

#### **DILUTE MODE**

After all pickups 1 to n-1: **HIGH BEEP**

After last pickup: **DOUBLE HIGH BEEP, ONE EXTRA LOW BEEP**

Bottom of blowout: **LOW BEEP**

Return to home: **DOUBLE HIGH BEEP**

#### **MANUAL MODE**

After full pickup: **HIGH BEEP**

At end of dispense: **HIGH BEEP**

Bottom of blowout: **LOW BEEP**

Return to home: **DOUBLE HIGH BEEP**

#### **TITRATE MODE**

After full pickup: **HIGH BEEP**

At end of dispense: **HIGH BEEP**

Bottom of blowout: **LOW BEEP**

Return to home: **DOUBLE HIGH BEEP**

#### **GENERAL – ALL MODES**

Key press: **SHORT CLICK**

Low battery warning: **LOUD WARBLE** (continuous alternating high/low beep) after every motor movement when there is a low battery condition, even when **snd** is turned off.

Error: **LOUD WARBLE** when any error condition is present, even if **SND** is turned off.

## **CC OPTION**

### **Cycle counter. Each pipetting cycle is counted**

In any mode except MULTIDISPENSE, press and hold the **MODE** key to reach the options menu. Then press the **MODE** key repeatedly until "cc" is displayed. Use either **ARROW** key to turn this option on or off. The display shows incrementing pipetting cycles in the lower left, up to 999, then rolls over to 0. You can reset the counter to 0 at any time by pressing and holding **RESET** until the display reads 0.

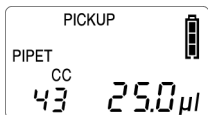

**CC OPTION selected with 25 µL set volume and 43 cycles counted**

To start the count at any cycle number, press **RESET** momentarily. This allows the desired cycle number to be set with **ARROW** keys.

## **SPEED OPTION**

### **Aspiration/dispense speed 1 (slow) to 10 (fast).**

EDP3-Plus is delivered with the **SPEED** option set to 10\*. This setting can be changed for any mode as desired. High speeds (9 or 10) are best for aqueous samples and slower speeds are useful for viscous, foaming, or shear-sensitive samples.

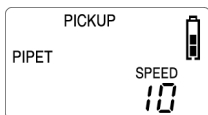

**SPEED set to 10 in PIPET mode**

In any mode, press and hold the **MODE** key to reach the **OPTIONS** menu. Then press the **MODE** key repeatedly until "SPEED" is displayed. Use the **ARROW** keys to set the desired speed.

\*The maximum speeds of larger volume models are limited to prevent "fountaining" or air intake when aspirating.

Large-volume maximum speeds: 5000 µL–8 , 10 mL–8, 20 mL–6.

<b>SPEED SETTING</b>	<b>FULL-SCALE PICKUP</b>	<b>FULL-SCALE DISPENSE</b>	<b>DELAY BEFORE BLOWOUT</b>	<b>BLOWOUT DURATION</b>	<b>HOLD AT END (CONSTANT)</b>
10	0.7 s.	0.7 s.	0.0 s.	0.13 s.	1.0 s.
9	1.0 s.	1.0 s.	0.4 s.	0.22 s.	1.0 s.
8	1.5 s.	1.5 s.	0.6 s.	0.30 s.	1.0 s.
7	1.9 s.	1.9 s.	0.8 s.	0.38 s.	1.0 s.
6	2.4 s.	2.4 s.	0.9 s.	0.50 s.	1.0 s.
5	2.8 s.	2.8 s.	1.1 s.	0.52 s.	1.0 s.
4	3.2 s.	3.2 s.	1.5 s.	0.58 s.	1.0 s.
3	3.8 s.	3.8 s.	1.7 s.	0.69 s.	1.0 s.
2	4.5 s.	4.5 s.	1.9 s.	0.80 s.	1.0 s.
1	5.3 s.	5.3 s.	2.5 s.	1.04 s.	1.0 s.

Table applies to EDP3-Plus in PIPET mode.

## Advanced Modes and Options

### PIPET MODE

Basic operation of PIPET mode is described on pages 4-5.

OPTIONS AVAILABLE: & MIX — CC — SEQ — FP — SPEED

### PIPET & MIX OPTION

Piston moves up and down while the trigger is pressed, mixing the sample and another liquid in the tip

In PIPET mode, press and hold the **MODE** key to reach the **OPTIONS** menu. Then click the **MODE** key until “& MIX” appears on the display. The first time used, the display will flash “OFF”. Use the **ARROW** keys to turn on the option and set the volume to be mixed, from 5% to 100% of nominal volume.

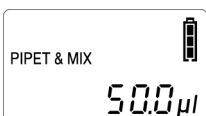

PIPET & MIX OPTION selected with 50 µL mix volume

Press **RESET** and set the aspiration volume with the **ARROW** keys. Then immerse the tip end into the sample and press either trigger to aspirate the set volume.

Pressing and holding either trigger dispenses the set volume, then mixes the mix volume in the tip by moving the piston up and down while the trigger is pressed. To stop mixing and dispense the tip contents, release the trigger. Alternately, a single touch to the trigger dispenses without any mixing occurring.

To turn off the **MIX** option, hold the **MODE** key until “& MIX” is displayed, then scroll the mix volume with the **ARROW** keys to the minimum or maximum value. Releasing and pressing the last **ARROW** key turns the option off.

### SEQ OPTION IN PIPET MODE

**Volume Sequencing (in PIPET mode a sequence of up to 16 volumes is picked up and dispensed)**

In PIPET mode, press and hold the **MODE** key to reach the options menu. Then press the **MODE** key repeatedly until “SEQ” is displayed. Turn this option on using either **ARROW** key. Then press the **RESET** key to enable the sequential volumes to be set.

The first time **SEQ** option is invoked, the display shows “n1” with the EDP3-Plus nominal volume as a default. Change this volume as needed with the **ARROW** keys, then use **RESET** to scroll through the sequence volumes, setting values with the **ARROW** keys. The following example (setting three sequential volumes) assumes that volume sequencing has not been invoked before. After volume sequencing has been invoked, all sequential volumes will be stored in memory. Up to 16 volumes can be stored in a sequence.

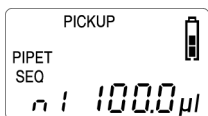

Display shows "n1" (first sequential volume) set at the nominal pipette volume, in this example 100 µL

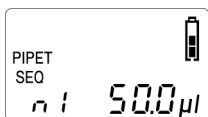

First volume is reset to 50 µL with ARROW keys. (When editing a sequence, the volume flashes and the PICKUP symbol disappears.) Press RESET to reach the next volume

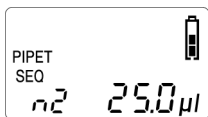

Second volume is changed from 0.0 µL to 25 µL with ARROW keys. Press RESET to reach the next volume

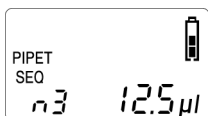

Third volume is changed from 0.0 µL to 12.5 µL with ARROW keys. Press RESET to reach the next volume

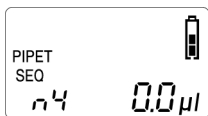

To finish the series, leave volume at 0.0 µL and press RESET to begin volume sequencing in PIPET mode

When all volumes in the sequence have been set as shown above, pressing **RESET** will let you begin volume sequencing in **PIPET** mode. With a tip attached and immersed in sample, press either trigger to pick up the first volume, then dispense that volume into a vessel using either trigger. Press the trigger again to pick up the second volume in the sequence, and dispense it with either trigger, and so on. After dispensing the last volume, the sequence begins over.

Turn the **SEQ** option off by holding the **MODE** key to open the **OPTIONS** menu, and pressing the **MODE** key repeatedly until you reach the **SEQ** menu. Then press either **ARROW** key.

#### Notes:

1. Volume sequencing can be started from any point in the sequence, by scrolling through volumes with the **RESET** key, then pressing either trigger at the desired starting volume.
2. You can edit a previously-stored sequence of, for example, 10 volumes to have only four volumes, by setting new values as needed for the first four volumes, then setting zero as the fifth value. If at some future point you enter a non-zero value as the fifth volume, volumes 6 through 10 of your original stored sequence are recalled from memory.
3. With **SEQ** and **CC** options both selected, the same display segments are used to show both sequence index number and cycle count. Normally in **PIPET** mode with **SEQ** and **CC** both enabled, the **CC** value only is shown.

To see the SEQ index number during the pipetting sequence, momentarily press RESET enough times until the display shows one of the sequence index numbers at the PICKUP (HOME) position, then start the sequence. The SEQ number will now show at HOME and the CC number will show when the piston is away from HOME.

## FP OPTION IN PIPET MODE

**Fixed Volume Pipetting (up to six discrete volumes can be loaded for routine work or standard protocols)**

In PIPET mode, press and hold the MODE key to reach the OPTIONS menu. Then press the MODE key repeatedly until "FP" is displayed. If FP option is off, switch it on with either ARROW key, then press and release the MODE key. The display will read "FP1" with flashing "-----" in the volume area.

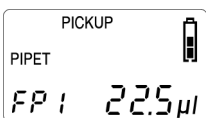

Set the first fixed volume with the ARROW keys. In this case 22.5 µL was set for FP1

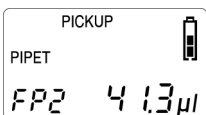

Press MODE to scroll to the next fixed volume, and set with the ARROW keys. In this case 41.3 µL was set for FP2

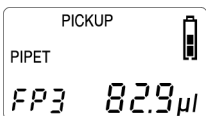

Press MODE to scroll to the next fixed volume, and set with the ARROW keys. In this case 82.9 µL was set for FP3

When the desired number of FP volumes have been set, press RESET to begin pipetting with the volume set in FP1. In this mode normal operation of the ARROW keys is suspended. The UP ARROW scrolls through the fixed volumes in ascending order FP1, FP2, FP3, etc, then rolls over after the last FP volume to start again, and the DOWN ARROW scrolls through the fixed volume settings in descending order, rolling over after the first FP volume.

Turn the FP option off by holding the MODE key to open the OPTIONS menu, and pressing the MODE key repeatedly until you reach "FP ON". Then press either ARROW key.

### Notes:

1. The ARROW keys select the next FPn in sequence, NOT the next higher or lower volume.
2. If the FP option is set "on", scrolling through the PIPET mode options by holding then repeatedly pressing the MODE key also scrolls through all FP volumes, even where no entry was made.

## MULTIDISPENSE MODE

For basic operation, MULTIDISPENSE mode , see pages 5-6.

OPTIONS AVAILABLE: AUTO — SEQ — SND — SPEED

MODE SWITCH-ON: DILUTE — TITRATE — MANUAL — GLP

## AUTO OPTION IN MULTI MODE

**Autopace: Automatic repeat dispensing at settable time interval with one trigger press.**

AutoPace allows multiple aliquots of the same volume to be dispensed repeatedly at equal time intervals after the dispense trigger is pressed once.

In MULTI mode, press and hold the MODE key to reach the OPTIONS menu. Then click the MODE key until "AUTO" appears on the display. The first time used, the display will flash "OFF". Use the ARROW keys to set the time interval between dispenses. The range is 0.2 seconds to 25 seconds, in 0.1 second increments.

When the time interval is set, press either trigger to pick up the set volume. Then press the trigger again to begin dispensing automatically at the set time interval. Pressing either trigger pauses autodispensing until a trigger is pressed again, when autodispensing restarts. At the end of the last dispensed aliquot, press RESET to begin the next pickup.

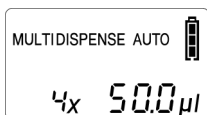

Autodispensing set in MULTI mode

Note: AUTO symbol flashes when paused and is steady when active

## SEQ OPTION IN MULTI MODE

**Volume Sequencing (in MULTIDISPENSE mode a sequence of up to 16 volumes is dispensed from a pickup)**

In MULTI mode, press and hold the MODE key to reach the OPTIONS menu. Then press the MODE key repeatedly until "SEQ" is displayed. Turn this option on using either ARROW key. Then press RESET.

The first time SEQ option is invoked, the display shows 1x with the nominal full volume of the pipette model.

To set sequential volumes, press RESET to scroll through the sequenced volumes, setting values with the ARROW keys.

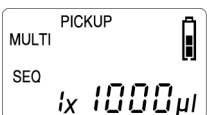

Display showing the SEQ option invoked for the first time on a 1000 µL model E3

Press **RESET** to begin volume sequencing in **MULTIDISPENSE** mode. The display shows the addition of all volumes to be sequenced, and the number of times the total volume can be picked up and the sequences dispensed.

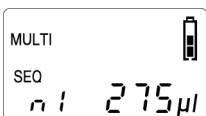

First volume is set to 275  $\mu\text{L}$  with **ARROW** keys. (When editing a sequence, the volume flashes and the **PICKUP** symbol disappears.) Press **RESET** to reach the next volume

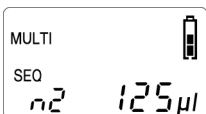

Second volume is set to 125  $\mu\text{L}$ . Press **RESET** to reach the next volume

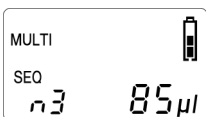

Third volume is set to 85  $\mu\text{L}$ . Press **RESET** to reach the next volume

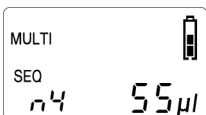

Fourth volume is set to 55  $\mu\text{L}$ . Press **RESET** to reach the next volume

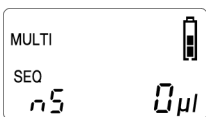

To finish the series, leave volume at 0.0  $\mu\text{L}$  and press **RESET** to begin volume sequencing in **MULTIDISPENSE** mode.

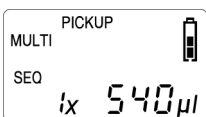

Sum of sequenced volumes and number of times the total volume can be picked up.

Press either trigger to pick up the total volume. Press either trigger again to dispense the first volume. Continue pressing and releasing a trigger to dispense all volumes sequentially. After the last volume in the sequence is dispensed, (display shows 0x with **RESET** flashing) press **RESET** to start the next pipetting cycle.

If the sum of the sequential volumes is more than the full-scale pickup volume of the pipette, the sequential volume series is split into two or more pickups. This situation is shown by a horizontal dash in front of the number of pickups.

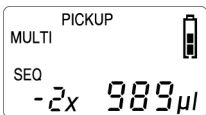

Display shows that more than one pickup is needed for the sum of the sequenced volumes

In the example, the sum of the sequenced volumes is 1045. The first pickup volume is 989 (sum of all sequence volumes that can be picked up – which must be less than the pipette's volume).

Press the trigger to pick up the first sum volume, then press the trigger repeatedly to dispense all the sequenced volumes. Press **RESET** after the last volume in the sequence.

Then the display shows the pickup volume needed to complete the sequence (in this case the sum of 34 µL and 22 µL).

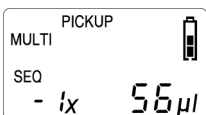

Display shows second pickup needed to complete the sequence

Press the trigger to pickup the second sum volume, then press the trigger repeatedly to dispense all the sequenced volumes. Press reset after the last volume in the sequence.

After volume sequencing has been invoked, all sequential volumes will be stored in memory. Up to 16 volumes can be stored in a sequence.

**Note: SEQ and AUTO options can be used at the same time in MULTI mode.**

## DILUTE MODE

In **MULTI** mode, press and hold the **MODE** key to reach the options and hidden modes, click **MODE** until **DILUTE** is reached, then switch on **DILUTE** mode with the **ARROW** key. Press **RESET** and click **MODE** until **DILUTE** is reached.

In **DILUTE** mode EDP3-Plus picks up first the diluent ("n1"), then an air gap ("Air"), then the sample ("n2"), and dispenses the diluent and sample all at once. The first time **DILUTE** mode is used the n1 value is 25% of nominal volume, and the n2 value is 50% of nominal volume. The air gap is fixed.

Press the **UP** or **DOWN ARROW** until the desired value is shown for "n1", the diluent volume.

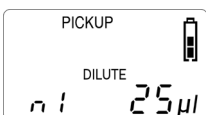

DILUTE mode with 25µL set for n1, the diluent volume



Press the **RESET** key to allow "n2", the sample volume, to be set with the **UP** or **DOWN ARROW**.

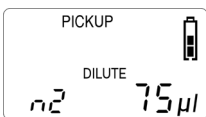

Sample volume, n2, set to 75µL

When both diluent and sample volumes have been set, press **RESET** to begin operation in **DILUTE** mode. Press either trigger to pick up the diluent volume. Then lift the tip from the diluent and press the trigger again to pick up a fixed volume of air.



Fixed volume of air is picked up to separate the diluent and sample.

Place the tip end into the sample and press either trigger again to pick up the sample volume. Now the diluent, air gap and sample are in the tip, and the display shows the total volume of the diluent and the sample volumes.

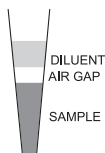

Total volume of diluent and sample

To dispense the diluent and sample together, press either trigger.

**DILUTE** mode can also be used with the following options:

& MIX    CC    SEQ    SPEED

## **DILUTE & MIX OPTION**

### **Piston moves up and down mixing tip contents**

In **DILUTE** mode, press and hold the **MODE** key to reach the options menu. Then click the **MODE** key until "& MIX" appears on the display.

The first time used, the display will flash "OFF". Use the **ARROW** keys to set the volume to be mixed. Allowable range is from 5% to 100% of the nominal volume.



**DILUTE** mode with **MIX** option set to mix 100 µL (same as sample plus diluent, in this case)

When the MIX volume is set, operation is the same as described for DILUTE, except that pressing and holding the trigger dispenses the tip contents then mixes the mix volume in the tip. Releasing the trigger stops mixing and dispenses the tip contents.

Alternately, a single touch to the trigger dispenses completely without any mixing occurring.

## **SEQ OPTION IN DILUTE MODE**

**Volume sequencing (in DILUTE mode a sequence of up to 16 volumes can be aspirated then dispensed all at once).**

In DILUTE mode, press and hold the MODE key to reach the OPTIONS menu. Then press the MODE key repeatedly until "SEQ" is displayed. Turn this option on using either ARROW key. Then press the RESET key. Use the UP/DOWN arrow keys to set values for the sequenced volumes.

**Note there is no "air" setting when using the SEQ option, but any sequence volume can be used for an air gap.**



DILUTE mode with SEQ option. 100 µL set as first sequential volume

Press RESET and then use the UP/DOWN arrow keys to set the next volume in the series.

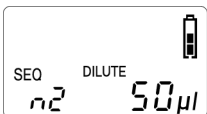

UP/DOWN arrow keys used to set second sequential volume of 50 µL

Continue using the RESET and UP/DOWN arrow keys to set the remaining volumes in the series. Finish the series at any point by entering "0" as the value.



UP/DOWN arrow keys used to set third sequential volume of 100 µL



UP/DOWN arrow keys used to set fourth sequential volume of 50 µL



UP/DOWN arrow keys used to set fifth sequential volume of 100 µL



UP/DOWN arrow keys used to set last sequential volume, by entering "0"

Press either trigger to begin operation. Each sequential volume is picked up in turn by another trigger press. Then the display will show the addition of all the volumes, ready to dispense.



Total of all sequence volumes shown, ready to dispense

Press either trigger to dispense all dilution sequence volumes.

### Notes:

1. If you included air gaps in the sequential volume settings, the value displayed may not reflect the actual volume of liquid in the tip. You must subtract the addition of all air gaps from this total.
2. SEQ and MIX options can be used together in DILUTE mode. With SEQ and MIX option both selected in DILUTE mode, operation is the same as described above for DILUTE with SEQ option, except that pressing and holding the trigger when dispensing the tip contents, first dispenses the tip contents then mixes the mix volume in the tip. Releasing the trigger stops mixing and dispenses the tip contents.
3. If SEQ and CC options are both selected, the same display segments are used for both options.

In DILUTE mode the CC value is shown at the pickup (home) position, and the SEQ index number is shown during aspiration. Then the CC number is shown during dispense and increments as the piston reaches the home position.

## TITRATE MODE

In MULTI mode, press and hold the MODE key to reach the options and hidden modes, click MODE until TITRATE is reached, then switch on TITRATE mode with the ARROW key. Press RESET and click MODE until TITRATE is reached.

Titration is simple with EDP3-Plus. In TITRATE mode, any volume up to full nominal volume can be aspirated and then titrated very accurately under trigger control.

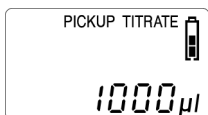

TITRATE mode showing full nominal volume. Change this volume with UP/DOWN arrow keys if desired

A settable fast-dispense feature (**Fd**) allows rapid dispensing of the set **Fd** volume then titration under trigger control as described above. Pressing **RESET** once (twice if **cc** option is also on) allows you to set the fast-dispense volume if desired.

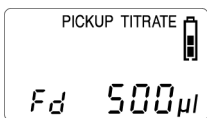

Fast-dispense volume of 500 µL set

Press either trigger to begin titration. The set aspirate volume is picked up. Pressing and releasing either trigger first dispenses the **Fd** volume (if set) then titrates the EDP3-Plus's smallest increment (1/1000th of the nominal volume).

Holding the trigger titrates the sample at increasing speed, until the trigger is released again.

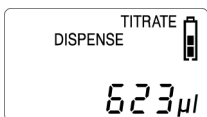

Display always shows actual volume titrated

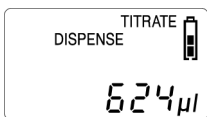

Trigger pressed and released to titrate a single incremental volume

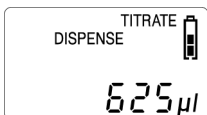

Trigger pressed and released to titrate a single incremental volume

## MANUAL MODE

In **MULTI** mode, press and hold the **MODE** key to reach the options and hidden modes, click **MODE** until **MANUAL** is reached, then switch on **MANUAL** mode with the **ARROW** key. Press **RESET** and click **MODE** until **MANUAL** is reached.

Using the **ARROW** keys, select the maximum sample size you wish to pipette. The first trigger you touch is the **ASPIRATE** trigger and the other becomes the **DISPENSE** trigger.

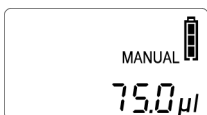

**MANUAL** mode selected with 75 µL as the set pickup volume

To pick up the set volume, immerse the tip into sample and press and hold the **ASPIRATE** trigger. This resets the display to zero, then the volume increases until the set volume is picked up. Press and hold the **DISPENSE** trigger until the desired volume is dispensed. To blow out any remaining sample press the **RESET** key momentarily or, if at **HOME** position double-click the dispense trigger.

You can also pick up or dispense one increment at a time by momentarily pressing the appropriate trigger. After setting maximum sample size and immersing the tip into sample, the first time you press and release the **ASPIRATE** trigger the display will zero, then show the smallest possible increment of volume for the particular EDP3-Plus model.

Then each time you press the **ASPIRATE** trigger momentarily, one increment of sample is drawn into the tip: If you press and hold the trigger the aspiration rate will increase to the preset speed. When you release the trigger, aspiration will stop. The display always reads the actual amount of sample in the tip. To dispense, press the **DISPENSE** trigger. To complete the blowout stroke, double-click the **DISPENSE** trigger (or click **RESET**).

## Measuring Unknown Volumes in Manual Mode

Set the maximum volume with the **ARROW** key. Immerse the tip end into the unknown volume. Press either trigger to start aspirating and measuring. The display will set to zero and then increase while you hold the trigger, and EDP3-Plus will begin aspirating. Click or press and hold the trigger until the complete volume to be measured is inside the tip. If you overshoot and pick up some air after the liquid, just click the other trigger (**DISPENSE**) until the air is expelled and the liquid is level with the tip orifice.

When all the liquid is in the tip with no air visible, the display shows the exact volume of the liquid picked up.

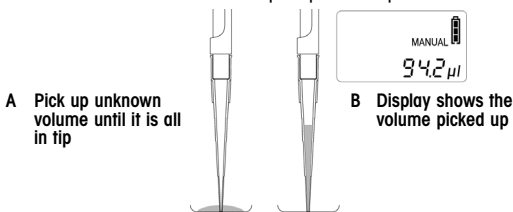

**FIGURE 4 MEASURING UNKNOWN VOLUME**

The display can be zeroed with liquid in the tip, if desired (e.g. to measure a volume of one sample then a volume of another). Press **RESET** for more than one second, or press the **DOWN ARROW** to zero the display after measuring the first volume. Then press a trigger to measure the second pickup. Press the up arrow to see the total of the two measurements.

## GLP MODE

Refer to Appendix A: GLP Mode, in the back of this manual.

## **Battery Charging: Wall Power Supply**

---

Unlike other types of battery, the Li-Ion battery in the EDP3-Plus has no “memory effect” and does not need to be fully discharged every month or so. It will provide up to 3000 full-stroke cycles (fewer in large-volume-range models) before needing to be recharged. To recharge EDP3-Plus, connect the wall power supply to a power outlet matching the line voltage printed on the label:

120VAC 60Hz	US	220VAC 50Hz	Europe
240VAC 50Hz	UK	100VAC 50Hz	Japan

Connect the other end of the cord to the power socket on the back of EDP3-Plus. After 15 minutes the instrument will be charged enough for a typical day’s pipetting, and fully charged after approximately 60 minutes. The battery symbol outline in the top right corner of the display flashes while charging.

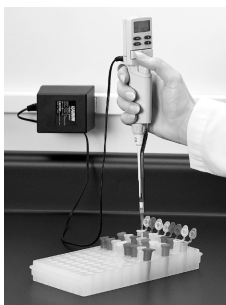

EDP3 Plus can be used while charging

### **FIGURE 5 CHARGING DEVICES:**

E3-WPS Wall Power Supply (left) and E3-RCS Rapid Charge Stand (right)

## **Battery Charging: Rapid Charge Stand**

---

E3-RCS Rapid Charge Stand will charge three EDP3-Plus pipettes, one at a time, in sequence. Charging contacts are located under the pipette “head” and shown in the diagram in Figure 6.

With only one EDP3-Plus on the stand, charging will proceed as if the wall power supply were connected directly to the pipette. However, when charging more than one EDP3-Plus, the first one placed on the stand will be charged first.

To charge a particular pipette, remove other pipettes and place the desired pipette in the stand.

It is a good idea to store the EDP3-Plus pipette on the stand when it is not in use. This practice will provide a safe storage place, and the EDP3-Plus will always be fully charged.

Note: no charging takes place if the EDP3-Plus pipette is above approximately 90% of its charging capacity, when connected to a charger. When charging is complete, the outer box on the “battery” symbol flashes once per second to show trickle charging is taking place. When the battery symbol flashes at a slow rate, dimming briefly every few seconds, charging is complete.

## Replacing the Battery

**ALL USER SETTINGS WILL BE LOST IF YOU REMOVE THE BATTERY.**  
To preserve your settings, plug in the optional wall power supply cord before removing the battery.

Open the battery compartment by pressing upward with the thumb on the grooved area of the compartment door.

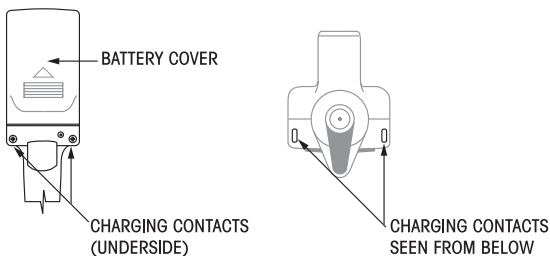

**FIGURE 6 BATTERY COMPARTMENT AND CHARGING CONTACTS**

1. Remove the old battery by lifting the unattached end slightly and sliding it out.
2. Align the replacement battery connector plug with the socket



in the battery compartment. Slide the battery into place. You will see all the display segments turn on at once, then the display shows "PL" and the software version. Then you will hear EDP3-Plus set itself to zero after a few seconds.

3. Replace the battery compartment door.

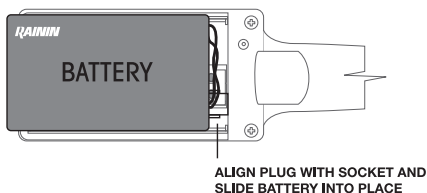

**FIGURE 7 REPLACING THE BATTERY**

Battery life is dependent on such factors as:

- Pipette volume range
- Full-range or part-range pipetting
- Multidispensing

## Tip Ejector Arm Removal

The tip ejector can be removed if necessary. Three types of tip ejector are used and all can be removed with minimum effort—do not use force.

Up to 2000  $\mu\text{L}$  models, press the quick-release tabs on the ejector arm and pull the ejector down. For 5000  $\mu\text{L}$  & 10 mL, grasp the top of the ejector arm and pull outward then downward. For 20 mL, pull the lower part of the tip ejector away from the upper part (do not remove the upper part).

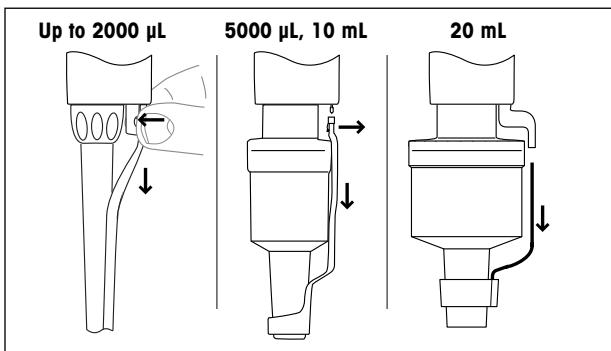

**FIGURE 8 REMOVING THE TIP EJECTOR ARM**

To replace the ejector arm on all models except 20 mL, insert the shaft through the large opening, align the top with the tip ejector pushrod, and push until the ejector arm snaps in place. For 20 mL, place the large opening over the shaft and align the rod in the lower part of the tip ejector with the hole in the upper part and press firmly.

## Care and Maintenance

EDP3-Plus pipettes are sophisticated lab instruments and should be treated with appropriate care. Your EDP3-Plus should give years of trouble-free service provided it is treated with proper care and the operating recommendations in this manual are followed.

The most important factor in taking proper care of the EDP3-Plus pipette is to keep the mechanism dry and clean. The following simple rules should be strictly observed.

1. Never allow liquid to enter the shaft where it can contact the piston or seal.
2. Never pick up liquid without a tip attached.
3. Never invert the EDP3-Plus pipette or lay it on its side with liquid in the tip. Always hold it upright and store it upright if possible. The Rapid Charge Stand can be used to hold (and charge) three EDP3-Plus pipettes.
4. Never use solvents to clean EDP3-Plus. Instead, use a lint-free wipe dampened with water to clean the instrument. Keep the keyboard display dry.
5. Never attempt to recharge EDP3-Plus with any other device than either the RAININ Model E3-WPS Wall Power Supply or the Model E3-RCS Rapid Charge Stand. Severe damage to the internal electronics would result.



## Autoclaving

---

Autoclavable parts of EDP3-Plus are the shaft and the tip ejector: 121°C, 1 bar, 15-20 minutes.

**Do not autoclave the complete EDP3-Plus pipette or any parts other than the shaft and tip ejector.**

## Troubleshooting and Repairs

---

**Warning:** On models from 10–200  $\mu\text{L}$ , when removing the shaft from the body, ensure the spring, seal and o-ring do not fall off the piston.

### Sample Splash (liquid inside the mechanism)

1. Refer to Figure 8 to remove the tip ejector arm.
2. Unscrew the shaft coupling and carefully remove the shaft. Note how the parts fit onto the piston.
3. Inspect the seal assembly and piston for contamination. The piston should be shiny and free of corrosion. Clean with distilled water or isopropyl alcohol. Dry with a lint-free tissue and reassemble after inspecting the interior of the shaft for any contamination.
4. If piston corrosion or staining is evident, do not use the pipette. Call 800-662-7027 for Pipette Service.

### Leaks, Inaccurate Sampling, Abnormal Stroke

1. **Loose shaft.** Tighten coupling by hand.
2. **Split or cracked shaft.** Remove the tip ejector and inspect the shaft. Replace the shaft if necessary. If the shaft was dropped, remove it to see if the piston is bent. If so, return the instrument for service.
3. **Worn seal and/or o-ring.** Models below 5000  $\mu\text{L}$  use a polyethylene seal and o-ring. Check the seal and o-ring, replacing them as necessary. To replace, pull off the old seal and o-ring, position the new seal and o-ring on the piston assembly, and reassemble the pipette.

**Do not lubricate any components\*.** EDP3-Plus has a dry seal (\*except for 5000  $\mu\text{L}$ , 10 mL, and 20 mL models, which use a small amount of grease on the seal).

After pipetting concentrated acids or highly corrosive solutions, disassemble EDP3-Plus and inspect and clean the piston assembly, shaft, and seal with distilled water. Dry all components thoroughly and reassemble.

Extensive contact with corrosive fumes may result in premature seal wear and damage to the piston. Exposure of internal components to corrosive fumes can be reduced by using RAININ tips with aerosol barrier filters.

## **Service, Calibration and Repair**

---

**RAININ** Pipette Repair and Calibration facilities:

**California:**

7500 Edgewater Drive, Oakland CA 94621  
Tel. 800-662-7027, Fax 510-564-1683  
5955 Mira Mesa Blvd, Ste B, San Diego, CA 92121  
Tel. 800-662-7027, Fax 858-320-0556

**Massachusetts:** Rainin Road, Woburn, MA 01801

Tel. 800-662-7027, Fax 781-935-7631

**Japan:** 4-1-11, Bunkyo-Ku, Tokyo 113-0033

Tel. (03) 5689-8311, Fax (03) 5689-2670

**METTLER TOLEDO** Pipette Repair and Calibration facilities:

**Belgium:** N.V. Mettler-Toledo s.a., B-1932 Zaventem

Tel. (02) 334 02 11, Fax (02) 334 03 34

**Germany:** Mettler-Toledo GmbH, D-35353 Giessen

Tel. (0641) 50 70, Fax (0641) 507 128

**Denmark:** Mettler-Toledo A/S, DK-2600 Glostrup

Tel. (43) 270 800, Fax (43) 270 828

**Spain:** Mettler-Toledo S.A.E., E-08038 Barcelona

Tel. (93) 223 76 00, Fax (93) 223 02 71

**France:** HTS – F28000 Chartres

Tel. (02) 37 88 31 00, Fax (02) 37 88 31 09

**Italy:** Mettler-Toledo S.p.A., I-20026 Novate Milanese

Tel. (02) 333 321, Fax (02) 356 29 73

**Netherlands:** Mettler-Toledo B.V., NL-4004 JK Tiel

Tel. (0344) 63 83 63, Fax (0344) 63 83 90

**Sweden:** Mettler-Toledo AB, S-12008 Stockholm

Tel. (08) 702 50 00, Fax (08) 642 45 62

Service is also available in many other countries through authorized RAININ distributors. See [www.rainin-global.com](http://www.rainin-global.com).

It is recommended to use only genuine RAININ replacement parts such as seals and shafts. It is NOT necessary to recalibrate the pipette after changing the seal or shaft. Recalibration of the pipette is only necessary when the piston is replaced, and should be done only by qualified factory-trained personnel in one of the above-mentioned facilities.

For pipettes under warranty, please note that the warranty will be voided if the pipette has been damaged as a result of physical or chemical abuse, or if the pipette has been repaired or recalibrated by any service facility which is not authorized by Rainin.

Contact Technical Support at 800-543-4030 for further information.

## Replacement Parts

A Shaft E Stroke Spring	B Tip Ejector F Seal Retainer	C Seal G Shaft Coupling	D O-ring
----------------------------	----------------------------------	----------------------------	----------

### Parts for E3-Series 10 µL to 1000 µL:

E3-10	E3-20	E3-100	E3-200	E3-300	E3-1000
A 6202-064	6202-065	6202-066	6202-067	6202-425	6202-068
B 6202-071	6202-071	6202-073	6202-073	6200-419	6202-074
C 6200-138	6200-143	6200-150	6200-154	6200-415	6200-161
D 6200-139	6200-170	6200-151	6200-155	6200-414	6200-162
E 6200-195	6200-197	6200-197	6200-199	6200-199	6107-108
F 6200-196	6200-198	6200-201	6200-200	6200-416	6107-106
G 6107-063	6107-063	6107-063	6107-063	6107-063	6107-063

### Parts for SE3-Series 10 µl to 1000 µl:

SE3-10	SE3-20	SE3-100	SE3-200	SE3-300	SE3-1000
A 6200-140	6200-145	6200-147	6200-157	6200-413	6200-160
B 6200-133	6200-144	6200-148	6200-156	6200-419	6200-163
C 6200-138	6200-143	6200-150	6200-154	6200-415	6200-161
D 6200-139	6200-170	6200-151	6200-155	6200-414	6200-162
E 6200-195	6200-197	6200-197	6200-199	6200-199	6107-108
F 6200-196	6200-198	6200-201	6200-200	6200-416	6107-106
G 6107-063	6107-063	6107-063	6107-063	6107-063	6107-063

Note: 200µL & 1000µL models may have either regular-length or short shafts and tip ejectors. If you need a replacement shaft, refer to the length of the dismantled shaft shown below (A\*) for correct ordering: Short shaft and short tip ejector must be used together.

E3 Series (LTS)	200 µL	1000 µL
A* Short Shaft (200 = 94 mm, 1000 = 99 mm)	6202-229	6202-230
B Short Tip Ejector (use with A*, above)	6202-231	6202-232
SE3 Series (Traditonal)		
A* Short Shaft (200 = 94 mm, 1000 = 99 mm)	6200-382	6200-383
B Short Tip Ejector (use with A*, above)	6202-231	6202-232

### Parts for E3 and SE3 series 2000 µL to 10 mL:

A Piston O-ring E Tip Ejector	B Cylinder F Seal	C Cylinder O-ring G Stroke Spring	D Shaft H Seal Retainer
	2000 µL	5000 µL	10 mL
A	6200-167	6107-112	6107-113
B	n/a	6200-365	6200-371
C	n/a	6200-364	6200-370
D E3 Series	6202-214	6202-222	6202-223
D SE3 Series	6200-169	6200-362	6200-368
E	6200-168	6200-373	6200-374
F	6200-166	n/a	n/a
G	6107-109	n/a	n/a
H	6107-107	n/a	n/a

### Common parts for 5000 µL and 10 mL E3 and SE3 series:

Tube of grease:	6100-555
Filters: 6190-164 (pack of 100)	6190-165 (pack of 1000)

### Parts for E3-20ML:

Piston O-ring	6202-299	Cylinder	6202-301
Cylinder O-ring	6202-300	Shaft	6202-302
Tip Ejector	6202-298	Tube of grease:	6100-555
Filters: 6190-221 (pkg of 100)		6190-222 (pkg of 500)	

### Parts common to all EDP3-Plus models:

Battery:	6107-040
Battery Cover:	6107-230
Wall Power Supply, US	E3-WPS
Wall Power Supply, UniversalK	E3-WPSUNI

## Specifications

These manufacturer's specifications should be used as guidelines when establishing your own performance specification.

EDP3-Plus Specifications						
Model	Volume	Increment	Accuracy		Precision	
	$\mu\text{l}$		%	$\mu\text{l} (\pm)$	%	$\mu\text{l} (\leq)$
10 $\mu\text{l}$	1	0.01	2.5	0.025	1.2	0.012
	5		1.5	0.075	0.6	0.03
	10		1.0	0.1	0.4	0.04
20 $\mu\text{l}$	2	0.02	7.5	0.15	2.0	0.04
	10		1.5	0.15	0.5	0.05
	20		1.0	0.2	0.3	0.06
100 $\mu\text{l}$	10	0.1	3.5	0.35	1.0	0.1
	50		0.8	0.4	0.24	0.12
	100		0.8	0.8	0.15	0.15
200 $\mu\text{l}$	20	0.2	2.5	0.5	1.0	0.2
	100		0.8	0.8	0.25	0.25
	200		0.8	1.6	0.15	0.3
300 $\mu\text{l}$	30	0.2	2.5	0.75	1.0	0.3
	150		0.8	1.2	0.25	0.375
	300		0.8	2.4	0.15	0.45
1000 $\mu\text{l}$	100	1.0	3.0	3.0	0.6	0.6
	500		0.8	4.0	0.2	1.0
	1000		0.8	8.0	0.15	1.5
2000 $\mu\text{l}$	200	2.0	3.0	6.0	0.6	1.2
	1000		0.8	8.0	0.2	2.0
	2000		0.8	16.0	0.12	2.4
5000 $\mu\text{l}$	500	5.0	2.4	12.0	0.6	3.0
	2500		0.6	15.0	0.2	5.0
	5000		0.6	30.0	0.16	8.0
10 ml	1 ml	10.0	5.0	50.0	0.6	6.0
	5 ml		1.0	50.0	0.2	10.0
	10 ml		0.6	60.0	0.16	16.0
20 ml	2 ml	20.0	5.0	100.0	0.60	12.0
	10 ml		1.0	100.0	0.20	20.0
	20 ml		0.6	120.0	0.16	32.0

Specifications are subject to change without notice.

## Electrical specifications

This device is intended for use only with the power sources with RAININ part numbers listed below. No other power sources may be used with this device.

Wall Power Supply Input: P/N E3-WPS 120VAC 60 Hz  
P/N E3-WPSUNI 100-240VAC 50-60 Hz

Wall Power Supply Output: All P/Ns 5.5VDC 1.04 A Regulated Nominal  
Battery P/N 6107-040 Li-Ion 3.6 VDC Nominal  
400mAh Nominal

Explanation of symbols: A - Ampere, Hz - Hertz, mAh - Milliamp Hour,  
VAC - Volts Alternating Current, VDC - Volts Direct Current

## Appendix A GLP Modes

GLP mode is a special mode for viewing, tracking, and saving various usage log information, e.g. the number of pipetting cycles, or number of days in use. GLP mode could also be used to track non-service issues, such as the number of days a particular pipette is used for a particular lab task, and so on.

GLP mode is accessed through the MULTI mode. In MULTI mode, press and hold the MODE key to reach the options and hidden modes, click MODE until GLP is reached, then switch on GLP mode with the ARROW key. Press RESET and click MODE until GLP is reached.

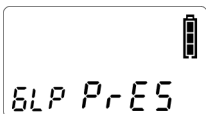

GLP mode is on, showing the Pres(ent) set of usage logs

GLP mode shows various usage logs for EDP3-Plus. The first level of GLP logs (without options) is reached by pressing RESET to cycle through these logs in turn, as shown below:

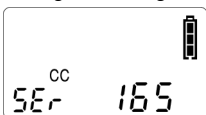

The cycle count since the last service entry (SEr). Press RESET

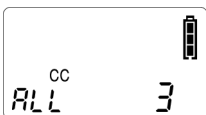

Total cycle count (ALL) of EDP3-Plus, in thousands  
Press RESET

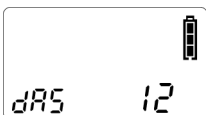

Number of days (dAS) since the last service entry

## GLP Options

OPTIONS AVAILABLE: AL — dAL — Add

GLP options are accessed from within the GLP mode by a long press of the MODE key. Cycle through each in turn by clicking MODE.

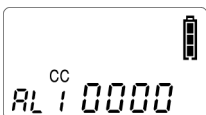

Cycle count alarm set to 10000 cycles. ARROW keys to set, in thousands, note that as the number gets into 10,000s, the significant unit moves to the left.  
(Silent alarm; announced on display)

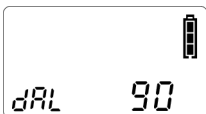

Day alarm (silent) set for 90 days. Use ARROW key to set from 1 to 999 days

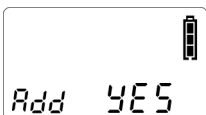

Add service entry. Use ARROW key to toggle between "Yes" or "No". If "Yes" is selected, click the trigger to begin making an entry

The next screens show a service entry being made. If "Add" was selected in the last screen, click the trigger to open the next screen to set the date, with the "month" number flashing.

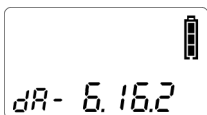

Use ARROW keys to select the month, move to the next field with the trigger key, then set the day and year the same way

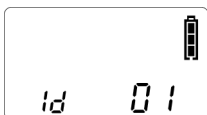

Finish the service entry by setting an ID value (01 to 99) with the up/down ARROW keys followed by pressing either trigger to complete the service entry

Making a service entry does two things: (a) The current (present) cc and date logs are saved with the date and technician ID, at the next lower menu level and (b) the current logs are zeroed and counting will start again when you start pipetting again. As you cycle through the modes, GLP mode show PrES: the present set of logs.

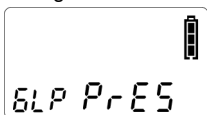

Press the DOWN ARROW at this screen to see the last-saved set of logs

Pressing the DOWN ARROW opens the last-saved set, level 1, which you can cycle through using RESET. Then the DOWN ARROW opens the next-last set at level 2, and so on to 40 levels. The UP ARROW takes you to more recent entries.

## Sample GLP Menu Logs

The following table is a representation of 6 sample sets of GLP logs. Each field of the table is displayed one at a time on the LCD. To navigate through the entries, use the RESET key to move to the "right", and the UP/DOWN ARROW keys to move "vertically".

At any point in the GLP logs, pressing and holding RESET takes you to the GLP PrES position.

Log Set #	Cycle count since last service	Cycle count total	Days since last service / service date	Tech ID
GLP PrES	SEr 320	ALL 12	dAS 2	n/a
GLP 1	SEr 2617	ALL 11	6.15.2	02
GLP 2	SEr 2524	ALL 9	4.15.2	02
GLP 3	SEr 2491	ALL 6	3.15.2	02
GLP 4	SEr 2605	ALL 4	2.15.2	02
GLP 5	SEr 1572	ALL 1	1.15.2	02

**EC Declaration of Conformity  
according to ISO/IEC Guide 22 and EN45014**

Manufacturer's Name: Rainin Instrument, LLC.

Manufacturer's Address: 7500 Edgewater Drive, Oakland, CA, 94621, USA

declares that the following product:

Product Name: EDP3-Plus Electronic Motorized Microliter Pipette

Model Number: EDP3-Plus

Product Options: E3-RCS Rapid Charge Stand  
E3-WPS Wall Power Supply

conforms to the following Product Specifications:

Safety: EN61010-1:1995  
IEC1010:1995 + A1, A2

EMC: EN61326 04:1997 (Emissions)  
EN55011:1998  
CIRSPR 11:1997  
(Class A Conducted Emissions and  
Radiated Emissions)  
EN61326 04:1997 (Immunity)  
EN61000-4-2:1995+ IEC6100-4-2,A1 1998-01  
(ESD Immunity)  
EN61000-4-3:1996  
(RF Immunity 80-100MHz)  
ENV50204:1996  
(RF Immunity 900 MHz)  
EN61000-4-4:1995  
(Electrical Fast Transient Immunity)  
EN61000-4-5:1995  
(Surge Immunity)  
EN61000-4-6:1996  
(Conducted Immunity)  
EN61000-4-11:1994-08

Supplementary Information:

Responsible Signatory: Jim Petrek, VP, R & D

Date: April 22, 2002

This Declaration of Conformity applies only to products which have the CE mark attached.

**WARNING:**

This equipment generates and uses radio frequency energy and if not installed and used properly, i.e. in strict accordance with the instruction manual, may cause harmful interference to radio communications. It has been tested and found to comply with the limits for a Class A computing device pursuant to Subpart J of Part 15 of FCC rules, which are designed to provide reasonable protection against such interference when operated in a commercial environment.

Operation of this equipment in a residential area is likely to cause interference, in which case the user at his own expense will be required to take whatever measures may be required to correct the interference.

### Limited Warranty

See the Limited Warranty and Limitations of Liability Statement. Please complete and return the Warranty Registration Card on receipt of your pipette.

RAININ pipettes are calibrated with RAININ tips. To assure excellent reproducibility and performance, use only RAININ tips as recommended in this manual. Specified performance is guaranteed only when RAININ tips are used.

## Contacting RAININ

### Technical Information:

T: 800-543-4030 F: 510-564-1617 tech.support@rainin.com

### Pipette Service:

T: 800-662-7027 F: 781-935-7631 service@rainin.com

### Direct Order Line:

T: 800-472-4646 F: 510-564-1617 pipets@rainin.com

RAININ website: [www.rainin.com](http://www.rainin.com)

From outside North America: T: +1-510-564-1600

[global@rainin.com](mailto:global@rainin.com) (from outside the U.S.)

### METTLER TOLEDO Offices

METTLER TOLEDO website: [www.mt.com/rainin](http://www.mt.com/rainin)

#### Mettler-Toledo (Schweiz) GmbH, Im Langacher , 8606 Greifensee CH

Verkauf 044 944 45 45 salesRN.ch@mt.com

Service 044 944 47 47 serviceRN.ch@mt.com

#### Mettler Toledo GmbH, Ockerweg 3 , 35396 Giessen DE

Verkauf +49 641 507 222 info.mtd@mt.com

Service +49 641 507 307 info.mtd@mt.com

#### Mettler-Toledo SAS, 18-20 avenue de la Pépinière , 78220 Viroflay FR

Ventes 01 30 97 17 17 marcom.fr@mt.com

Laboratoire d'Etalonnage Accrédité,

264 rue Abraham Lincoln Service Pipette, 62400 Bethune FR

Service 03 21 64 54 66 marcom.fr@mt.com

#### N.V. Mettler-Toledo S.A., Leuvensesteenweg 384 , 1932 Zaventem BE

Sales +32 2334 0211 general.mtb@mt.com

Service +32 2334 0211 general.mtb@mt.com

#### Mettler-Toledo S.A.E., Miguel Hernández 69-71 ,

#### 08908 L'Hospitalet de Llobregat (Barcelona) ES

Ventas 0034 93 223 7666 mtemkt@mt.com

Servicio Técnico 0034 93 223 7666 mtemkt@mt.com

#### Mettler-Toledo A/S, Naverland 8 , 2600 Glostrup DK

Salg 43 27 08 25 info.mtdk@mt.com

Service 43 27 08 25 info.mtdk@mt.com

Rainin Instrument, LLC  
7500 Edgewater Drive, Oakland, CA 94621-0060



a METTLER TOLEDO Company  
Prices and specifications are subject to change without notice.  
Copyright 1999-2008, Rainin Instrument, LLC.

9920-235 Rev J