

**Aqualog<sup>®</sup>**

**Operation Manual**  
**Part number J810012 rev. E**

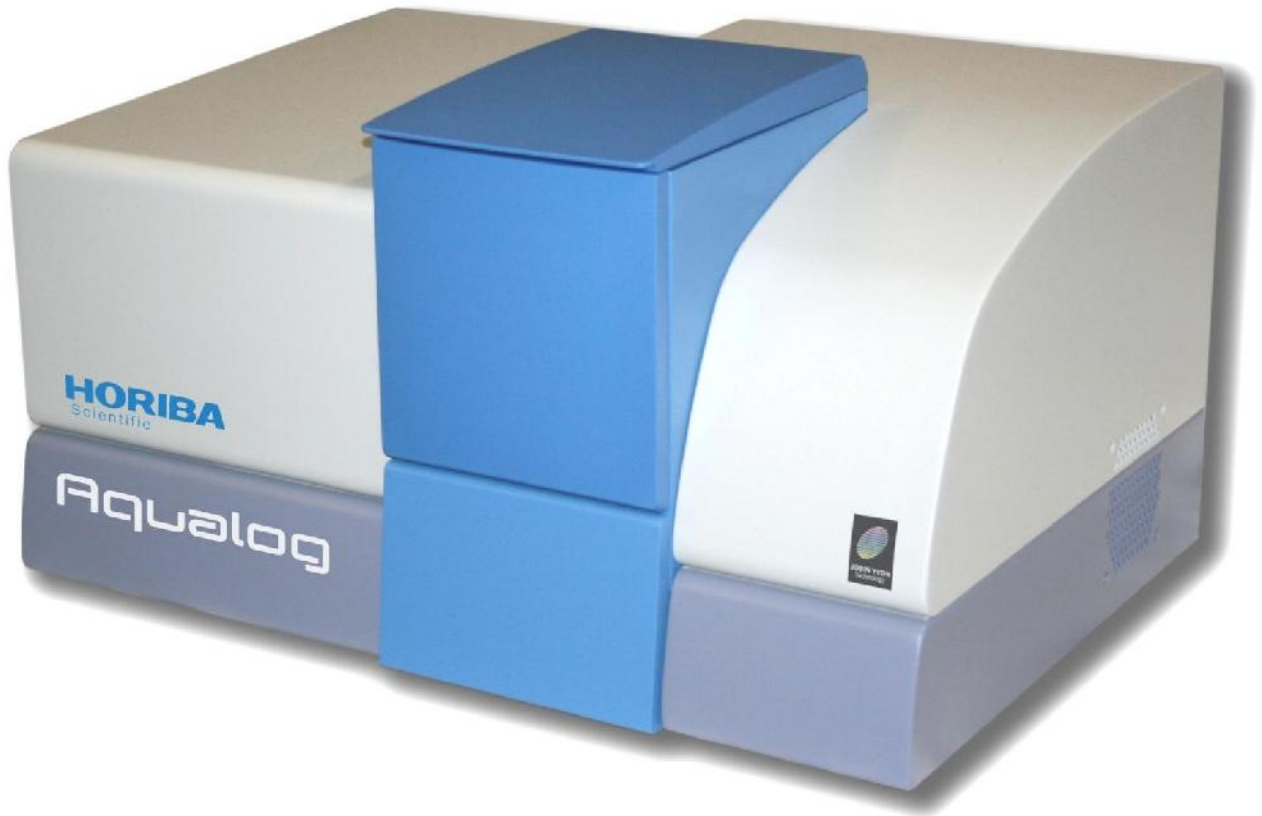

# Aqualog®



## Operation Manual

<http://www.HORIBA.com>

Rev. E



**HORIBA**  
Scientific

Copyright © 2011–2013 by HORIBA Instruments Incorporated. All rights reserved. No part of this work may be reproduced, stored, in a retrieval system, or transmitted in any form by any means, including electronic or mechanical, photocopying and recording, without prior written permission from HORIBA Instruments Incorporated. Requests for permission should be requested in writing. Origin<sup>®</sup> is a registered trademark of OriginLab Corporation. Alconox<sup>®</sup> is a registered trademark of Alconox, Inc. Ludox<sup>®</sup> is a registered trademark of W.R. Grace and Co. Teflon<sup>®</sup> is a registered trademark of E.I. du Pont de Nemours and Company. Windows<sup>®</sup> is a trademark of Microsoft Corporation. MATLAB<sup>®</sup> is a registered trademark of The Mathworks, Inc.

Information in this manual is subject to change without notice, and does not represent a commitment on the part of the vendor.

October 2013

Part Number J810012



# Table of Contents

<b>0: Introduction</b> .....	<b>0-1</b>
About the Aqualog® .....	0-1
Chapter overview .....	0-2
Disclaimer.....	0-3
Safety summary .....	0-5
Risks of ultraviolet exposure .....	0-8
Additional risks of xenon lamps.....	0-10
CE compliance statement .....	0-12
RoHS Declaration of Conformity.....	0-13
Waste Electrical and Electronic Equipment (WEEE) .....	0-14
<b>1: Spectroscopy and the Aqualog®</b> .....	<b>1-1</b>
Introduction.....	1-1
Overview of analysis of samples including CDOM .....	1-2
Flowchart for typical Aqualog® EEM experiments for CDOM .....	1-6
<b>2: Requirements &amp; Installation</b> .....	<b>2-1</b>
Safety-training requirements .....	2-1
Surface requirements.....	2-2
Environmental requirements .....	2-3
Electrical requirements.....	2-4
Unpacking and Installation .....	2-5
Software emulation .....	2-9
<b>3: System Description</b> .....	<b>3-1</b>
Introduction.....	3-1
Basic theory of operation .....	3-1
Optical layout.....	3-3
<b>4: System Operation</b> .....	<b>4-1</b>
Introduction.....	4-1
Power switch .....	4-1
Turning on the system.....	4-2
Validating system performance.....	4-3
<b>5: Data-Acquisition</b> .....	<b>5-1</b>
Introduction to Aqualog® software .....	5-1
Experiment Menu button .....	5-2
Previous Experiment Menu button .....	5-6
Auto Run Previous Experiment button.....	5-8
Aqualog IFE button .....	5-9
Rayleigh Masking button .....	5-10
Normalize button .....	5-12
Run JY Batch Experiments button .....	5-14
Switch menu between HJY Software Application and Origin Pro button.....	5-16
Quinine Sulfate Units button .....	5-17
Profile Tool button .....	5-19
Rescale Y button .....	5-21
Automatic sample queuing.....	5-22
Raman Scattering Area Unit button .....	5-37
<b>6: Various Experiment Types</b> .....	<b>6-1</b>
Introduction.....	6-1
Absorbance spectra .....	6-2
Two-dimensional emission spectra .....	6-6
Three-dimensional emission spectra .....	6-9
Kinetics spectra .....	6-18
Single-point spectra .....	6-21

Running an unknown sample.....	6-25
<b>7: Troubleshooting.....</b>	<b>7-1</b>
Troubleshooting table.....	7-1
Further assistance.....	7-4
<b>8: Modeling with Solo.....</b>	<b>8-1</b>
Introduction.....	8-1
Using PARAFAC.....	8-2
Using Principal-Component Analysis.....	8-16
Using classical least-squares fitting.....	8-21
Perform Split-Half Analysis button.....	8-28
<b>9: Optimizing Data.....</b>	<b>9-1</b>
Cuvette preparation.....	9-1
Sample preparation.....	9-2
Running a scan on a sample.....	9-4
Improving the signal-to-noise ratio.....	9-5
Sources for instrument noise.....	9-9
Optimizing Raman and QSU standards.....	9-10
Suggestions for best use of the Aqualog®.....	9-11
<b>10: Maintenance.....</b>	<b>10-1</b>
Introduction.....	10-1
Lamp replacement.....	10-1
Changing the charcoal filters on the Aqualog®-UV.....	10-21
<b>11: Components &amp; Accessories.....</b>	<b>11-1</b>
Itemized list of Aqualog® accessories.....	11-2
FL-1013 Liquid Nitrogen Dewar Assembly.....	11-3
Sample cells.....	11-4
F4-3000 Fiber Optic Mount and 1950 Fiber Optic Bundles.....	11-5
FL4-1011 Four-Position Thermostatted Cell Holder.....	11-6
FL4-1012 Dual-Position Thermostatted Cell Holder.....	11-8
FL4-1027 Single-Position Thermostatted Cell Holder.....	11-10
J1933 Solid Sample Holder.....	11-12
1905-OFR 150-W Xenon Lamp.....	11-14
FL4-1015 Injector Port.....	11-15
F-3030 Temperature Bath.....	11-16
<b>12: Technical Specifications.....</b>	<b>12-1</b>
Introduction.....	12-1
Spectrofluorometer system.....	12-2
Minimum host-computer requirements.....	12-4
Software.....	12-4
<b>13: Glossary.....</b>	<b>13-1</b>
<b>14: Bibliography.....</b>	<b>14-1</b>
<b>15: Compliance Information.....</b>	<b>15-1</b>
Declaration of Conformity.....	15-1
Supplementary Information.....	15-1
<b>16: Index.....</b>	<b>16-1</b>

# 0: Introduction

## About the Aqualog<sup>®</sup>

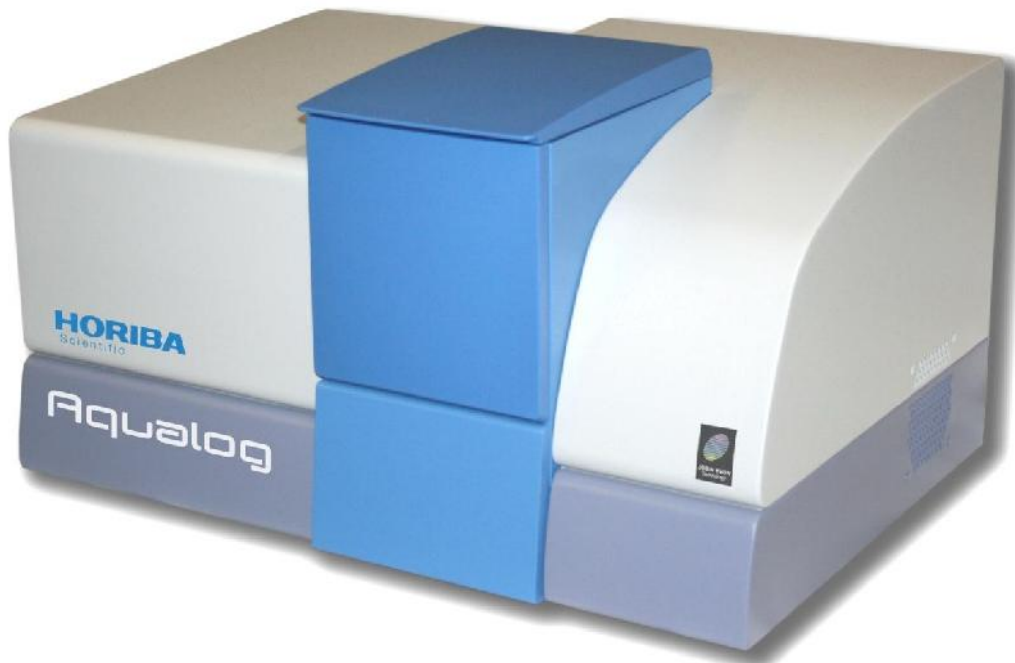

The Aqualog<sup>®</sup> is a self-contained, fully automated spectrofluorometer system. Data output is viewed on a PC, while printouts may be obtained via an optional plotter or printer. All Aqualog<sup>®</sup> functions are under the control of Aqualog<sup>®</sup> spectroscopy software. The main parts of the Aqualog<sup>®</sup> spectrofluorometer systems are:

- State-of-the-art optical components
- A personal computer
- Aqualog<sup>®</sup> for Windows<sup>®</sup>, the driving software.

This manual explains how to operate and maintain an Aqualog<sup>®</sup> spectrofluorometer. The manual also describes measurements and tests essential to obtain accurate data. For a complete discussion of Aqualog<sup>®</sup> software<sup>®</sup>, refer to the *Aqualog<sup>®</sup> User's Guide* (especially regarding software installation) and the on-line help for Origin<sup>®</sup>, which accompany the system.



**Note:** Keep this and the other reference manuals near the system.

# Chapter overview

<b>0: Introduction</b>	Describes safety, RoHS, and WEEE information.
<b>1: Spectroscopy and the Aqualog®</b>	Introduction to fluorescence and absorption spectroscopy, as well as kinetic analysis, using the Aqualog®.
<b>2: Requirements &amp; Installation</b>	Power and environmental requirements; select the best spot for the instrument.
<b>3: System Description</b>	How the Aqualog® works.
<b>4: System Operation</b>	Operation of the spectrofluorometer system, and calibration instructions.
<b>5: Data-Acquisition</b>	How to use the special Aqualog® software buttons to acquire and plot data; how to determine peaks in an unknown sample.
<b>6: Various Experiment Types</b>	Different types of experiments that the Aqualog® can perform.
<b>7: Troubleshooting</b>	How to handle problems that may occur occasionally.
<b>8: Modeling with Solo</b>	Describes several different modeling routines (PARAFAC, PCA, and CLS) included with the Solo software package.
<b>9: Data-Optimization</b>	Hints for improving the signal-to-noise ratio, instructions for obtaining corrected data, and other information useful for optimizing data and ensuring reproducibility.
<b>10: Maintenance</b>	Routine maintenance procedures such as replacing the lamp.
<b>11: Components &amp; Accessories</b>	Accessories available for the Aqualog®, and how to use them.
<b>12: Technical Specifications</b>	Instrument specifications and computer requirements.
<b>13: Glossary</b>	Some useful technical terms related to fluorescence and absorption spectroscopy.
<b>14: Bibliography</b>	Other important sources of information.
<b>15: CE Compliance Information</b>	CE Declaration of Conformity
<b>16: Index</b>	

# Disclaimer

By setting up or starting to use any HORIBA Instruments Incorporated product, you are accepting the following terms:

You are responsible for understanding the information contained in this document. You should not rely on this information as absolute or all-encompassing; there may be local issues (in your environment) not addressed in this document that you may need to address, and there may be issues or procedures discussed that may not apply to your situation.

If you do not follow the instructions or procedures contained in this document, you are responsible for yourself and your actions and all resulting consequences. If you rely on the information contained in this document, you are responsible for:

- Adhering to safety procedures
- Following all precautions
- Referring to additional safety documentation, such as Material Safety Data Sheets (MSDS), when advised

As a condition of purchase, you agree to use safe operating procedures in the use of all products supplied by HORIBA Instruments Incorporated, including those specified in the MSDS provided with any chemicals and all warning and cautionary notices, and to use all safety devices and guards when operating equipment. You agree to indemnify and hold HORIBA Instruments Incorporated harmless from any liability or obligation arising from your use or misuse of any such products, including, without limitation, to persons injured directly or indirectly in connection with your use or operation of the products. The foregoing indemnification shall in no event be deemed to have expanded HORIBA Instruments Incorporated's liability for the products.

HORIBA Instruments Incorporated products are not intended for any general cosmetic, drug, food, or household application, but may be used for analytical measurements or research in these fields. A condition of HORIBA Instruments Incorporated's acceptance of a purchase order is that only qualified individuals, trained and familiar with procedures suitable for the products ordered, will handle them. Training and maintenance procedures may be purchased from HORIBA Instruments Incorporated at an additional cost. HORIBA Instruments Incorporated cannot be held responsible for actions your employer or contractor may take without proper training.

Due to HORIBA Instruments Incorporated's efforts to continuously improve our products, all specifications, dimensions, internal workings, and operating procedures are subject to change without notice. All specifications and measurements are approximate, based on a standard configuration; results may vary with the application and environment. Any software manufactured by HORIBA Instruments Incorporated is also under constant development and subject to change without notice.

Any warranties and remedies with respect to our products are limited to those provided in writing as to a particular product. In no event shall HORIBA Instruments Incorporated

rated be held liable for any special, incidental, indirect or consequential damages of any kind, or any damages whatsoever resulting from loss of use, loss of data, or loss of profits, arising out of or in connection with our products or the use or possession thereof. HORIBA Instruments Incorporated is also in no event liable for damages on any theory of liability arising out of, or in connection with, the use or performance of our hardware or software, regardless of whether you have been advised of the possibility of damage.

# Safety summary

The following general safety precautions must be observed during all phases of operation of this instrument. Failure to comply with these precautions or with specific warnings elsewhere in this manual violates safety standards of design, manufacture and intended use of instrument. HORIBA Instruments Incorporated assumes no liability for the customer's failure to comply with these requirements. Certain symbols are used throughout the text for special conditions when operating the instruments:



A WARNING notice denotes a hazard. It calls attention to an operating procedure, practice, or similar that, if incorrectly performed or adhered to, could result in personal injury or death. Do not proceed beyond a WARNING notice until the indicated conditions are fully understood and met. HORIBA Instruments Incorporated is not responsible for damage arising out of improper use of the equipment.

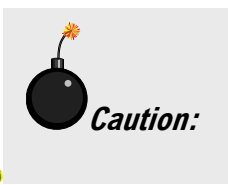

A CAUTION notice denotes a hazard. It calls attention to an operating procedure, practice, or similar that, if incorrectly performed or adhered to, could result in damage to the product. Do not proceed beyond a CAUTION notice until the indicated conditions are fully understood and met. HORIBA Instruments Incorporated is not responsible for damage arising out of improper use of the equipment.



Ultraviolet light! Wear protective goggles, full-face shield, skin-protection clothing, and UV-blocking gloves. Do not stare into light.



Intense ultraviolet, visible, or infrared light! Wear light-protective goggles, full-face shield, skin-protection clothing, and light-blocking gloves. Do not stare into light.



Extreme cold! Cryogenic materials must always be handled with care. Wear protective goggles, full-face shield, skin-protection clothing, and insulated gloves.

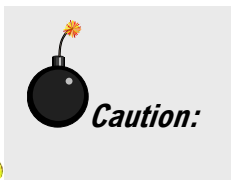

Explosion hazard! Wear explosion-proof goggles, full-face shield, skin-protection clothing, and protective gloves.



Risk of electric shock! This symbol warns the user that un-insulated voltage within the unit may have sufficient magnitude to cause electric shock.



Danger to fingers! This symbol warns the user that the equipment is heavy, and can crush or injure the hand if precautions are not taken.



This symbol cautions the user that excessive humidity, if present, can damage certain equipment.



Hot! This symbol warns the user that hot equipment may be present, and could create a risk of fire or burns.



Read this manual before using or servicing the instrument.



Wear protective gloves.



Wear appropriate safety goggles to protect the eyes.





Wear an appropriate face-shield to protect the face.

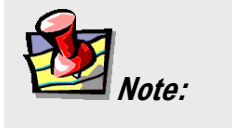

General information is given concerning operation of the equipment.

# Risks of ultraviolet exposure



**Caution:** This instrument is used in conjunction with ultraviolet light. Exposure to these radiations, even reflected or diffused, can result in serious, and sometimes irreversible, eye and skin injuries.

Overexposure to ultraviolet rays threatens human health by causing:

- Immediate painful sunburn
- Skin cancer
- Eye damage
- Immune-system suppression
- Premature aging

Do not aim the UV light at anyone.

Do not look directly into the light.

Always wear protective goggles, full-face shield and skin protection clothing and gloves when using the light source.

- Light is subdivided into visible light, ranging from 400 nm (violet) to 700 nm (red); longer infrared, “above red” or  $> 700\text{nm}$ , also called heat; and shorter ultraviolet radiation (UVR), “below violet” or  $< 400\text{nm}$ . UVR is further subdivided into UV-A or near-UV (320–400 nm), also called black (invisible) light; UV-B or mid-UV (290–320 nm), which is more skin penetrating; and UV-C or far-UV ( $< 290\text{ nm}$ ).
- Health effects of exposure to UV light are familiar to anyone who has had sunburn. However, the UV light level around some UV equipment greatly exceeds the level found in nature. Acute (short-term) effects include redness or ulceration of the skin. At high levels of exposure, these burns can be serious. For chronic exposures, there is also a cumulative risk of harm. This risk depends upon the amount of exposure during your lifetime. The long-term risks for large cumulative exposure include premature aging of the skin, wrinkles and, most seriously, skin cancer and cataract.
- Damage to vision is likely following exposure to high-intensity UV radiation. In adults, more than 99% of UV radiation is absorbed by the anterior structures of the eye. UVR can contribute to the development of age-related cataract, pterygium, photodermatitis, and cancer of the skin around the eye. It may also contribute to age-related macular degeneration. Like the skin, the covering of the eye or the cornea, is epithelial tissue. The danger to the eye is enhanced by the fact that light can enter from all angles around the eye and not only in the direction of vision. This is especially true while working in a dark environment, as the pupil is wide open. The lens can also be damaged, but because the cornea acts as a filter, the chances are re-

duced. This should not lessen the concern over lens damage however, because cataracts are the direct result of lens damage.

Burns to the eyes are usually more painful and serious than a burn to the skin. Make sure your eye protection is appropriate for this work. **NORMAL EYEGLASSES OR CONTACTS OFFER VERY LIMITED PROTECTION!**



**Caution:** *UV exposures are not immediately felt. The user may not realize the hazard until it is too late and the damage is done.*

## Training

For the use of UV sources, new users must be trained by another member of the laboratory who, in the opinion of the member of staff in charge of the department, is sufficiently competent to give instruction on the correct procedure. Newly trained users should be overseen for some time by a competent person.

# Additional risks of xenon lamps



Among the dangers associated with xenon lamps are:

- Burns caused by contact with a hot xenon lamp.
- Fire ignited by hot xenon lamp.
- Interaction of other nearby chemicals with intense ultraviolet, visible, or infrared radiation.
- Damage caused to apparatus placed close to the xenon lamp.
- Explosion or mechanical failure of the xenon lamp.



**Warning:** Xenon lamps are dangerous. Please read the following precautions.

## Visible radiation

Any very bright visible light source will cause a human aversion response: we either blink or turn our head away. Although we may see a retinal afterimage (which can last for several minutes), the aversion response time (about 0.25 seconds) normally protects our vision. This aversion response should be trusted and obeyed. **NEVER STARE AT ANY BRIGHT LIGHT-SOURCE FOR AN EXTENDED PERIOD.** Overriding the aversion response by forcing yourself to look at a bright light-source may result in permanent injury to the retina. This type of injury can occur during a single prolonged exposure. Excessive exposure to visible light can result in skin and eye damage.

Visible light sources that are not bright enough to cause retinal burns are not necessarily safe to view for an extended period. In fact, any sufficiently bright visible light source viewed for an extended period will eventually cause degradation of both night and color vision. Appropriate protective filters are needed for any light source that causes viewing discomfort when viewed for an extended period of time. For these reasons, prolonged viewing of bright light sources should be limited by the use of appropriate filters.

The blue-light wavelengths (400–500 nm) present a unique hazard to the retina by causing photochemical effects similar to those found in UV-radiation exposure.

## Infrared radiation

Infrared (or heat) radiation is defined as having a wavelength between 780 nm and 1 mm. Specific biological effectiveness “bands” have been defined by the CIE (Commission Internationale de l’Éclairage or International Commission on Illumination) as follows:

- IR-A (near IR) (780–1400 nm)
- IR-B (mid IR) (1400–3000 nm)
- IR-C (far IR) (3000 nm–1 mm)

The skin and eyes absorb infrared radiation (IR) as heat. Workers normally notice excessive exposure through heat sensation and pain. Infrared radiation in the IR-A that enters the human eye will reach (and can be focused upon) the sensitive cells of the retina. For high irradiance sources in the IR-A, the retina is the part of the eye that is at risk. For sources in the IR-B and IR-C, both the skin and the cornea may be at risk from “flash burns.” In addition, the heat deposited in the cornea may be conducted to the lens of the eye. This heating of the lens is believed to be the cause of so called “glassblowers’ ” cataracts because the heat transfer may cause clouding of the lens.

- Retinal IR Hazards (780 to 1400 nm): possible retinal lesions from acute high irradiance exposures to small dimension sources.
- Lens IR Hazards (1400 to 1900 nm): possible cataract induction from chronic lower irradiance exposures.
- Corneal IR Hazards (1900 nm to 1 mm): possible flashburns from acute high irradiance exposures.

Who is likely to be injured? The user and anyone exposed to the radiation or xenon lamp shards as a result of faulty procedures. Injuries may be slight to severe.

# CE compliance statement

The Aqualog<sup>®</sup> spectrofluorometer is tested for compliance with both the EMC Directive 2004/108/EEC and the Low Voltage Directive for Safety 2006/95/EEC, and bears the international CE mark as indication of this compliance. HORIBA Instruments Incorporated guarantees the product line's CE compliance only when original HORIBA Instruments Incorporated supplied parts are used. Chapter 14 herein provides a table of all CE Compliance tests and standards used to qualify this product.

# RoHS Declaration of Conformity

Manufacturer:     HORIBA Instruments Incorporated

Address:           3880 Park Avenue, Edison, NJ 08520, USA

Products:          Aqualog and Aqualog-UV spectrometers

HORIBA Instruments Incorporated certifies that the above Aqualog and Aqualog-UV models meet the requirements of DIRECTIVE 2002/95/EC, Restriction of Hazardous Substances Directive (RoHS). HORIBA Instruments Incorporated certifies that these Aqualog and Aqualog-UV models contain less than the following amounts of the six RoHS banned substances with the exemption stated in Note 2 below:

Substance	Threshold Level
Lead...Pb	Less than 0.1% <sup>1&amp;2</sup>
Mercury...Hg	Less than 0.1% <sup>1</sup>
Hexavalent Chromium...Cr(VI)	Less than 0.1% <sup>1</sup>
Polybrominated Biphenyls...PBB	Less than 0.1% <sup>1</sup>
Polybrominated Diphenyl Ethers...PBDE	Less than 0.1% <sup>1</sup>
Cadmium...Cd	Less than 0.01% <sup>1</sup>
Notes:	
1. Tolerated maximum concentration value by weight in homogeneous materials.	
2. Exemptions—Lead as an alloying element in steel containing up to 0.35% lead by weight, aluminum containing up to 0.4% lead by weight and as a copper alloy containing up to 4% lead by weight.	

Manufacturer's Authorized Representative:

\_\_\_\_\_ Date:  
 Ishai Nir  
 Director of Fluorescence Division

# Waste Electrical and Electronic Equipment (WEEE)

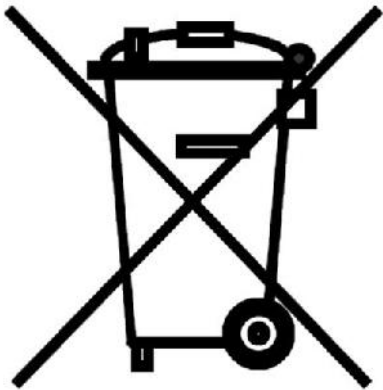

## WEEE Directive Symbol

This symbol on the product or its packaging indicates that this product must not be disposed of with regular waste. Instead, it is the user's responsibility to dispose of waste equipment according to local laws. The separate collection and recycling of the waste equipment at the time of disposal will help to conserve natural resources and ensure that it is recycled in a manner that protects human health and the environment. For information about where the user can drop off the waste equipment for recycling, please contact your local HORIBA Scientific representative.



# 1 : Spectroscopy and the Aqualog®

## Introduction

The Aqualog® spectrometer combines both fluorescence and absorbance measurements simultaneously with matching optical bandpass resolution. Simultaneous acquisition can be very important for accurate spectral analysis of colored dissolved organic matter (CDOM) in water samples associated with water-quality studies.

The main advantages the Aqualog® provides for simultaneous fluorescence and absorbance analysis of CDOM include:

- Absorbance spectral information can be used to immediately correct the fluorescence spectrum for the inner-filter-effects (IFE) involving both the excitation light-absorption and fluorescence reabsorption in the sample cuvette;
- Simultaneous acquisition under the same bandpass resolution eases true matching of spectral features required for accurate inner-filter-effect correction;
- Simultaneous measurement allows monitoring of photobleaching of the CDOM materials, which are very sensitive to UV wavelengths of the exciting light used to measure the absorbance and excite fluorescence;
- Excitation and absorbance wavelengths are scanned from low-energy to high-energy (red to UV) to reduce the exposure of the sample to UV and hence photobleaching;
- Absorbance data provide additional—and often vital—concentration-dependent information on non-fluorescent compounds in the water sample;
- IFE correction often greatly reduces analysis and sample-preparation time, and increases accuracy by eliminating error-prone dilution procedures and their record-keeping.

# Overview of analysis of samples including CDOM

## Introduction to EEMs for CDOM

Given the complex multitude of CDOM components in many bodies of water, a rapid method for qualitative and quantitative determinations has obvious value to the water-quality research and analysis community. The most conventional method of analyzing CDOM using fluorescence is the excitation-emission map (EEM). EEMs are recorded by scanning the excitation spectrum (or absorbance) of the fluorescent sample's components at the same time as the fluorescence-emission spectrum is recorded, for each excitation wavelength. This results in a "three-dimensional" intensity map of the sample's fluorescence, showing both the emission and absorbance spectra of all fluorescent components in the measured wavelength region. The EEM, however, does not contain the absorbance spectral information of non-fluorescent components in the sample. Moreover, the EEM spectral information can be distorted by inner-filter effects associated with absorbance of the excitation beam and fluorescence. So it follows that ideally the EEM should be measured *along with* the absorbance spectrum of the sample to ease inner-filter effect correction and monitoring bleaching of the sample, as well as to provide information about non-fluorescent compounds absorbing light in the sample.

## Spectral correction: Wavelength-dependent detector response

Because most CDOM studies rely on comparison to traceable spectral and concentration standard samples, the spectral-correction of the EEM is of prime concern. A typical EEM scans the sample across the excitation wavelengths from about 200–800 nm (depending on the Aqualog<sup>®</sup> model), and across the emission wavelengths from 250–800 nm (depending on the Aqualog<sup>®</sup> model). Bandpass and resolution are typically (and fixed in the Aqualog<sup>®</sup> to) 5 nm. To account for variations in the excitation beam's intensity, a reference detector,  $R$ , collects a small fraction of the excitation beam, and the emission detector's output,  $S$ , is ratioed to the reference detector signal ( $S/R$ ).

However, the instrument's optical responsivity is not ideal throughout the wavelength-range of the experiment, so a series of instrumental spectral correction-factors must be used to obtain reproducible ideal spectra that are traceable to established, calibrated spectral standard samples, detectors, and light sources.

- Dark-current signals must be subtracted, respectively, from both the  $S$  and  $R$  detector signals.
- The  $S$  and  $R$  detectors' signals must also be respectively multiplied by the excitation ( $X_{\text{correct}}$ ) and emission ( $M_{\text{correct}}$ ) spectral correction factors.

It follows that the final signal plotted as a function of wavelength in an EEM involves both the corrected reference signal,  $R_c$ ,

$$R_c = (R - \text{dark}) \cdot X_{\text{correct}}$$

and the corrected emission-detector signal,  $S_c$ ,

$$S_c = (S - \text{dark}) \cdot M_{\text{correct}}$$

The final fluorescence signal recorded is thus  $S_c/R_c$  for both the sample to be evaluated and for a representative reference or blank sample as discussed below.

Simultaneous to the EEM, the sample's spectral transmittance and absorbance properties can be recorded with the Aqualog<sup>®</sup>. From the Beer-Lambert law, absorbance defined as  $Abs = \epsilon cl$ , where  $\epsilon$  is the extinction coefficient,  $c$  is the concentration and  $l$  is the pathlength of the sample cell. Within the Aqualog<sup>®</sup>, the transmission detector signal,  $A_c = A - \text{dark}$  signal, is used to calculate the  $Abs$  and transmittance ( $T$ ) values. The transmission detector's signal,  $A_c$ , is also corrected for the excitation-source intensity measured using the reference detector signal ( $R_c$ ) formulated above as  $A_c/R_c = I_0$  from a representative blank or reference sample and  $I = A_c/R_c$  from the sample to be evaluated as per below. For CDOM measurements, the blank or reference sample is usually highly purified water, with resistance  $\geq 18.2$  M $\Omega$  and total organic carbon  $< 2$  ppb. The transmission, percent transmission and absorbance values  $Abs_\lambda$  at a given wavelength  $\lambda$  are calculated as follows:

$$T_\lambda = \left( \frac{I}{I_0} \right)$$

$$\%T_\lambda = 100 \times \left( \frac{I}{I_0} \right)$$

$$Abs = -\log(T)$$

## EEM spectral correction: blank-subtraction, Rayleigh-masking and Raman scattering

The current practice for EEMs involves measuring the excitation and emission scan-ranges, which includes their overlap regions. These overlap regions manifest in intense signals from the scattered photons from the monochromatic excitation source in the emission detector's response. These lines are caused by both the first- (and second-) order Rayleigh-scattering features consistent with the well-known grating equation. Additionally another spectral feature, associated water samples, is the water Raman scattering line. The Raman scattering line is related to the Rayleigh scattering line by a constant energy shift of 3382  $\text{cm}^{-1}$ . Most CDOM component libraries contain spectra for which the artifactual Rayleigh and water-Raman spectral features have been removed, and hence EEM data is usually processed to remove both the Rayleigh and Raman scattering features systematically. The Aqualog<sup>®</sup> software package can remove both artifacts. Subtraction of the blank EEM from the sample EEM effectively removes the Raman scatter line. Applying a Rayleigh-masking algorithm based on the excitation and emission spectral bandwidth nullifies the signal intensities for both the first- and second-order Rayleigh lines.

## EEM spectral correction: primary and secondary inner-filter effects

Common, recommended practice is to correct the EEM data for inner-filter effects (IFE) using the parallel absorbance measurements from the sample and blank as mentioned above. One obvious criterion for accurate IFE is the requirement for the concentration of the sample to fall within the linear Beer-Lambert region for the absorbance spectral region associated with the EEM. The IFE algorithms used in Aqualog<sup>®</sup> involve measuring the absorbance spectrum of the sample for the overlapping range of both the excitation and emission spectra to correct for both the primary and secondary IFEs. The basic IFE algorithm employed in the Aqualog<sup>®</sup> software requires use of conventional 1 × 1 cm path-length cuvettes. The equation below is applied to each excitation-emission wavelength coordinate of the EEM:

$$F_{\text{ideal}} = F_{\text{obs}} \times 10^{\frac{Abs_{Ex} + Abs_{Em}}{2}}$$

where  $F_{\text{ideal}}$  is the ideal fluorescence-signal spectrum expected in the absence of IFE,  $F_{\text{obs}}$  is the observed fluorescence signal, and  $Abs_{Ex}$  and  $Abs_{Em}$  are the measured absorbance values at the respective excitation and emission wavelength-coordinates.

A number of advanced algorithms described in the literature can also account for variations of the optical geometrical parameters of the cuvette path-length, beam- or slit-width, and positioning/shifting of the cuvette relative to the excitation and emission beam paths. However, the fixed optical geometry of the Aqualog<sup>®</sup> lends itself to the simple solution above because neither the slit-widths that determine the beam geometry, nor the path-lengths or overlap volume of the absorbance and emission paths are user-adjustable. Moreover, IFE corrections are generally only important when the absorbance values exceed 0.05 in a 1 cm path-length, so there is generally little information to be gained in the EEM from either an extended or shortened path-length cell. The fixed geometry of the Aqualog<sup>®</sup> further lends the use of the instrument to support valid intra- and inter-laboratory comparisons by eliminating variances in the chief parameters of absorbance and emission path-length. The fixed optical geometry also makes accurate and reproducible spectral correction easy as well as easy validation of such with standard traceable samples.

## EEM spectral correction: intensity standardization to quinine-sulfate-unit equivalents and water-Raman scattering intensity

Whereas the absorbance spectral response of the Aqualog<sup>®</sup> with respect to sample concentration is generally invariant over the lifetime of the instrument, the fluorescence-detection path is subject to changes in the excitation source's intensity and detector response that should be routinely monitored with standard samples and experimental conditions. Moreover, to ease comparison with other instruments and studies, such standardization is conventional and recommended practice. Most commonly the throughput response of a fluorometer including the Aqualog<sup>®</sup> is measured by eva-

luating the water-Raman scattering intensity under standard conditions of 350 nm excitation and 397 nm emission at 5 nm bandpass for a fixed time interval. Likewise, many CDOM studies calibrate the instrument's throughput and CDOM concentration relative to a quinine-sulfate-unit equivalent (QSU), based on the excitation at 347.5 nm of 1 ppm of QSU dissolved in 0.1 mol of perchloric acid, and the instrument measuring the emission intensity at 450 nm. The Aqualog<sup>®</sup> contains a built-in tool for calculating and applying both the water-Raman and QSU standardization and normalization.

## EEM spectral correction: nonlinear least-squares and multivariate spectral analyses

As required by the CDOM research community, the concerted application of the instrumental spectral corrections, Rayleigh-line masking, water-Raman subtraction, Raman or QSU normalization and IFE correction are readily enabled by the EEM-processing tools in our Aqualog<sup>®</sup> software. As mentioned above, the purpose of the spectral corrections and EEM-processing is to make the identification and quantification easier of the CDOM components that are usually based on a reference-component library or model. Here we focus attention on a popular and promising library-based multivariate technique for CDOM analysis, namely, PARAFAC, which has been documented extensively by researchers including many using HORIBA's fluorescence instruments. Importantly, the Aqualog<sup>®</sup> software offers direct access to a MatLab<sup>®</sup> console for purposes of processing data using the PARAFAC tools in N-way Toolbox, a public-domain package especially developed for CDOM analysis. The modeling advantages of PARAFAC center on its ability to simultaneously evaluate the EEM data as a matrix, and to envelop multiple (often hundreds) of EEMs simultaneously for increased statistical significance. PARAFAC has been successful at identifying a wide range of CDOM components including humic and fulvic acids, tryptophan- and tyrosine-like substances, quinones, several polycyclic aromatic hydrocarbons, and distinguishing microbial, marine and terrestrial CDOM sources. More importantly, PARAFAC has been used to diagnose trends in CDOM components as a function of several key chemical and physical parameters, including water-recycling-plant treatment stages, sewage dispersion, stream flow, and ocean and estuarial currents, among many others. Indeed, the application of PARAFAC has been proposed as a standard modeling technique for a variety of water-quality applications.

# Flow chart for typical Aqualog<sup>®</sup> EEM experiments for CDOM

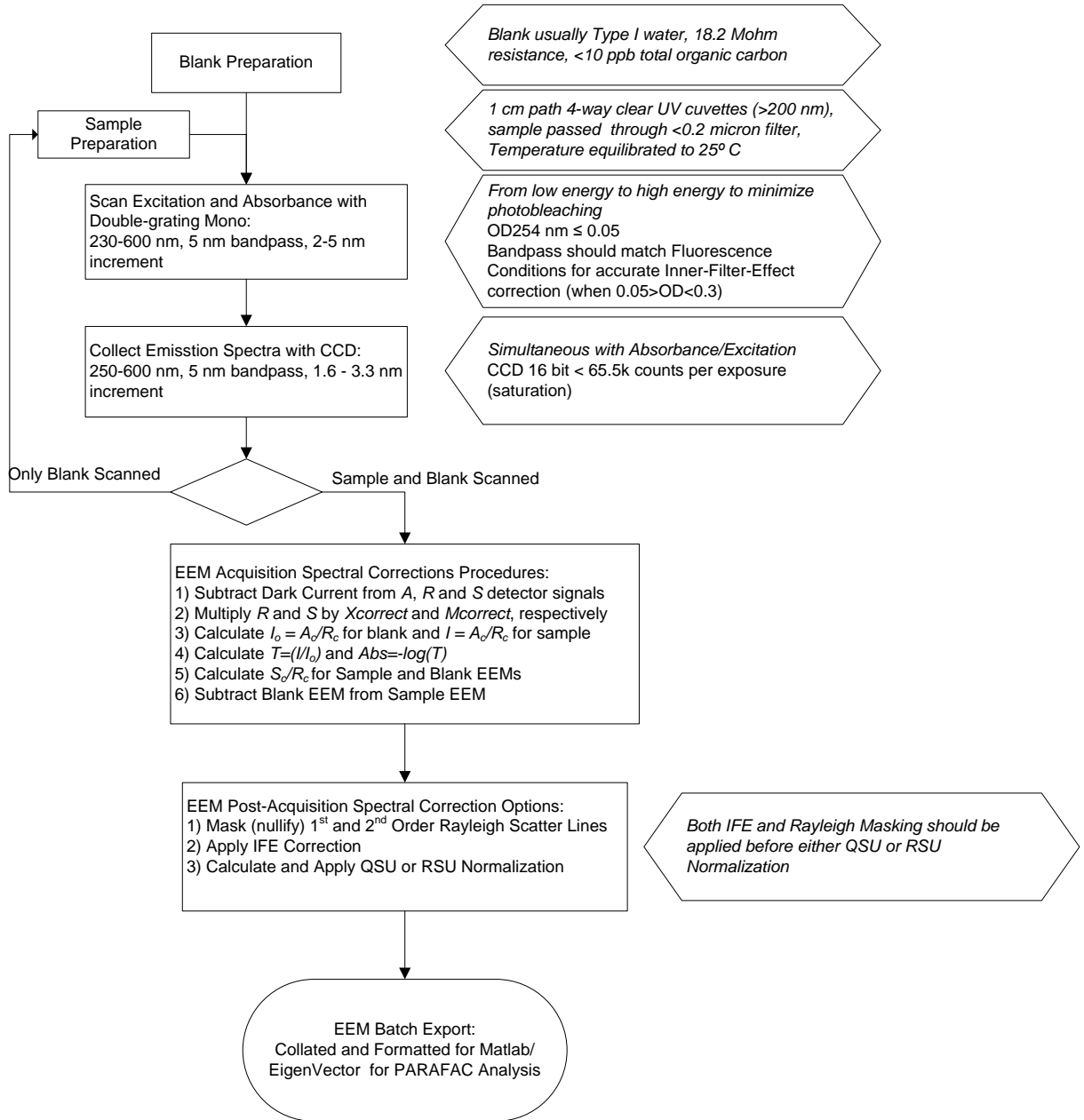

# 2: Requirements & Installation

## Safety-training requirements

Every user of the Aqualog<sup>®</sup> must know general and specific safety procedures before operating the instrument. For example, proper training includes (but is not limited to):

- Understanding the risks of exposure to ultraviolet, visible, and infrared light, and how to avoid unsafe exposures to these types of radiation
- Handling xenon-lamp bulbs, and their dangers
- Safe handling for all chemicals and other samples used in the instrument

Safety-training may be purchased from HORIBA Scientific. Contact your HORIBA Scientific representative or the HORIBA Scientific Service Department for details.

# Surface requirements

- A sturdy table- or bench-top
- Surface must hold 90 kg (200 lbs.).
- Surface should be about 27" × 72" (69 cm × 183 cm) to hold spectrofluorometer, computer, and accessories comfortably.
- Overhead clearance should be at least 36" (91 cm).



# Environmental requirements

- Temperature 59–86°F (15–30°C)
- Maximum temperature fluctuation  $\pm 2^\circ\text{C}$
- Ambient relative humidity  $< 75\%$



**Caution:** Excessive humidity can damage the optics.

- Low dust levels
- No special ventilation



**Caution:** For adequate cooling, do not cover, block, or obstruct the vents on the left side and underside of the instrument.

# Electrical requirements

The Aqualog<sup>®</sup> operates from universal AC single-phase input power over the range of 85 to 250 V AC with a line frequency of 50 to 60 Hz. This AC input power is applied to a two-pole fusing power entry module located on the side of the instrument. This module incorporates two 5 × 20 mm IEC approved, 4.0 A, 250 V, Time Delay fuses (Cooper Bussman part number GDC-4A or equivalent) to protect against line disturbances or anomalies outside the system's normal operating range.

Have enough outlets available for:

- Host computer (PC)
- Monitor
- Optional printer
- Aqualog<sup>®</sup>



**Caution:** HORIBA Instruments Incorporated is not liable for damage from line surges and voltage fluctuations. A surge protector is strongly recommended for minor power fluctuations. For more severe voltage variations, use a generator or uninterruptible power supply. **Improper line voltages can damage the equipment severely.**



**Warning:** The Aqualog<sup>®</sup> is equipped with a three-conductor power cord that is connected to the system frame (earth) ground. This ground provides a return path for fault current from equipment malfunction or external faults. For all instruments, ground continuity is required for safe operation. Any discontinuity in the ground line can make the instrument unsafe for use. **Do not operate this system from an ungrounded source.**



**Note:** HORIBA Scientific recommends connecting the host computer, monitor, and printer to a single surge-protector, to make start-up more convenient, and to conserve AC outlets. Connect the Aqualog<sup>®</sup> to a separate line, if possible, to isolate the xenon-lamp power supply inside the Aqualog<sup>®</sup>.

# Unpacking and installation

## Introduction

The Aqualog<sup>®</sup> spectrofluorometer system is delivered in a single packing carton. If a host computer (PC) is ordered as a part of the system, the PC is delivered in a few clearly labeled boxes. All accessories, cables, software, and manuals ordered with the system are included with the delivery.

Examine the shipping boxes carefully. Any evidence of damage should be noted on the delivery receipt and signed by representatives of the receiving and carrier companies. Once a location has been chosen, unpack and assemble the equipment as described below. To avoid excessive moving and handling, the equipment should be unpacked as close as possible to the selected location.



**Note:** Many public carriers will not recognize a claim for concealed damage if it is reported later than 15 days after delivery. In case of a claim, inspection by an agent of the carrier is required. For this reason, the original packing material should be retained as evidence of alleged mishandling or abuse. While HORIBA Instruments Incorporated assumes no responsibility for damage occurring during transit, the company will make every effort to aid and advise.



**Caution:** The spectrofluorometer system is a delicate instrument. Mishandling may seriously damage its components.

## Aqualog<sup>®</sup> carton contents

Quantity	Item	Part number
1	Aqualog <sup>®</sup>	
1	USB cable	J980087
1	Aqualog Operation Manual	J810012
1	Set of Allen wrenches (Allen keys)	53057
1	Single-cell sample-holder	351697
1	Power cord (110 V)	98015
	(220 V)	98020
1	Aqualog <sup>®</sup> software package	

## Directions

### 1 Unpack and set up the Aqualog<sup>®</sup>.

- a Carefully open the Aqualog<sup>®</sup> shipping carton.
- b Remove the foam-injected top piece and any other shipping restraints in the carton.
- c With assistance, carefully lift the instrument from the carton, and rest it on the side of the laboratory bench where the system will stay.

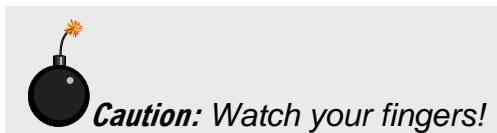

- d Place the instrument in its permanent location.
- e Level the spectrofluorometer.  
Adjust the four leveling feet on the bottom of the instrument.
- f Inspect for previously hidden damage.  
Notify the carrier and HORIBA Scientific if any is found.
- g Check the packing list to verify that all components and accessories are present.

- h Plug one end of the power cord into the proper receptacle on the left side (while facing the unit) of the spectrofluorometer.

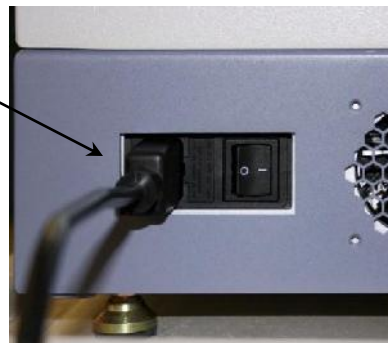

- i Plug one end of the USB cable into the USB receptacle.

- j With an optional trigger accessory, plug one end of the trigger cable into the TRIGGER IN

connector on the Aqualog<sup>®</sup>. Allow the un-connected ends of the cables to dangle freely; they will be connected in later steps.



## 2 Set up the computer.

The information gathered by the spectrofluorometer system is displayed and controlled through the host PC via Aqualog<sup>®</sup> software. The host PC may be purchased from HORIBA Scientific or another supplier.

- a Set up the host PC reasonably close to the Aqualog<sup>®</sup> system. The limitation is the length of the USB cable. The recommended location for the PC is just to the right of the spectrofluorometer, but other positions are possible.
- b Follow the instructions for the host PC to set up the computer system, including the CPU, monitor, keyboard, mouse, speakers, printers, etc.

## 3 Connect the Aqualog<sup>®</sup> to the computer.

- a Attach the free end of the USB cable to a USB receptacle on the host computer.
- b With all devices OFF, plug the power cords from the monitor, host computer, Aqualog<sup>®</sup>, and the printer into properly grounded receptacles.
- c Install any accessories that arrived with the system, using the instructions that accompany the accessories.  
See Chapter 10 for a detailed list of accessories.

## 4 Install the Aqualog<sup>®</sup> software.

The spectrofluorometer system is controlled by Aqualog<sup>®</sup> spectroscopy software operating within the Windows<sup>®</sup> environment. If the computer and software were purchased from HORIBA Scientific, the software installation is complete. If the computer is not from HORIBA Scientific, perform the installation. Contact a HORIBA Scientific Sales Representative for recommended specifications for a suitable host computer.

Before the Aqualog<sup>®</sup> software can be installed, however, Windows<sup>®</sup> must be installed already and operating properly. Refer to the Windows<sup>®</sup> manual that came with the computer for installation instructions.

The Aqualog<sup>®</sup> software is supplied on one DVD. Follow the *Aqualog<sup>®</sup> User's Guide* for details on installation.



**Note:** Be sure to agree to the terms of the software license before using the software.

A USB dongle is supplied with Aqualog<sup>®</sup> software. This dongle (license) must be connected to the host PC before the Aqualog<sup>®</sup> software will operate.

**Users outside of the USA:**

Users outside of the USA receive a softkey device that connects to the printer port of the host computer for software security. The softkey should be left in place on the host computer at all times.



**Note:** Copying, disassembly, or removal of the softkey is illegal.

# Software emulation

Emulating the Aqualog<sup>®</sup> software means letting the host computer act as though the Aqualog<sup>®</sup> is properly connected, even if it isn't.

- 1 Disconnect the communications cable from the host computer to the Aqualog<sup>®</sup>.



**Note:** Be sure the Aqualog<sup>®</sup> USB key is inserted into a free USB port on the host computer. Without the key, the Aqualog<sup>®</sup> software will not run properly, even in emulation mode.

- 2 Double-click the software icon to start the Aqualog<sup>®</sup> software.

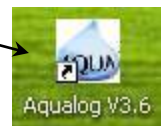

The instrument initializes, then the **Aqualog** main window appears. If there are any difficulties, see the troubleshooting chapter.

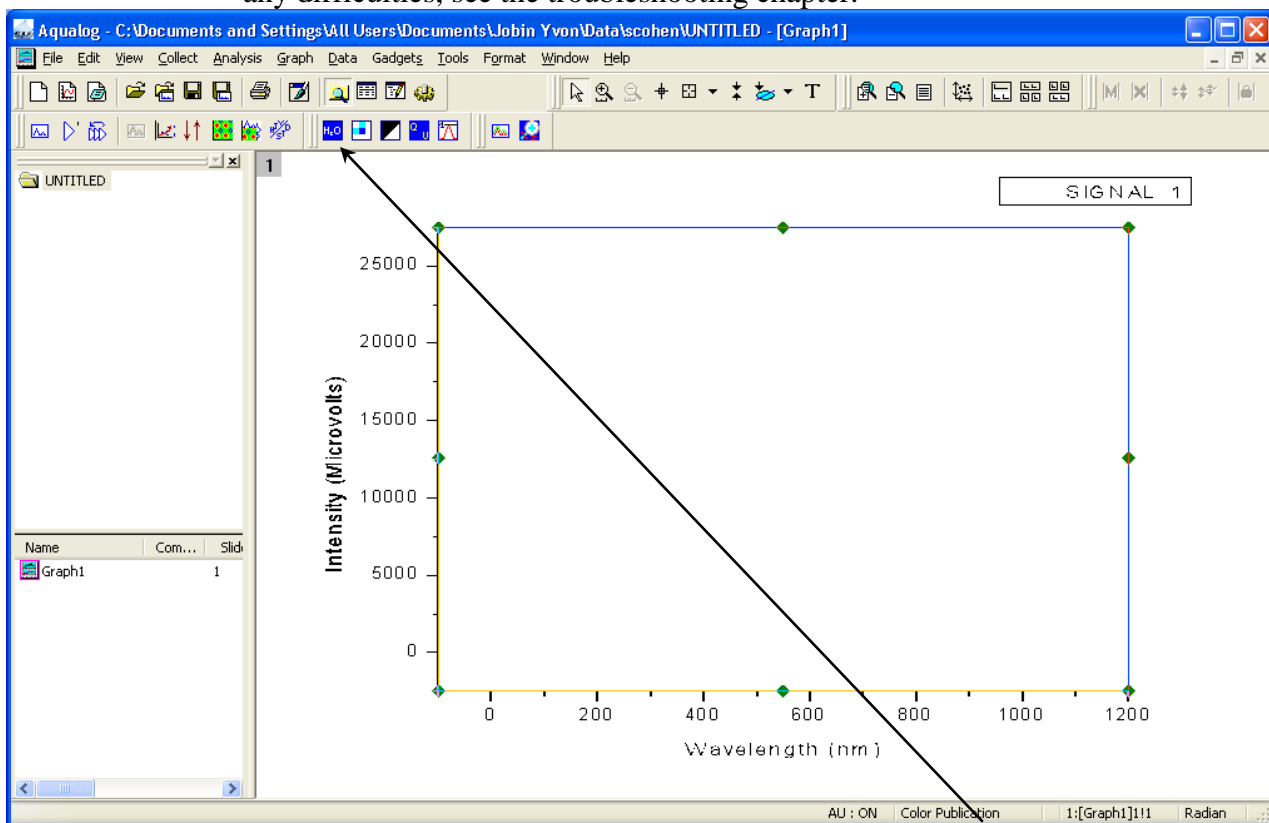

- 3 Click the Experiment Menu button .

The **System Initialization Process** window appears:

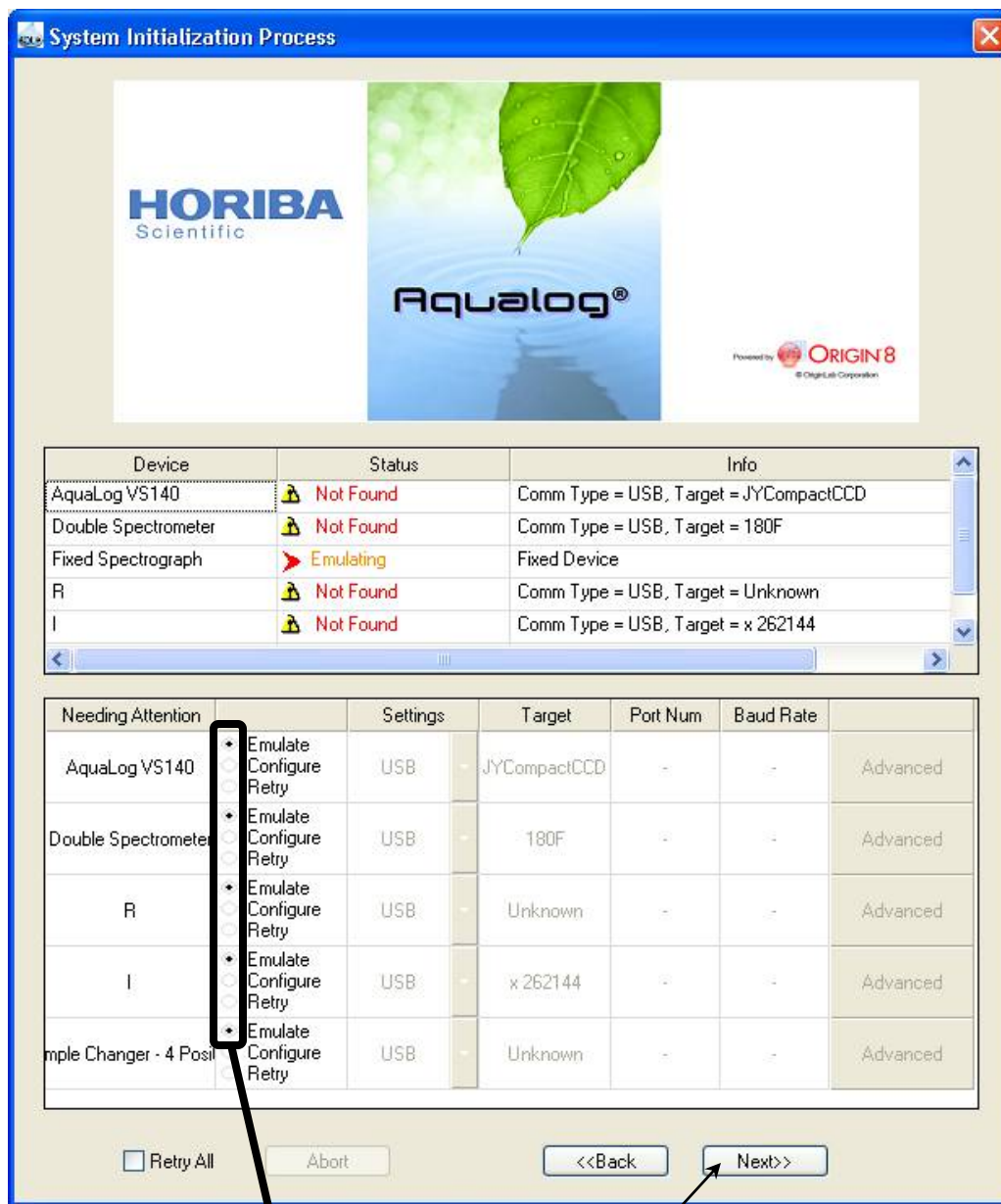

4 Choose the Emulate buttons for all components, then click the Next>> button.

The **Aqualog Main Experiment Menu** opens:

5 Choose an experiment type by clicking one of the four buttons.

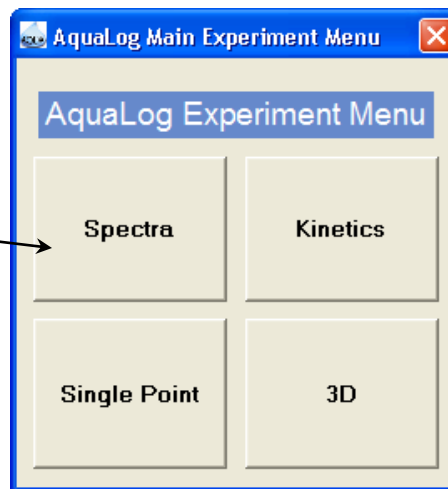

The **Aqualog Experiment Type** window appears (if that experiment has subtypes):



6 Choose a sub-type of experiment, and click the Next >> button.

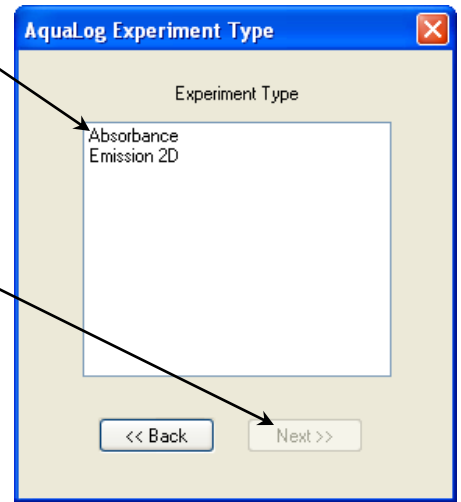

The **Aqualog Experiment Setup** window appears:

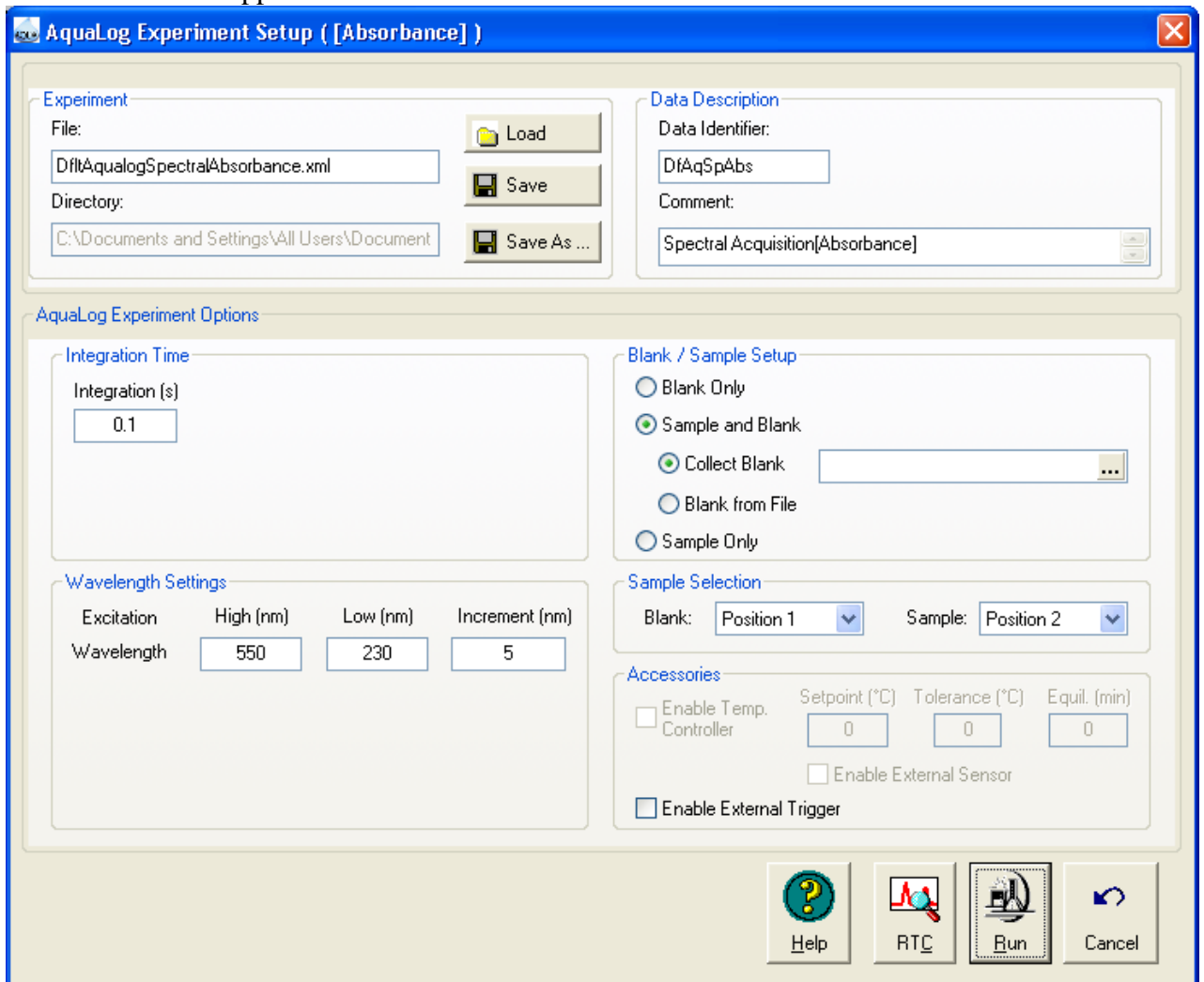

Aqualog<sup>®</sup> software is now emulating the instrument.



# 3 : System Description



**Warning:** Do not open the instrument without proper training, appropriate protection, and having read this operation manual. The instrument contains dangerous voltages, ultraviolet, visible, and infrared radiation, and fragile light-sources. In addition, tampering with the optical components can irreversibly damage them.

## Introduction

A spectrofluorometer is an analytical instrument used to measure and record the fluorescence of a sample. While recording the fluorescence, the excitation, emission, or both wavelengths may be scanned. With additional accessories, variation of signal with time, temperature, concentration, polarization, or other variables may be monitored.

To measure absorbance, light is shone into the sample, and how much the signal is diminished by traveling through the sample is measured by the detector.

## Basic theory of operation

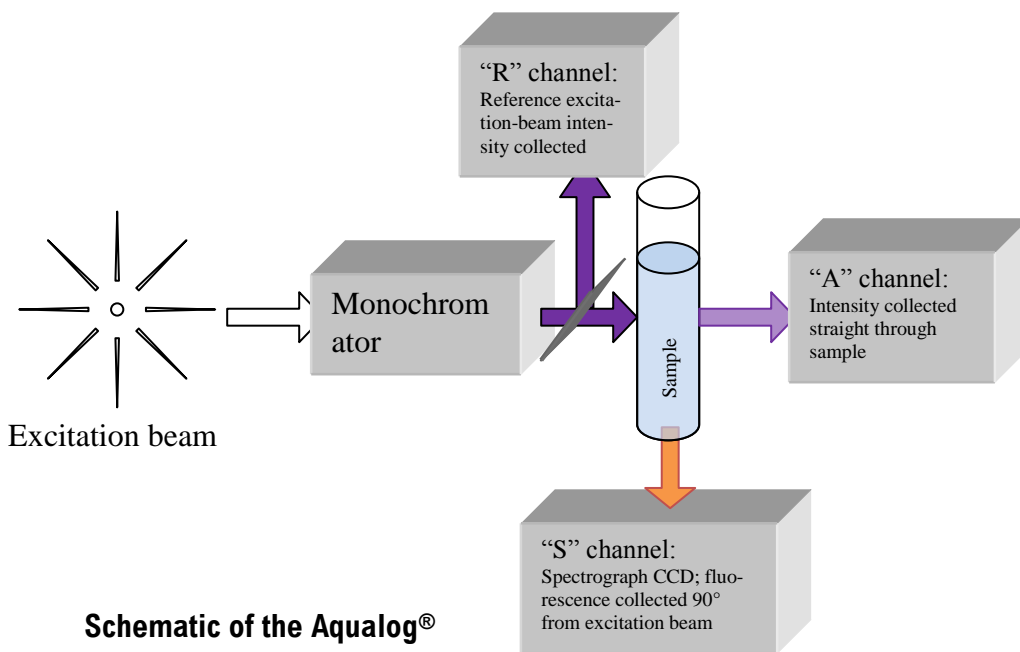

A continuous source of light shines onto an excitation monochromator, which selects a band of wavelengths. This monochromatic excitation light is mostly directed onto a

sample, which emits luminescence; a small portion of the excitation light shines onto a reference detector, to use as a normalization for excitation-lamp variations. At right-angles to the excitation beam, the sample's luminescence is directed into a multichannel CCD detector, which reports a fluorescence spectrum. Colinear with the beam, the sample's luminescence is also directed into a single-channel detector. The signals from the detectors are reported to a system controller and host computer, where the data can be manipulated and presented, using special software.

# Optical layout

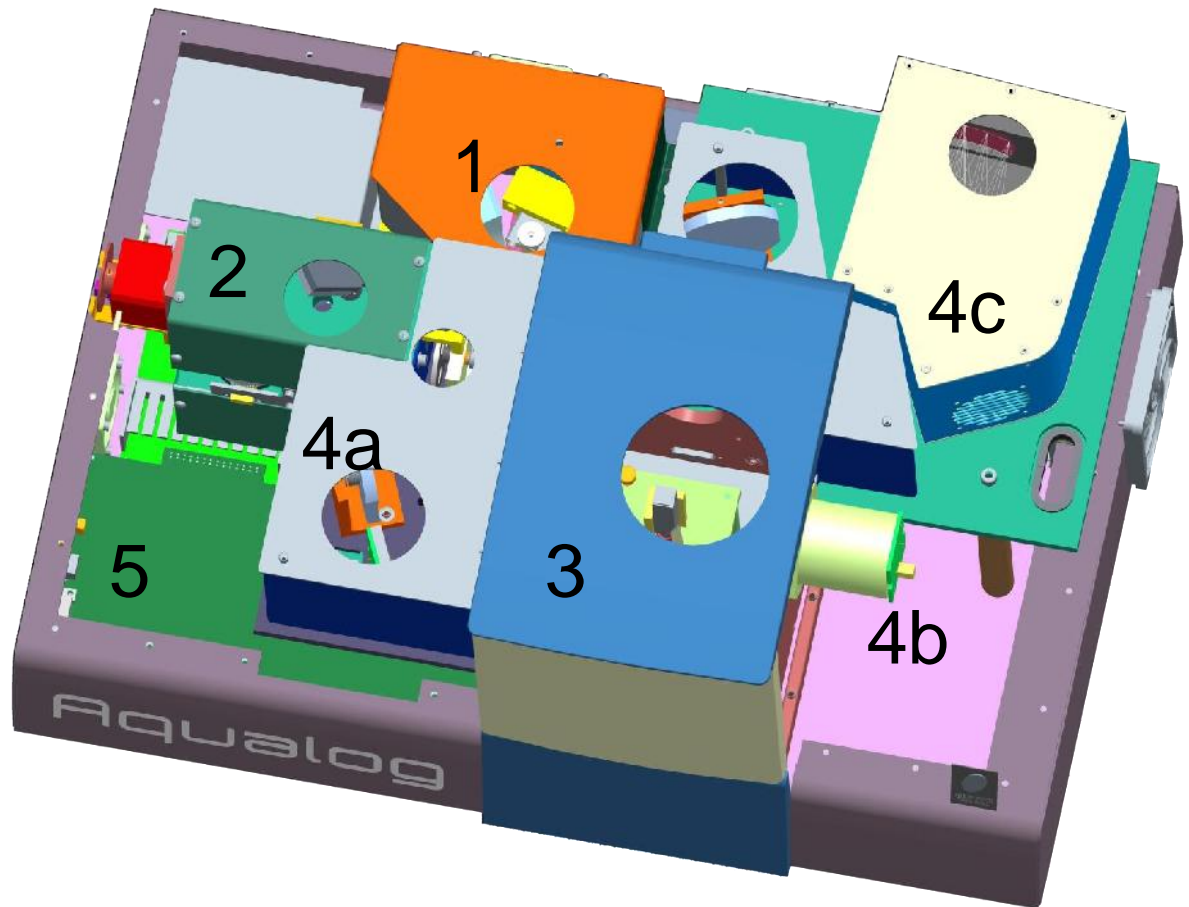

## Illuminator (xenon arc-lamp, 1)

The continuous light source is a 150-W ozone-free xenon arc-lamp. Light from the lamp is collected by a diamond-turned elliptical mirror, and then focused on the entrance slit of the excitation monochromator. The lamp housing is separated from the excitation monochromator by a quartz window. This vents heat out of the instrument, and protects against the unlikely occurrence of lamp failure.



## Monochromator (2)

The Aqualog<sup>®</sup> contains a monochromator for selection of the excitation beam.

### Gratings

The essential part of a monochromator is a reflection grating. A grating disperses the incident light by means of its vertical grooves. A spectrum is obtained by rotating the gratings, and recording the intensity values at each wavelength. The gratings in the Aqualog<sup>®</sup> contain 1200 grooves  $\text{mm}^{-1}$ , and are blazed at 250 nm (excitation). Blazing is etching the grooves at a particular angle, to optimize the grating's reflectivity in a particular spectral region. The wavelengths selected are optimal for excitation in the UV and visible. The grating is coated with  $\text{MgF}_2$  for protection against oxidation. The system uses a direct drive for the grating, to scan the spectrum at up to  $500 \text{ nm s}^{-1}$ , with accuracy better than 1.0 nm.

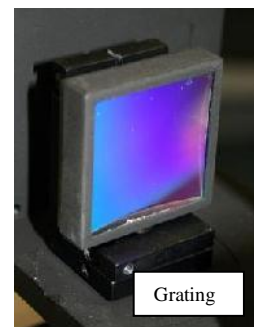
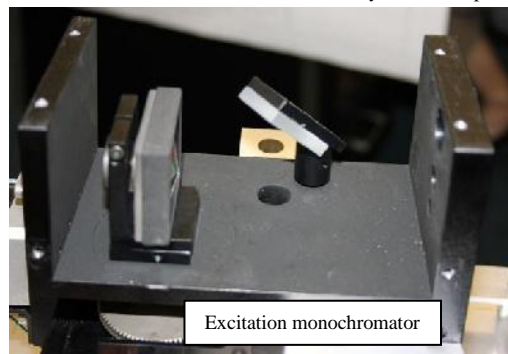

### Slits

The entrance and exit ports of the monochromator have fixed slits set to 5 nm bandpass. The bandpass is determined by the dispersion of the monochromator:

$$\text{bandpass (in nm)} = \text{slit width (in mm)} \times \text{dispersion (in nm mm}^{-1}\text{)}$$

The dispersion of the Aqualog<sup>®</sup> monochromator is  $4.25 \text{ nm mm}^{-1}$  for gratings with 1200 grooves  $\text{mm}^{-1}$  at 540 nm.

### Shutters

An excitation shutter, standard on the Aqualog<sup>®</sup>, is located just after the excitation monochromator's exit slit. The shutter protects samples from photobleaching or photodegradation from prolonged exposure to the light source. Aqualog<sup>®</sup> software controls the shutter, and can set the shutter to automatic or photobleach modes.



**Caution:** Operation of the instrument when the excitation shutter is disabled may expose the user to excessive light. Wear light-blocking goggles or face-shield, and light-blocking clothing and gloves.

## Sample compartment (3)

A toroidal mirror focuses the beam from the excitation monochromator on the sample. Just before the sample compartment, about 8% of this excitation light is split off, using a beam-splitter, to the reference photodiode. Fluorescence from the sample is then collected at right-angles to the beam, and directed to the multichannel CCD detector.

The sample compartment accommodates various optional accessories, as well as fiber-optic bundles to take the excitation beam to a remote sample, and return the emission beam to the detectors. See Chapter 10 for a list of accessories.

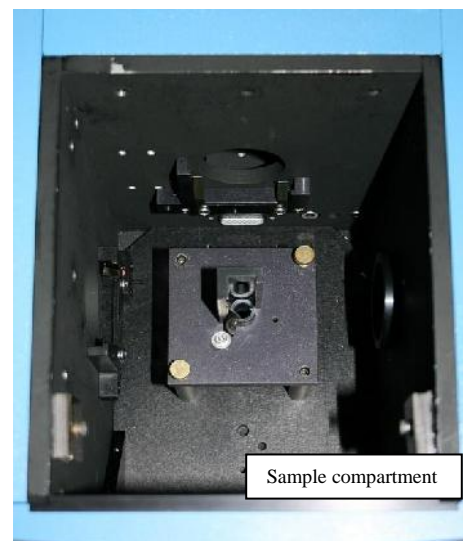

### To insert or remove a sample platform,

- 1 If a multiple-sample turret is installed, shut off the system.
- 2 Remove the four screws on the front of the sample platform.
- 3 Slide out the old platform.
- 4 Slide in the new platform.
- 5 If the platform has a rotatable turret or magnetic stirrer, slide the 15-pin connector gently and securely onto the 15-pin receptacle in the sample compartment.
- 6 Re-attach the four screws on the front of the sample platform.

## Detectors (4)

Each Aqualog<sup>®</sup> contains three detectors:

- Reference detector (4a)

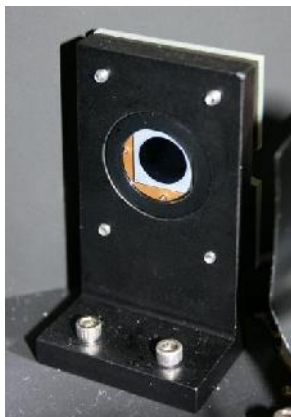

The reference detector (mentioned above) monitors the xenon lamp, in order to correct for wavelength- and time-dependent output of the lamp. This detector is a UV-enhanced silicon photodiode, which is just before the sample compartment. It requires no external bias, and has good response from 190–980 nm.

- Absorption signal detector (4b)

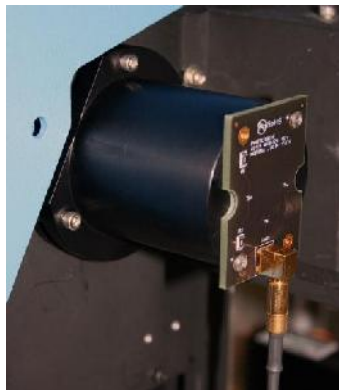

The standard absorption signal detector is also a UV-enhanced silicon photodiode, which is after the sample perpendicular to the excitation beam. It requires no external bias, and has good response from 190–980 nm.

- Fluorescence detector (4c)



At right-angles to the excitation-beam direction is a multichannel CCD detector, to record a full spectrum of luminescence from the sample.

The reference and signal detectors have correction-factor files run for them, to correct for wavelength dependencies of each optical component. The files are created at HORIBA Scientific for every instrument, and are automatically applied to data through Aqualog<sup>®</sup> software. See Chapter 6 for more details.

## Electronics and controllers (5)

The front bottom of the Aqualog<sup>®</sup> houses the electronics for running the lamp, instrument, scans, and measurements.



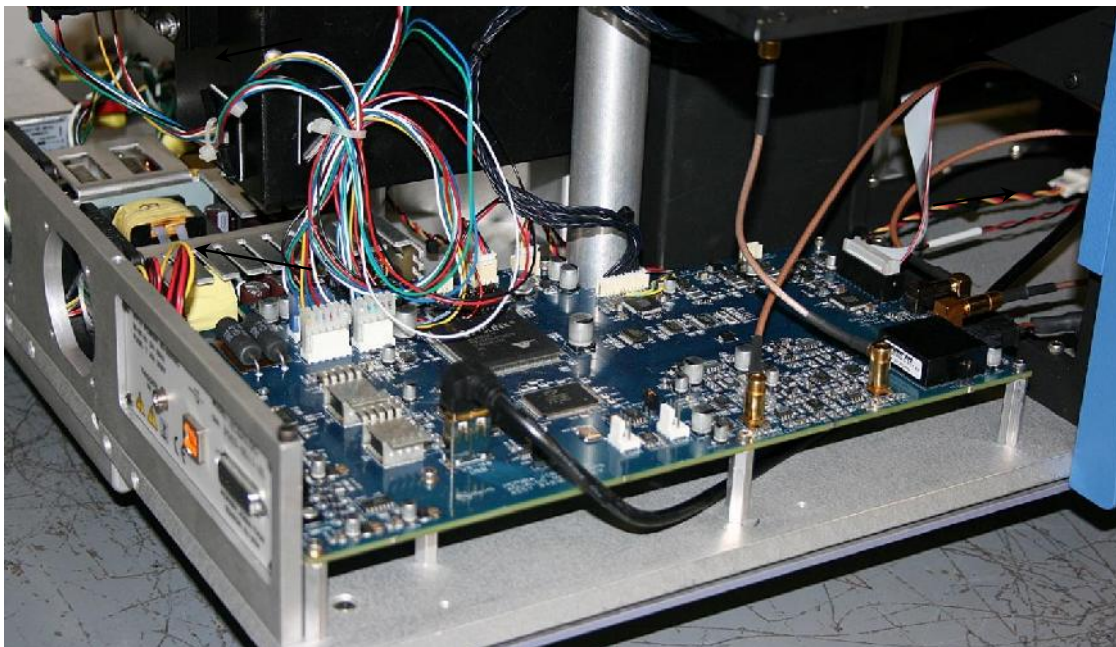

## Computer system and software (not on diagram)

Not shown on the schematic is the host computer with Aqualog<sup>®</sup> software. The technical specifications chapter lists the computer requirements. An optional printer or network card is useful for printing. Aqualog<sup>®</sup> software for Windows<sup>®</sup> controls all interaction with the spectrofluorometer. For information on Aqualog<sup>®</sup> software, see the *Aqualog<sup>®</sup> Software User's Guide* and the on-line help files within Aqualog<sup>®</sup> software.



# 4: System Operation

## Introduction

This chapter explains how to turn on the Aqualog<sup>®</sup> system, check its calibration, and, if necessary, recalibrate the monochromators. While doing these procedures, how to define a scan, run a scan, and optimize system settings to obtain the best results is explained.

## Power switch

The power switch is located on the lower left-hand side of the instrument. When switched on, the xenon lamp arcs initially, and the Aqualog<sup>®</sup> turns on, runs through self-diagnostics, then starts the xenon lamp.

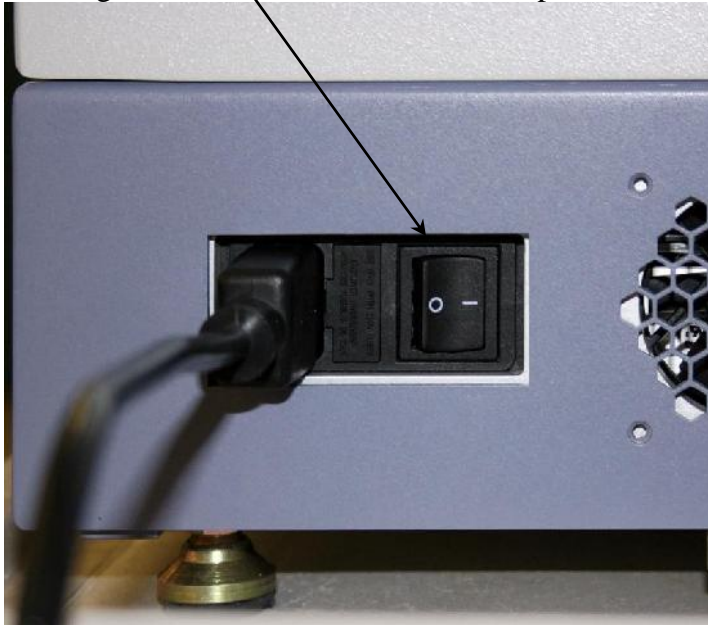

**Note:** Each time the xenon lamp is ignited adds one more hour to lamp use. HORIBA Scientific suggests leaving the lamp on during brief periods of inactivity.

# Turning on the system



**Warning:** When the xenon lamp is ignited, a large voltage is applied across the lamp. Therefore, never operate the lamp with the cover removed. An extremely rare occurrence is the explosion of the xenon lamp upon ignition. Therefore, take care in case tiny lamp shards exit the ventilation fans.

## 1 Turn on the Aqualog®.

Turn the power switch to the ON (1) position.

## 2 Turn on all peripheral devices for the host PC.

Peripherals include any printers or plotters.

## 3 Start the host computer.

- a Switch on the host computer.
- b Click the Aqualog icon on the Windows® desktop. 
- c The instrument initializes, then the **Aqualog** window appears. If there are any difficulties, see the troubleshooting chapter.

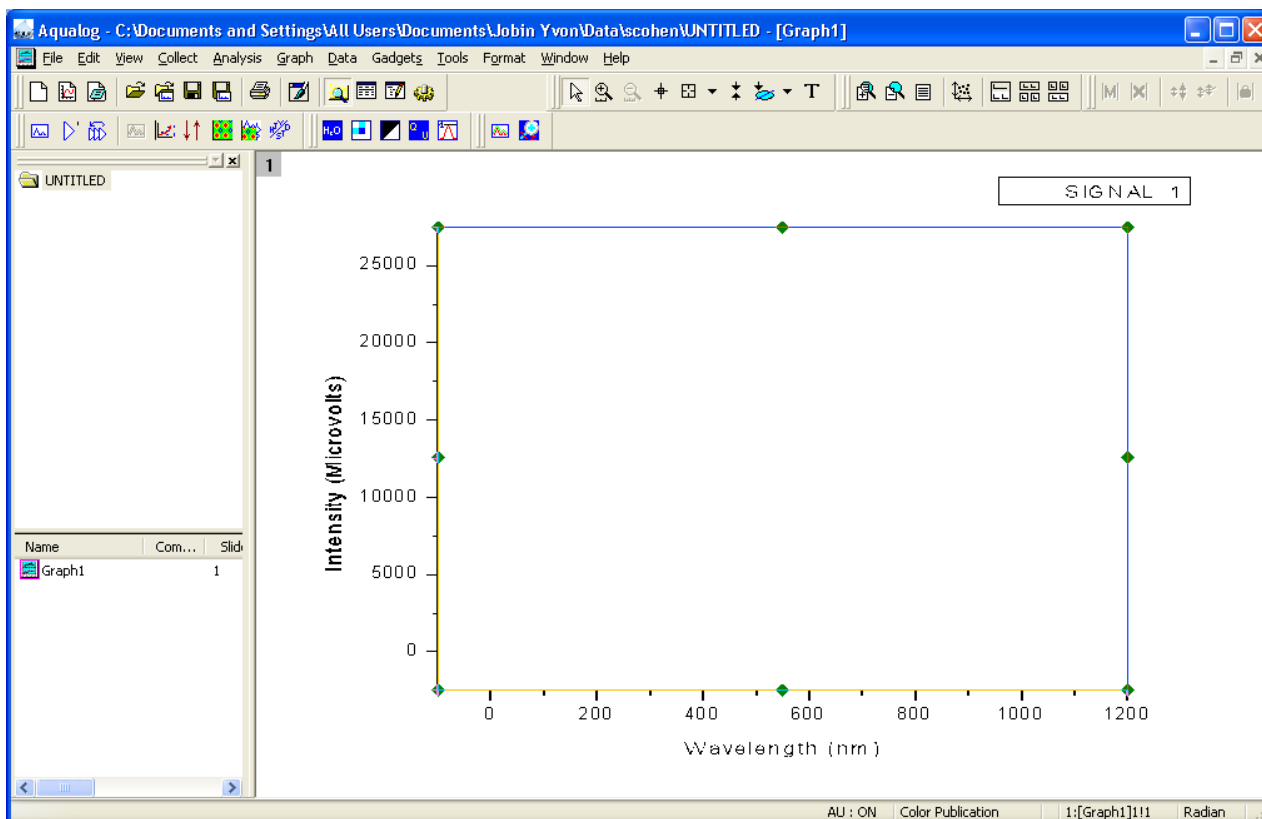

# Validating system performance

## Introduction

Upon installation and as part of occasional maintenance checks, examine the performance of the Aqualog<sup>®</sup>. In the Aqualog<sup>®</sup> software, there are a number of validation tests to be performed. HORIBA Scientific recommends running these validation tests every three months.

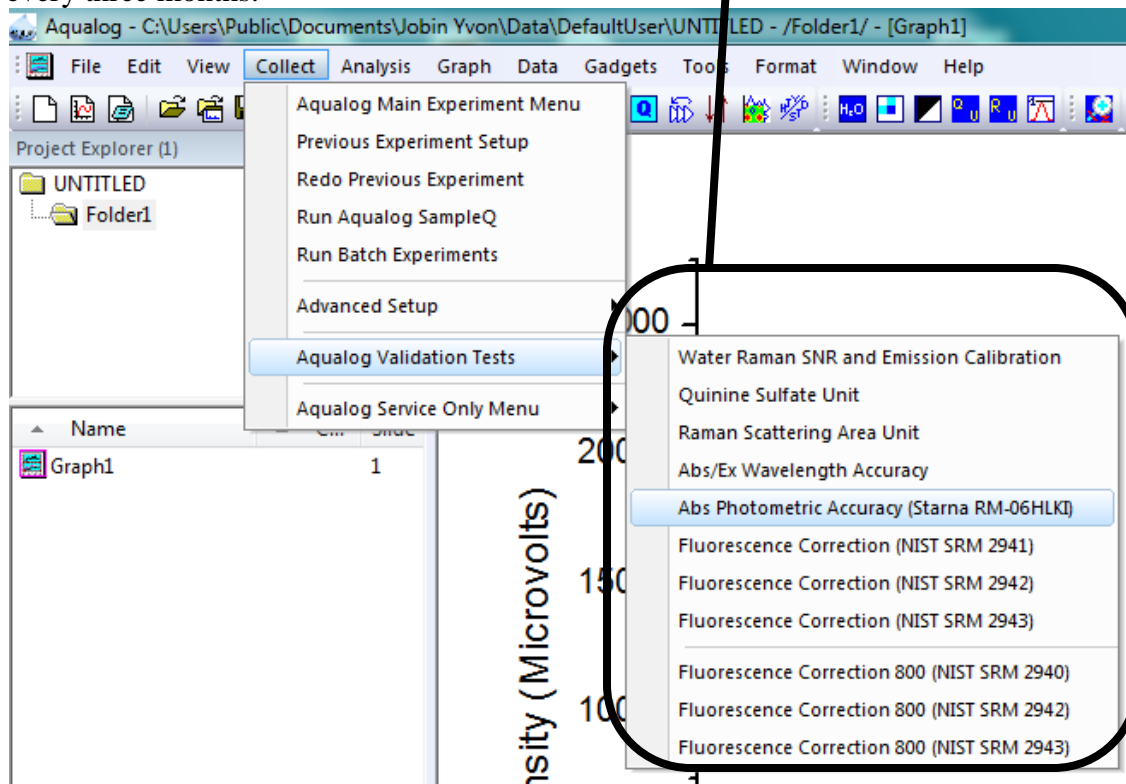

The Aqualog<sup>®</sup> is an autocalibrating spectrofluorometer. This means the system initializes its monochromators' drives, locates the home position of the each drive, and assigns a wavelength value to this position from a calibration file. For the calibration checks detailed here, a single-sample mount or automated sample changer should be the only sample-compartment accessories used.

The scans shown herein are *examples*. A Performance Test Report for your new instrument is included with the documentation. Use the Performance Test Report to validate the spectral shape and relative intensity taken during the calibration checks.



**Note:** HORIBA Instruments Incorporated is not responsible for customer errors in calibration. To be sure that your instrument is properly calibrated, call Service for assistance. We can arrange a visit and calibrate your instrument for a fee.

## Absorbance/excitation wavelength accuracy validation

This validation check examines the accuracy of the wavelengths scanned using the xenon lamp and absorbance detector, using the Starna RM sample.

- 1 Start the Aqualog<sup>®</sup> software.
- 2 In the **Aqualog** main window, choose **Collect**.

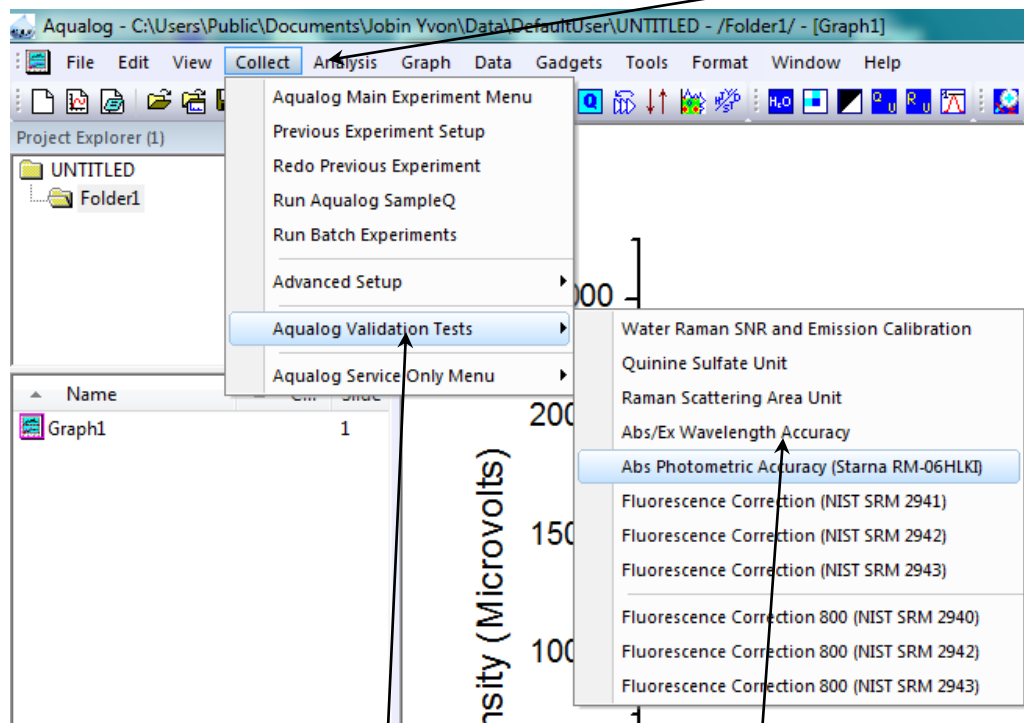

A drop-down menu appears.

- 3 Choose **Aqualog Validation Tests**.

Another drop-down menu appears.

- 4 Choose **Abs/Ex Wavelength Accuracy**.



**Note:** The Absorption/Excitation standard kit with holmium oxide, Starna RM06-HLKI, is available from Starna Cells, Inc., 5950 Traffic Way, Atascadero, CA 93422; phone: 800-228-4482; 805-466-8855; website is [www.starnacells.com](http://www.starnacells.com)

If the instrument has not initialized, initialization occurs. The validation experiment automatically loads with some of the fields grayed out:

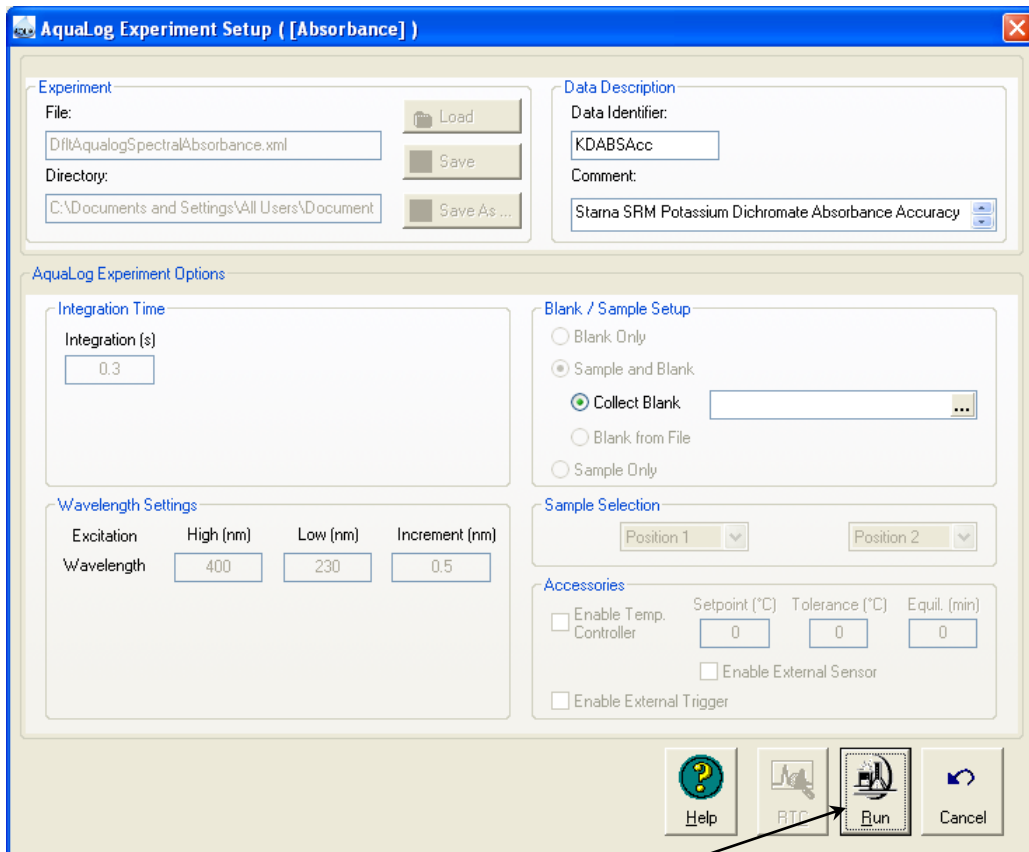

5 Click the Run button .

A message telling you to insert the blank appears:



6 Insert the  $K_2Cr_2O_7$  blank with the frosted side toward the front of the instrument, and the clear sides toward the left and right of the instrument.

This allows a clear optical path.

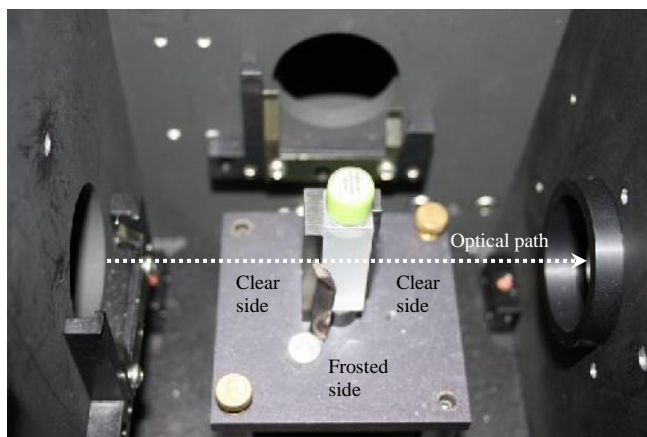
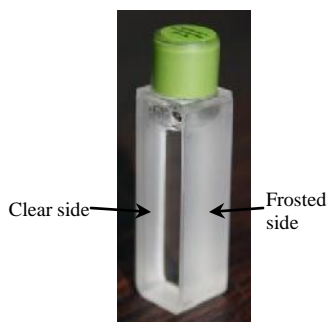



- 7 Close the sample-compartment lid, and click the OK button.

The **Experiment Status** window opens.  
The validation scan runs.

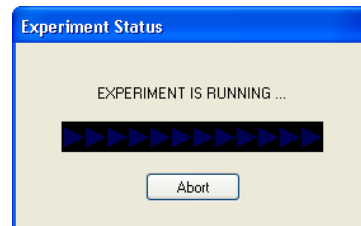

- 8 Remove the  $K_2Cr_2O_7$  blank, and insert the holmium oxide sample.
- 9 Close the sample-compartment lid, and click the OK button.

The **Experiment Status** window opens again, and the validation scan runs.

The **Project name** window appears:

- 10 Click the Cancel button.

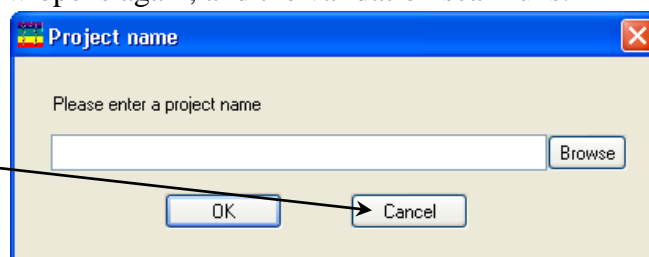

A table of the validation test appears. In the B(Y2) column, there should be all P's (passes).

Comments	pox(X1)	poy(Y1)	C1(X2)	A(Y2)	B(Y2)
Long Name	X	Y			Pass/Fail
1	333.9	0.06208	333.47		P
2	345.9	0.06243	345.59		P
3	361.2	0.22742	361.13		P
4	386.8	0.06486	386.44		P
5	417.6	0.29238	417.32		P
6	451.2	0.58843	451.4		P
7					
8					
9					
10					
11					
12					
13					
14					
15					
16					
17					
18					
19					
20					
21					
22					
23					
24					
25					
26					
27					
28					
29					
30					
31					

- 11 If the test shows all “Pass” values, continue to the next test.

If there are failures, please call the HORIBA Scientific Service Department.



# Absorption-accuracy validation

This validation check examines the accuracy of the absorption function of the Aqualog®. Use the absorption standard, RM-06HLKI-R, from Starna Cells, Inc.



**Note:** The absorbance calibration standard kit, RM-06HLKI-R, is available from Starna Cells, Inc., 5950 Traffic Way, Atascadero, CA 93422; phone: 800-228-4482; 805-466-8855; web-site is [www.starnacells.com](http://www.starnacells.com). Use the K<sub>2</sub>Cr<sub>2</sub>O<sub>7</sub> blank from Starna Cells as well.

## 1 In the Aqualog main window, choose Collect.

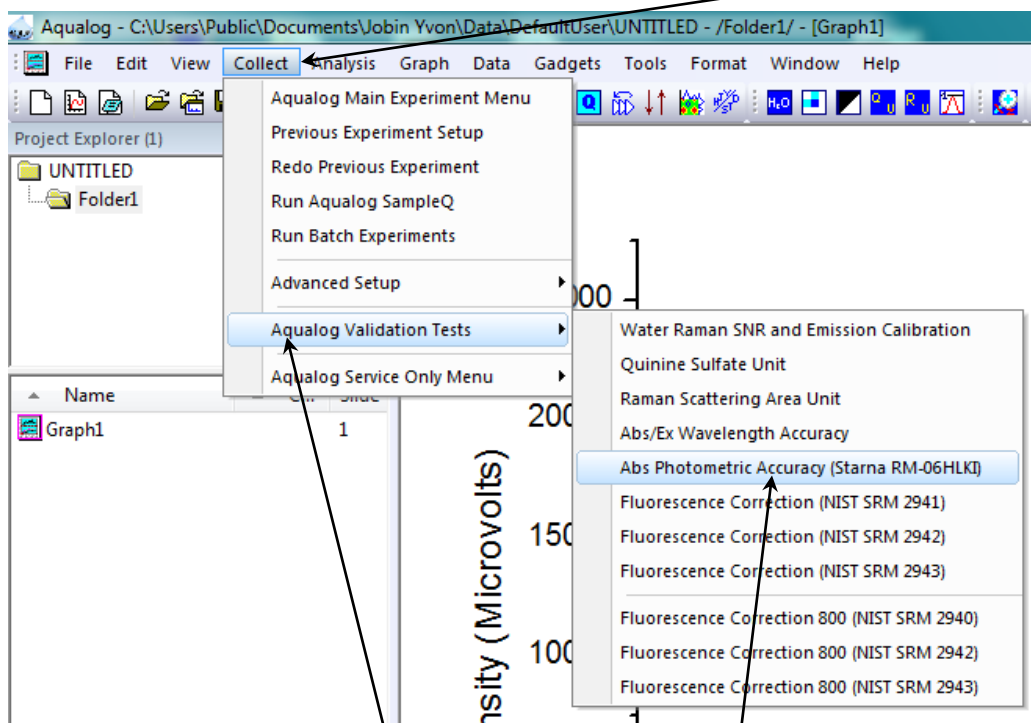

A drop-down menu appears.

## 2 Choose Aqualog Validation Tests.

Another drop-down menu appears.

## 3 Choose Abs Photometric Accuracy (Starna RM-06HLKI).

The validation experiment automatically loads with some of the fields grayed out:

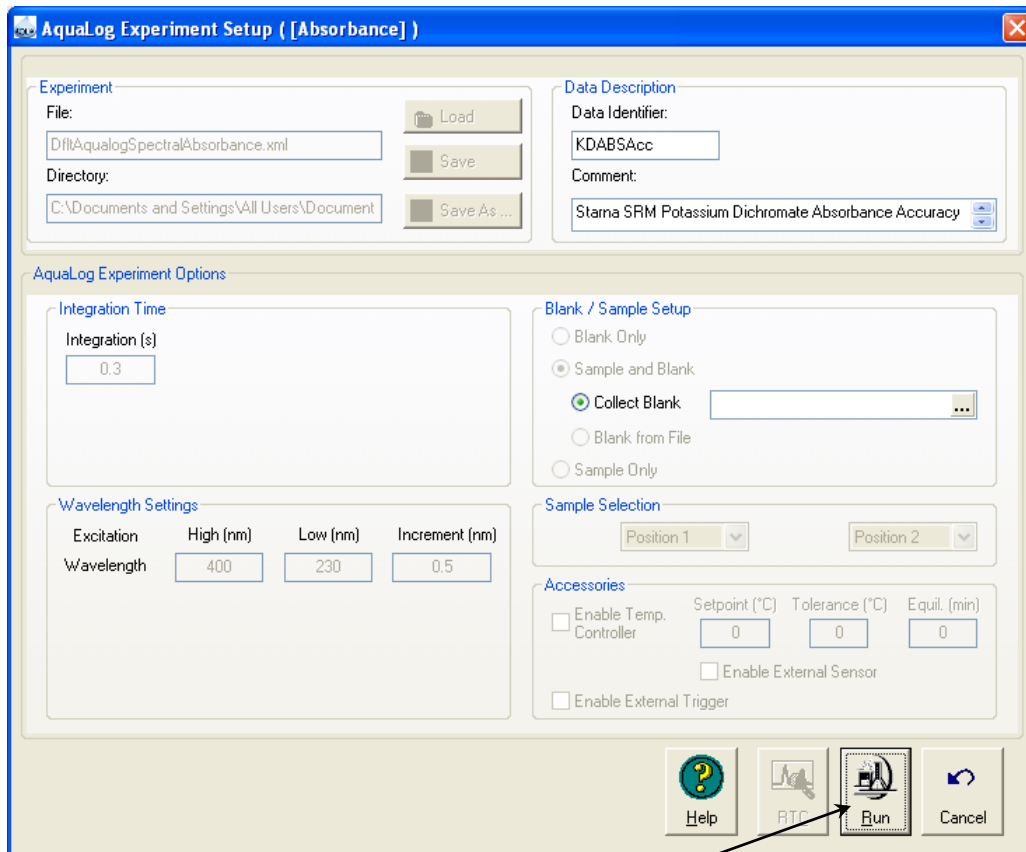

4 Click the Run button

A message telling you to insert the blank appears:



5 Insert the  $K_2Cr_2O_7$  blank with the frosted side toward the front of the instrument, and the clear sides toward the left and right of the instrument.

This allows a clear optical path.

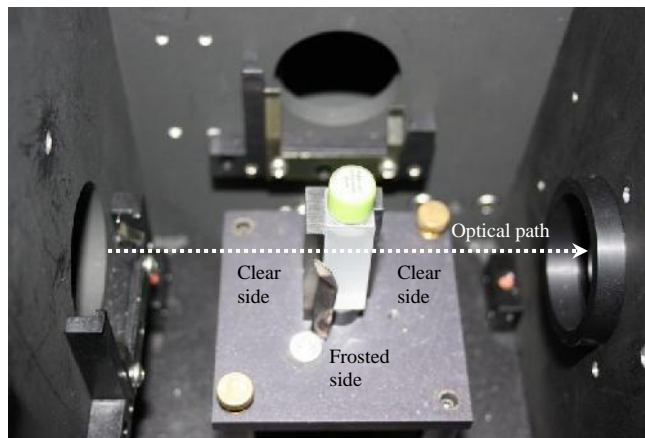
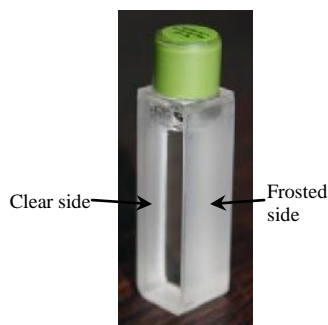

- 6 Close the sample-compartment lid, and click the OK button.

The **Experiment Status** window opens.  
The blank scan runs.

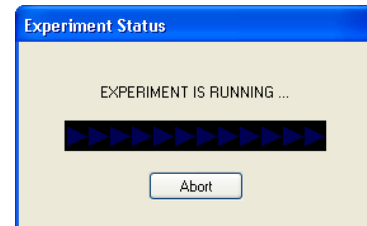

- 7 Remove the blank, and insert the  $Kr_2Cr_2O_7$  sample when prompted.

- 8 Close the sample-compartment lid, and click the OK button.

The **Experiment Status** window opens. The validation scan runs.

The **Project name** window appears:

- 9 Click the Cancel button.

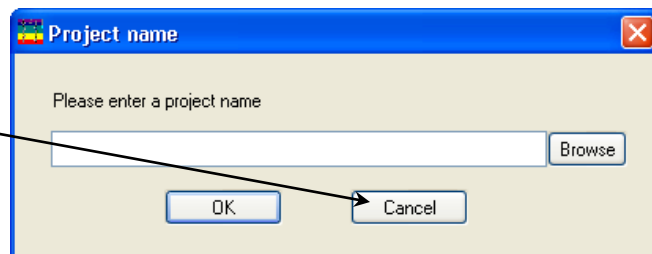

A spreadsheet of the validation test appears.

- 10 If you are using a different standard than supplied with the system:

(If not, continue with step 9.)

- a Enter the serial number of the other standard in the cell labeled SN:

	A(X)	B(Y)	C(Y)	D(Y)	E(Y)	F(Y)
Long Name	Wavelength	Certified value	Tolerance +/-	Measured value	Error	Pass/Fail
Units	nm	AU	AU	AU	AU	
Comments	SN: 13468					
1	350.0	0.628	0.010	0.628	0.000	P
2	313.0	0.288	0.010	0.288	0.000	P
3	257.0	0.848	0.010	0.848	0.000	P
4	235.0	0.732	0.010	0.732	0.000	P

- b Enter the new numbers for Certified Value in the B(X) cells (rows 1 through 4):

	A(X)	B(Y)	C(Y)	D(Y)	E(Y)	F(Y)
Long Name	Wavelength	Certified value	Tolerance +/-	Measured value	Error	Pass/Fail
Units	nm	AU	AU	AU	AU	
Comments	SN: 13468					
1	350	0.628	0.010	0.628	0.000	P
2	313	0.288	0.010	0.288	0.000	P
3	257	0.848	0.010	0.848	0.000	P
4	235	0.732	0.010	0.732	0.000	P

# 11 Verify the results of the test:

In the F(Y) column, there should be all P's (passes).

	A(X)	B(Y)	C(Y)	D(Y)	E(Y)	F(Y)
Long Name	Wavelength	Certified value	Tolerance +/-	Measured value	Error	Pass/Fail
Units	nm	AU	AU	AU	AU	
Comments	SN: 13468					
1	350.0	0.628	0.010	0.628	0.000	P
2	313.0	0.288	0.010	0.288	0.000	P
3	257.0	0.848	0.010	0.848	0.000	P
4	235.0	0.732	0.010	0.732	0.000	P
5						

# 12 If the test shows all “Pass” values, continue to the next test.

If there are failures, please call the HORIBA Scientific Service Department.

## Water-Raman-peak signal-to-noise and emission calibration validation

This validation check examines the wavelength calibration of the CCD detector. It is an emission scan of the Raman-scatter band of water performed in right-angle mode.

The water sample should be research-quality, triple-distilled or de-ionized water.



**Note:** Avoid glass or acrylic cuvettes: they may exhibit UV fluorescence or filtering effects.

HPLC-grade (18-M $\Omega$  spec.) or equivalent water is suggested for the Raman scan. HORIBA Scientific recommends the Starna sealed water-Raman sample. Impure samples of water will cause elevated background levels as well as distorted spectra with (perhaps) some unwelcome peaks. Use a 4-mL quartz cuvette.



**Note:** The water Raman sample is available from Starna Cells, Inc., 5950 Traffic Way, Atascadero, CA 93422; phone: 800-228-4482; 805-466-8855; website is [www.starnacells.com](http://www.starnacells.com)

- 1 Insert the water sample into the sample compartment.  
With an automated sample changer, note the position number in which the sample cell is placed.
- 2 Close the lid of the sample chamber.
- 3 In the **Aqualog** main window, choose Collect:

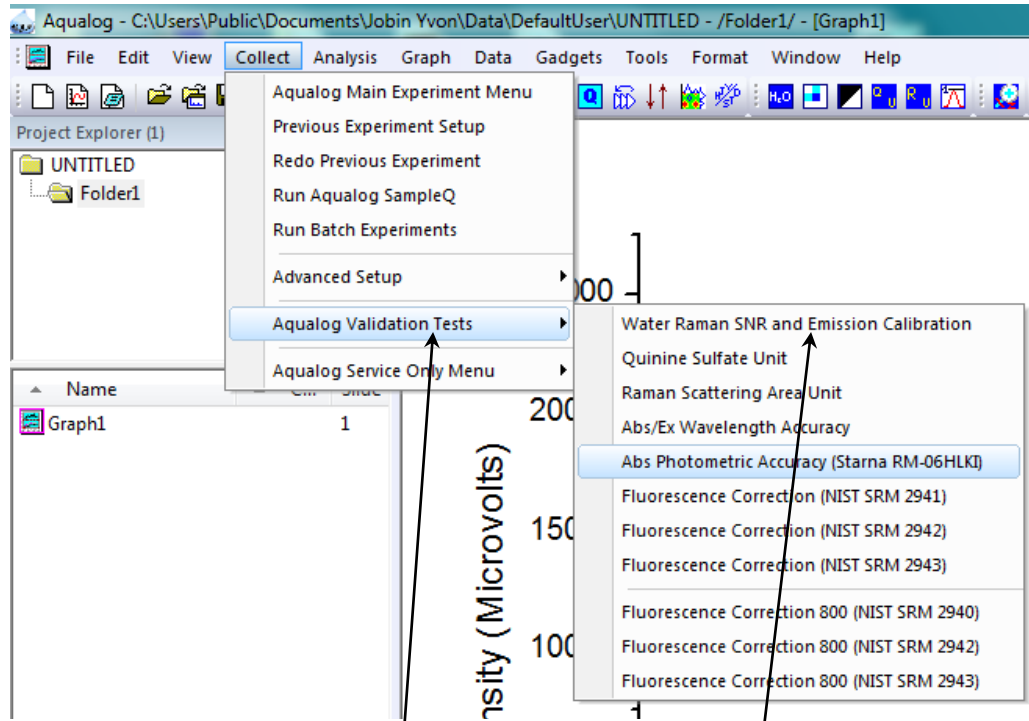

A drop-down menu appears.

**4 Choose Aqualog Validation Tests.**

Another drop-down menu appears.

**5 Choose Water Raman SNR and Emission Calibration.**

The validation experiment automatically loads with some of the fields grayed out:

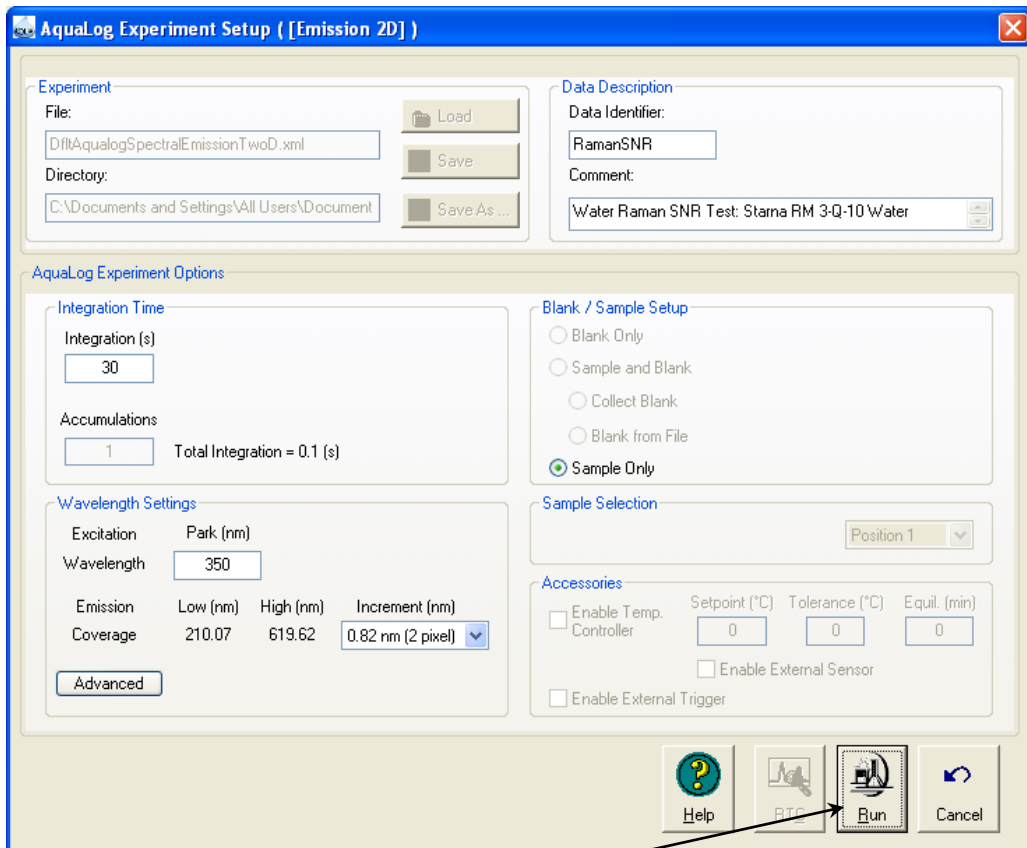

6 Click the Run button .

A message telling you to insert the sample appears.

7 Place the Starna water sample in the special sample holder, and mount the sample holder in the sample compartment.



- 8 Close the sample-compartment lid, and click the OK button.



The **Experiment Status** window opens.

The validation scan runs.

The **Project name** window appears:

- 9 Click the **Cancel** button.

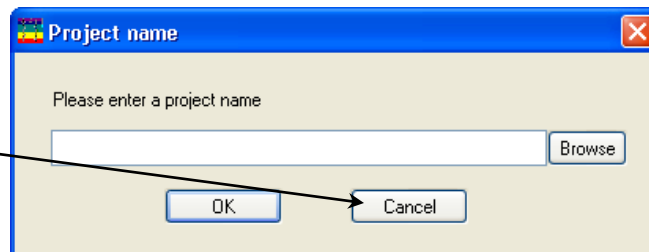

A plot of the validation test appears:

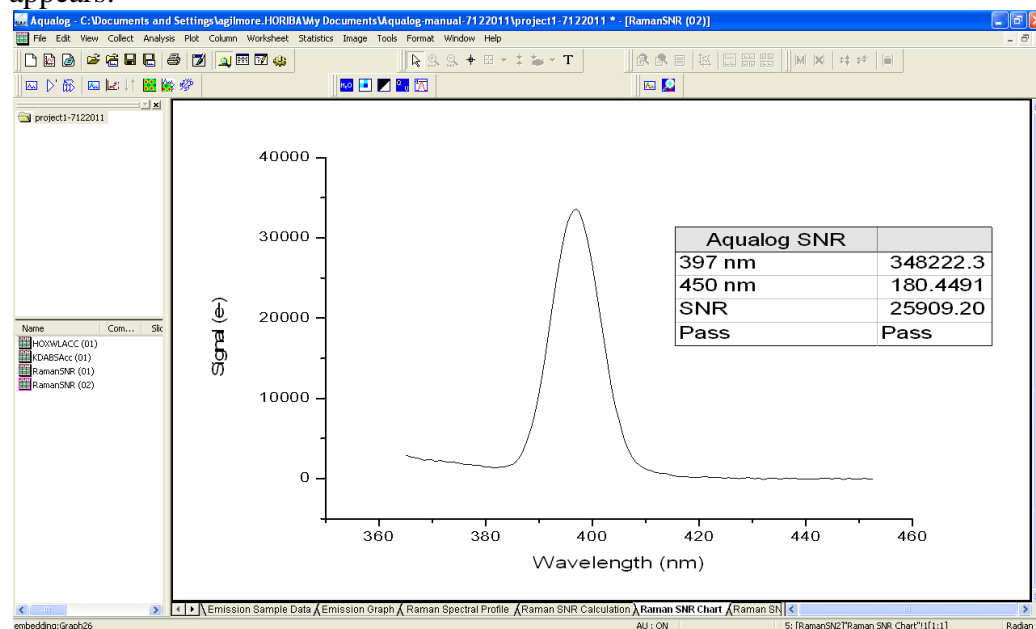

**Note:** Observed throughput (and hence peak intensity) is affected by lamp age and alignment, slit settings, and sample purity. As the xenon lamp ages, the throughput of the system will decline slowly. Therefore, low water-Raman peak intensity may indicate a need to replace the xenon lamp.

- 10 If the test shows a “Pass” value, continue to the next test.

If the plot displays “fail”, please call the HORIBA Scientific Service Department.



# Fluorescence correction validation with NIST SRM 2941 sample

This validation check examines the accuracy of the fluorescence correction file of the Aqualog<sup>®</sup>. Use the fluorescence standards (SRM 2941, SRM 2942, and SRM 2943) available from NIST.

 **Note:** Fluorescence standards (SRM 2941, SRM 2942, and SRM 2943) are available from National Institute for Standards and Technology (NIST), phone: 301-975-2200; website is [www.nist.gov](http://www.nist.gov)

1 In the Aqualog main window, choose Collect.

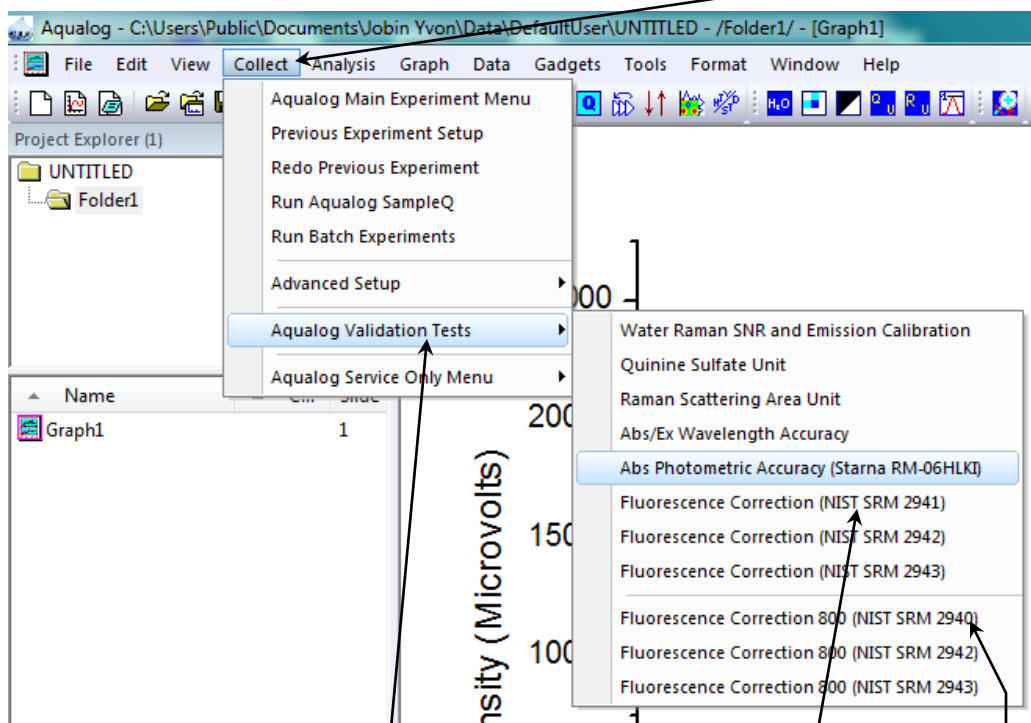

A drop-down menu appears.

2 Choose Aqualog Validation Tests.

Another drop-down menu appears.

3 Choose Fluorescence Correction (NIST SRM 2941).

 **Note:** If you have an Aqualog<sup>®</sup>-800, choose Fluorescence Correction 800 (NIST SRM 2940) instead.

The validation experiment automatically loads with some of the fields grayed out:

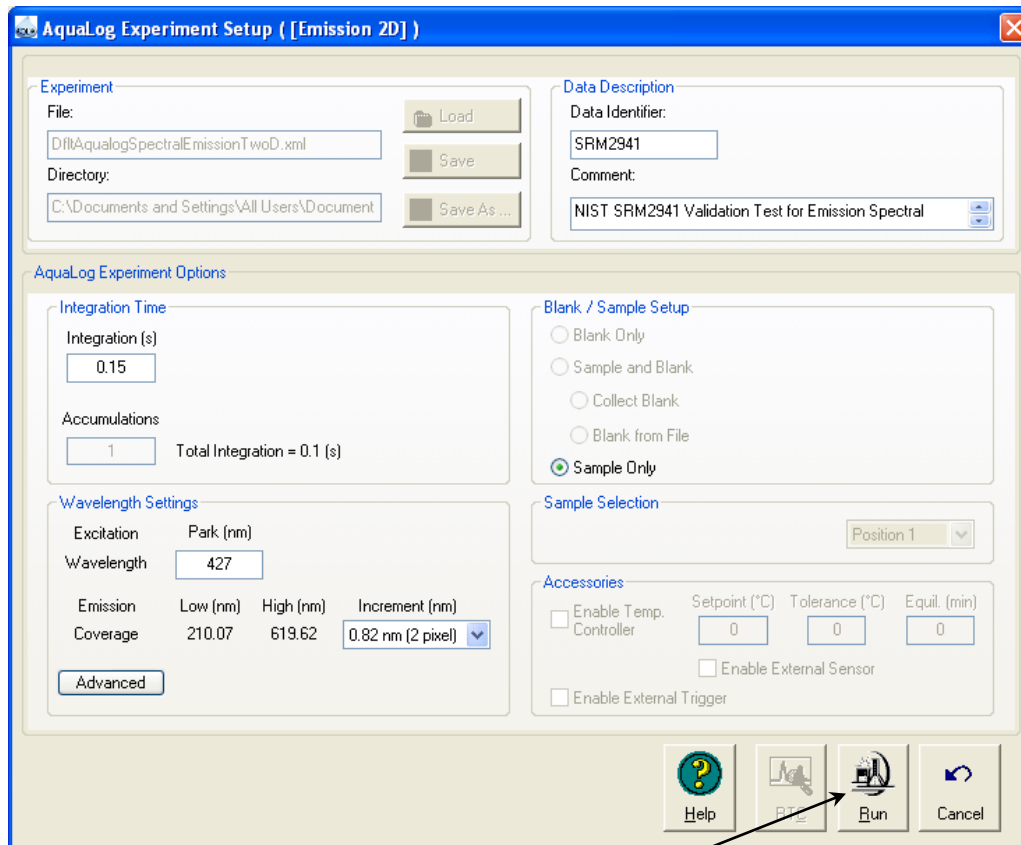

- 4 Click the Run button .

A message telling you to insert the blank appears:

- 5 Insert the 2941 standard with the frosted side toward the front of the instrument (for fluorescence), and the clear sides toward the left and right of the instrument (for absorption).



**Note:** If you have an Aqualog®-800, insert the NIST SRM 2940 instead.

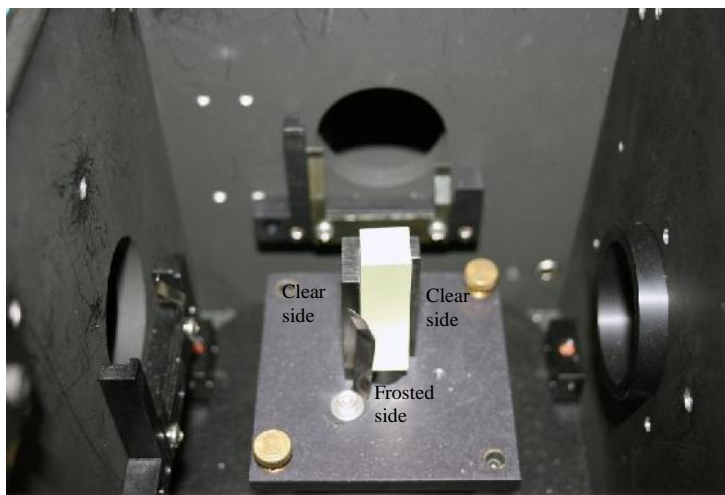

6 Close the sample-compartment lid, and click the OK button.

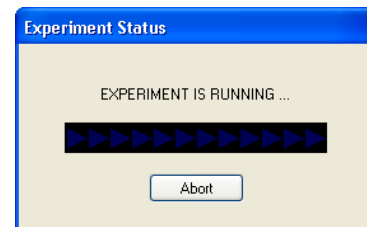

The **Experiment Status** window opens.  
The validation scan runs.  
The **Project name** window appears:

7 Click the **Cancel** button.

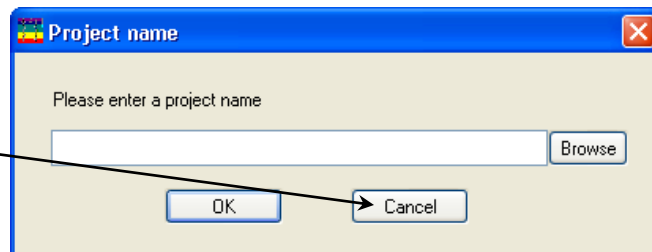

A plot of the validation test appears:

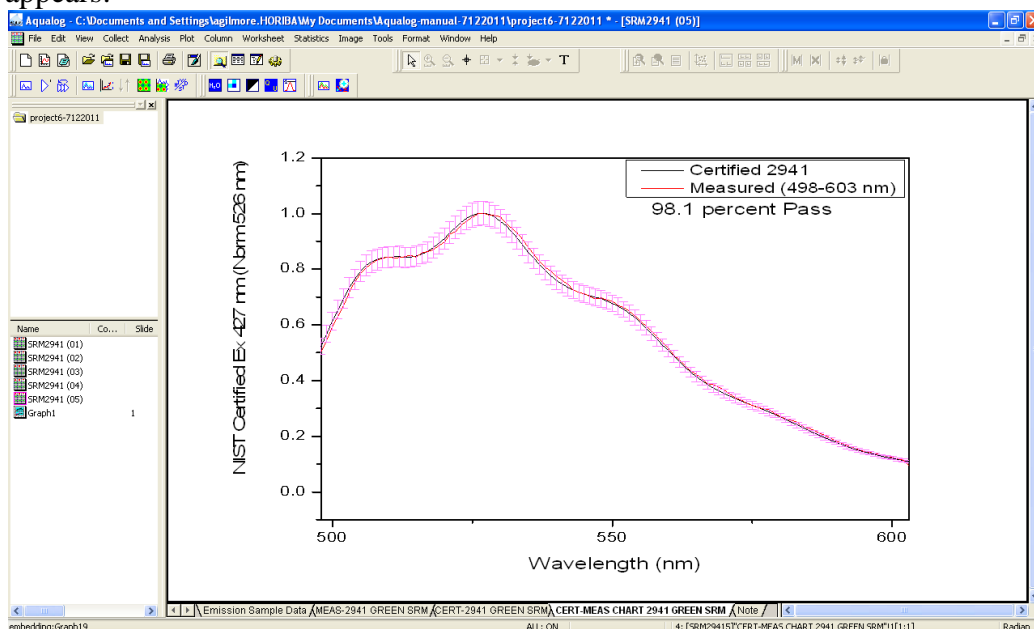

8 If the test shows a “Pass” value, continue to the next test.

If the plot displays “fail”, please call the HORIBA Scientific Service Department.

# Fluorescence correction validation with NIST SRM 2942 sample

This validation check examines the accuracy of the fluorescence correction file of the Aqualog®.

1 In the **Aqualog** main window, choose **Collect**.

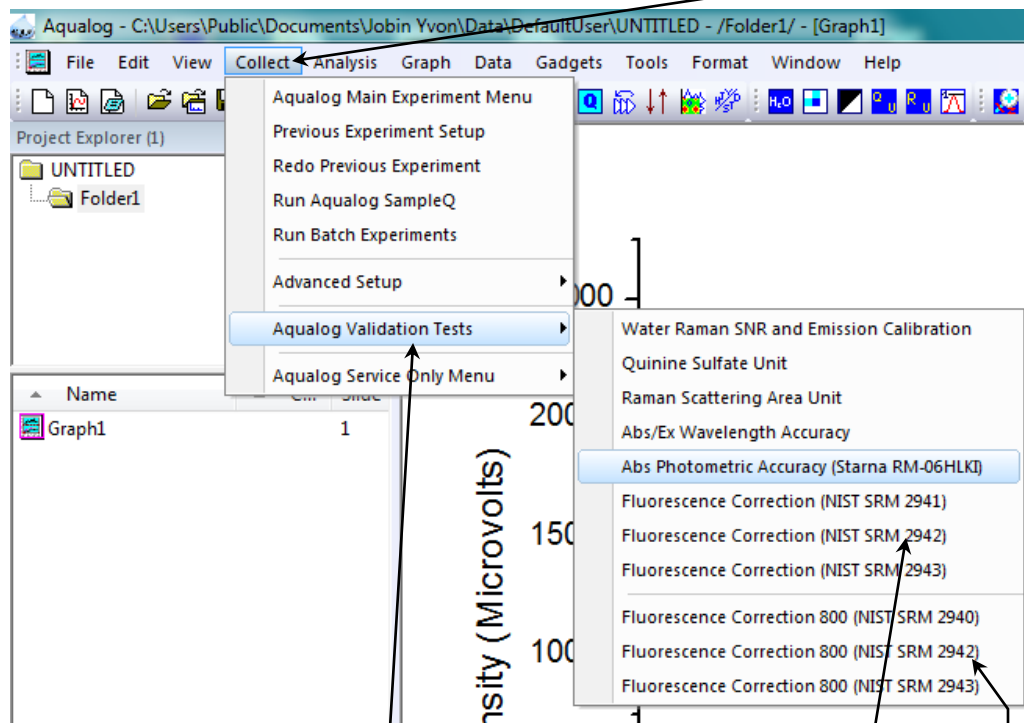

A drop-down menu appears.

2 Choose **Aqualog Validation Tests**.

Another drop-down menu appears.

3 Choose **Fluorescence Correction (NIST SRM 2942)**.



**Note:** If you have an Aqualog®-800, choose **Fluorescence Correction 800 (NIST SRM 2942)** instead.

The validation experiment automatically loads with some of the fields grayed out:

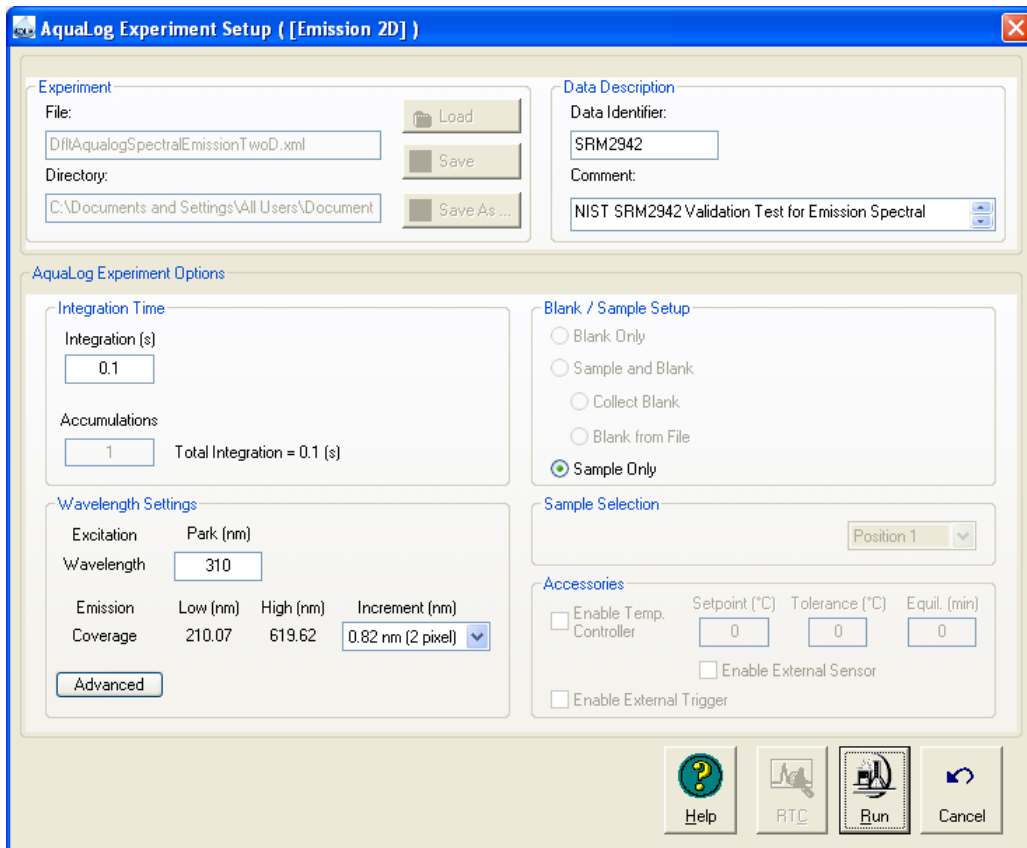

- 4 Click the Run button .

A message telling you to insert the blank appears:

- 5 Insert the 2942 standard with the frosted side toward the front of the instrument (for fluorescence), and the clear sides toward the left and right of the instrument (for absorption).

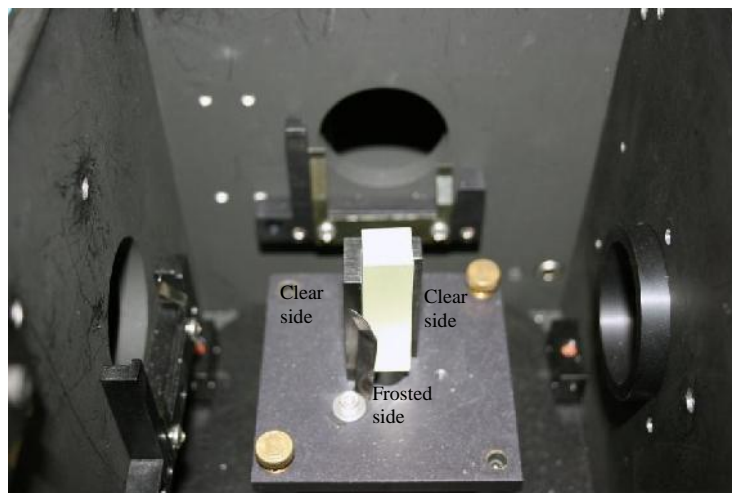

6 Close the sample-compartment lid, and click the OK button.



The **Experiment Status** window opens.

The validation scan runs.

The **Project name** window appears:

7 Click the **Cancel** button.

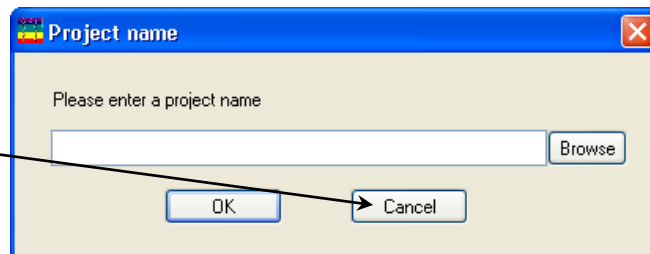

A plot of the validation test appears:

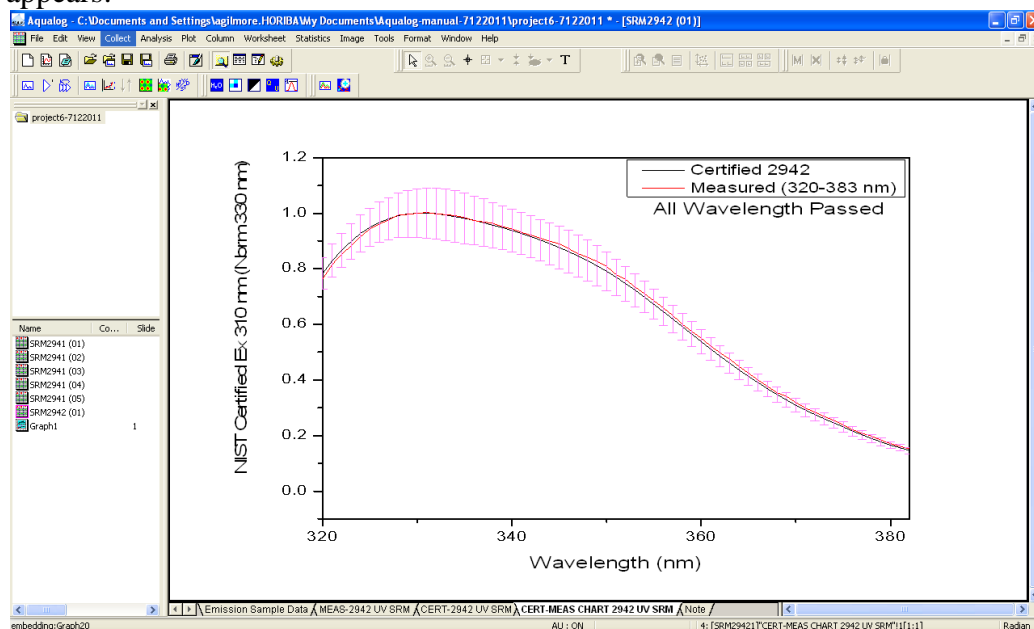

8 If the test shows a “Passed” value, continue to the next test.

If the plot displays “fail”, please call the HORIBA Scientific Service Department.

# Fluorescence correction validation with NIST SRM 2943 sample

This validation check examines the accuracy of the fluorescence correction file of the Aqualog®.

**1** In the **Aqualog** main window, choose **Collect**.

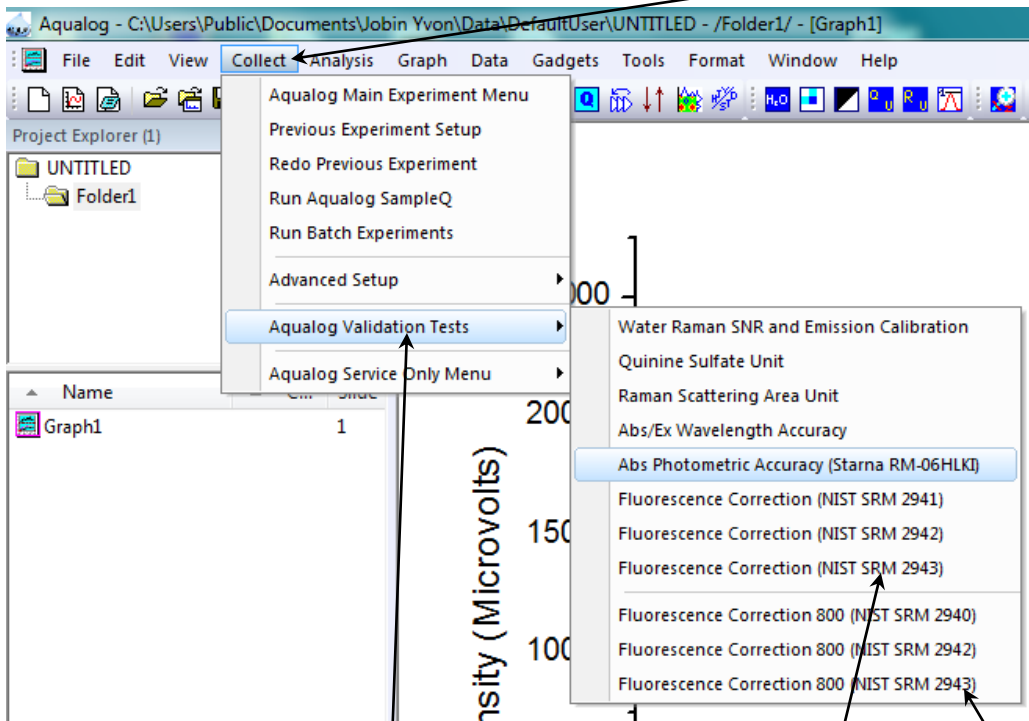

A drop-down menu appears.

**2** Choose **Aqualog Validation Tests**.

Another drop-down menu appears.

**3** Choose **Fluorescence Correction (NIST SRM 2943)**.



**Note:** If you have an Aqualog®-800, choose Fluorescence Correction 800 (NIST SRM 2943) instead.

The validation experiment automatically loads with some of the fields grayed out:

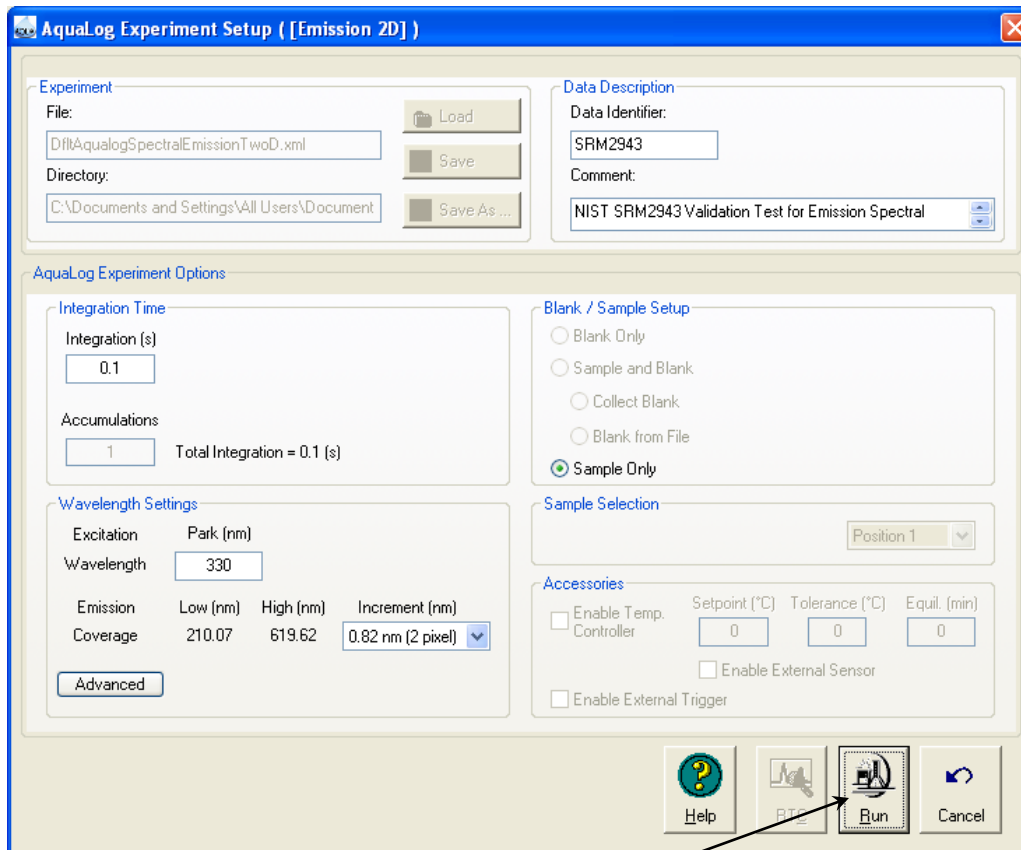

4 Click the Run button .

A message telling you to insert the blank appears:

5 Insert the 2943 standard with the frosted side toward the front of the instrument (for fluorescence), and the clear sides toward the left and right of the instrument (for absorption).

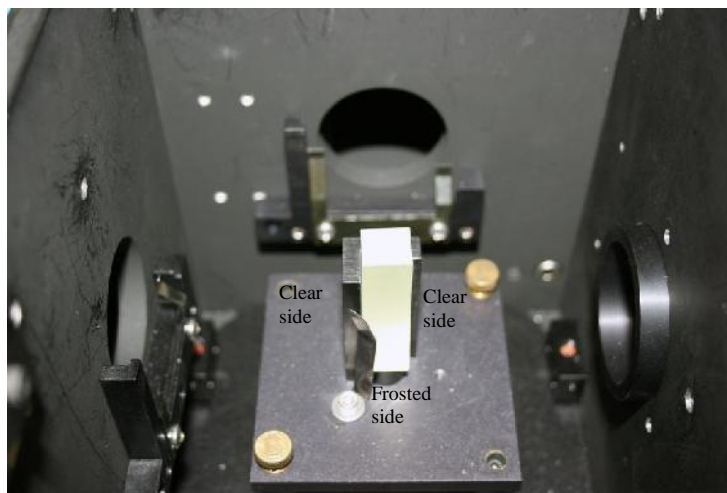



6 Close the sample-compartment lid, and click the OK button.

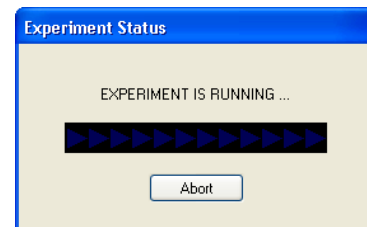

The **Experiment Status** window opens.

The validation scan runs.

The **Project name** window appears:

7 Click the **Cancel** button.

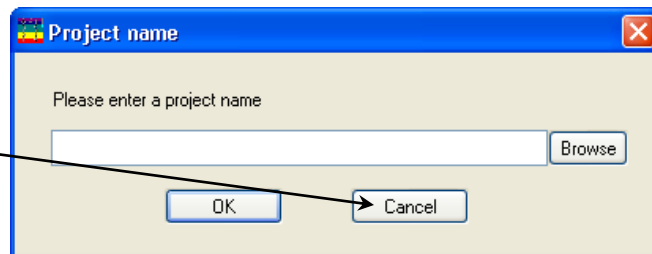

A plot of the validation test appears:

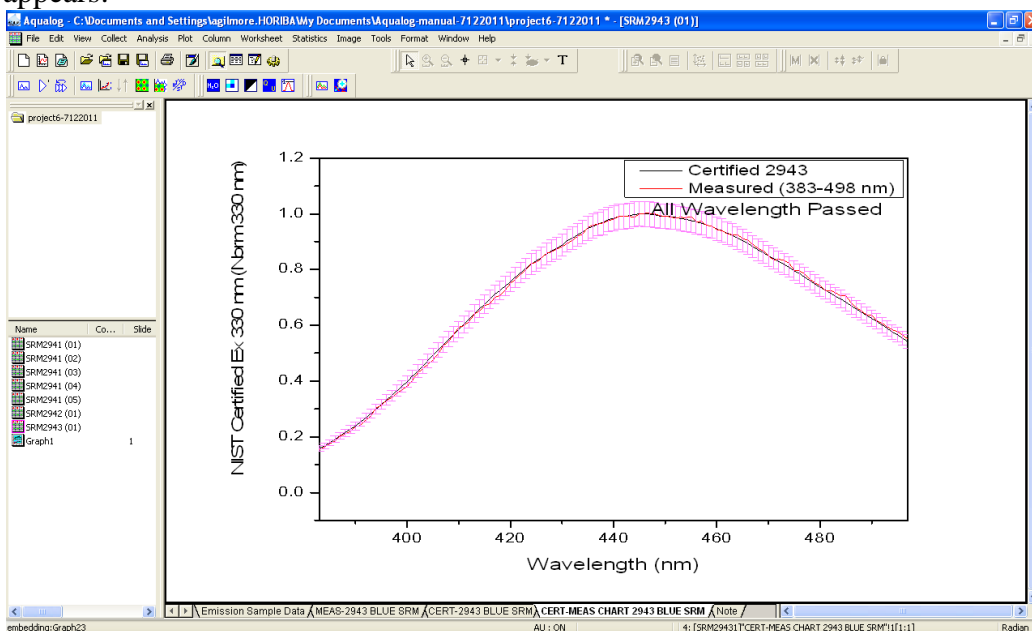

8 If the test shows a “Passed” value, the Aqualog<sup>®</sup> is calibrated properly.

If the plot displays “fail”, please call the HORIBA Scientific Service Department.

# Calculation of water-Raman signal-to-noise ratio

## Introduction

The water-Raman test is a good measure of relative sensitivity between different instruments, if the experimental conditions used to compare the systems are the same. Unfortunately, there are different ways of handling the data, all of which are valid but which will give quite different values. Therefore, it is important not only to know how the water-Raman  $S/N$  values are measured, but also how the data were treated. The water-Raman  $S/N$  test method combines a value for system sensitivity (a signal) with a value for system noise (no signal) to show the overall performance of the instrument.

## Definitions

At HORIBA Scientific, we define the  $S/N$  ratio of the Aqualog<sup>®</sup> as the difference of peak and background signals, divided by the root-mean-square of the background signal:

$$\frac{S}{N} = \frac{S_{peak} - S_{background}}{N_{rms,background}} \quad \text{Aqualog}^{\text{®}} \text{ } S/N \text{ method}$$

Explicitly, the peak signal ( $S_{peak}$ ) is evaluated for a 5 nm interval centered at 397 nm, the background ( $S_{background}$ ) is evaluated for a 5 nm integral centered at 450 nm, and the RMS noise of the background ( $N_{rms}$ ) is evaluated for the 5 nm integral centered at 450 nm. The experimental conditions include monitoring a 30 s integration time of the dark and sample CCD signals; the former subtracted from the latter to emulate standard experimental conditions and remove any fixed-pattern noise on the CCD not related to the sample's actual light scattering. The CCD-bin interval is 0.82 nm/pixel bin. The signal is interpolated to 0.5 nm interval steps from 365–452.5 nm. The measurement is performed at room temperature (25°C).

## Notes on validation

- The lamp is rated for 1200–1500 h, but if the Raman intensity starts to drop below 40%, you may wish to change the lamp sooner.
- The Aqualog<sup>®</sup> automatically records the lamp hours, and reminds you to change the lamp at 1000 hours.

# 5: Data-Acquisition

## Introduction to Aqualog<sup>®</sup> software

This chapter presents an introduction to special buttons used in the Aqualog<sup>®</sup> software to record and present data with the Aqualog<sup>®</sup>. These buttons, located in Aqualog<sup>®</sup>'s main window, are:

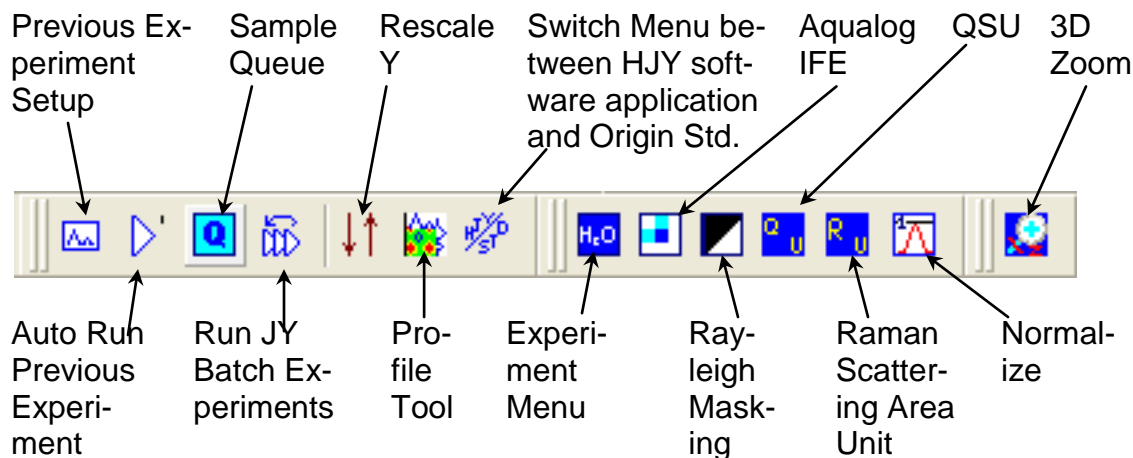

For a detailed description of these Aqualog<sup>®</sup> routines, see the *Aqualog User's Guide* and on-line help.

In addition, methods for determining best excitation and emission wavelengths are presented, in case these wavelengths are unknown for the sample.

# Experiment Menu button

## Introduction

The Experiment Menu button chooses an overall type of experiment to run, such as an emission scan, an absorbance scan, kinetics run, etc., based on the instrument and connected accessories, such as a temperature bath, integrating sphere, etc. Only those scans that can be run using the available hardware configuration are active; scans that cannot be taken are grayed out.

Calibration scans for the Aqualog<sup>®</sup> use default parameters:

- Excitation monochromator: Spectra/Excitation scan
- Emission monochromator: Spectra/Emission scan

## Blank files

Blank files are recorded as \*.blank. When scanning, you can choose to record only a blank, record only the sample, record a sample and a blank, or process a sample from a previously-saved blank.

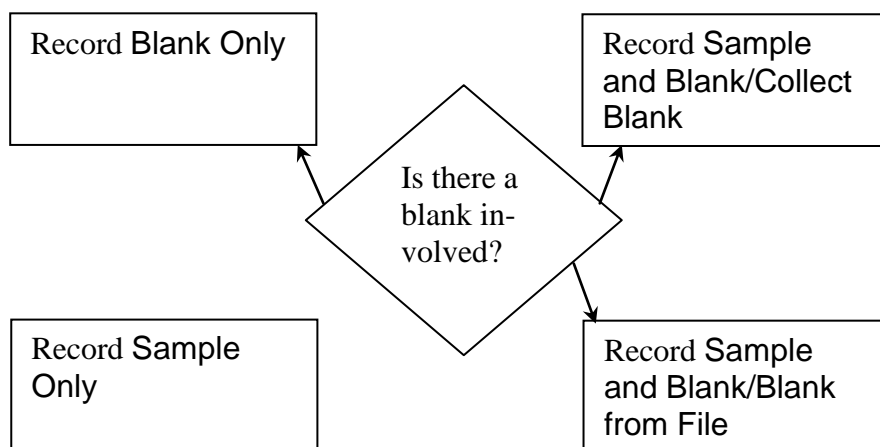

## Types of experiments

Following are types of Aqualog<sup>®</sup> experiments available in the **Aqualog Main Experiment Menu**:

**Spectra**

Absorbance  
2D emission

**Kinetics**

Absorbance  
Emission  
Emission + absorbance simultaneously

**3D**

Excitation-emission matrix (EEM)  
EEM + absorbance simultaneously

**Single-point**

Method

- 1 To choose an experiment type, click the Experiment Menu button :

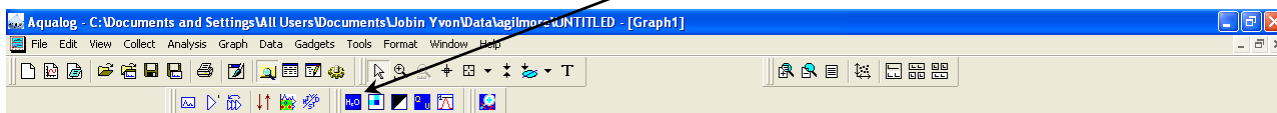

The **Aqualog Main Experiment Menu** appears:

- 2 Choose an experiment type.



*Note: Certain scan types are not allowed with the Aqualog®, and are grayed out.*

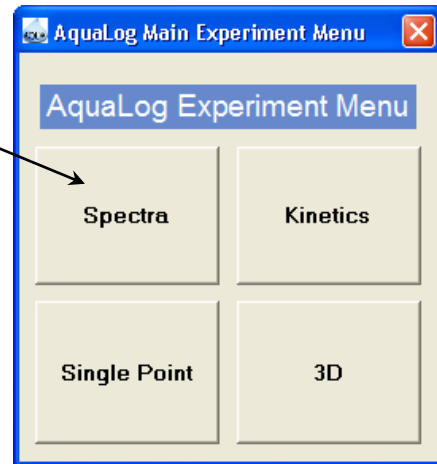

The **Aqualog Experiment Type** window appears (if there are subtypes of experiment):

- 3 Choose a subtype of experiment, and click the Next >> button.

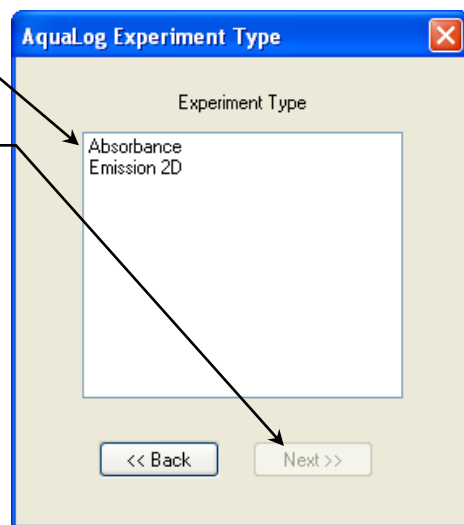

The **Aqualog Experiment Setup** window appears, customized for that experiment:

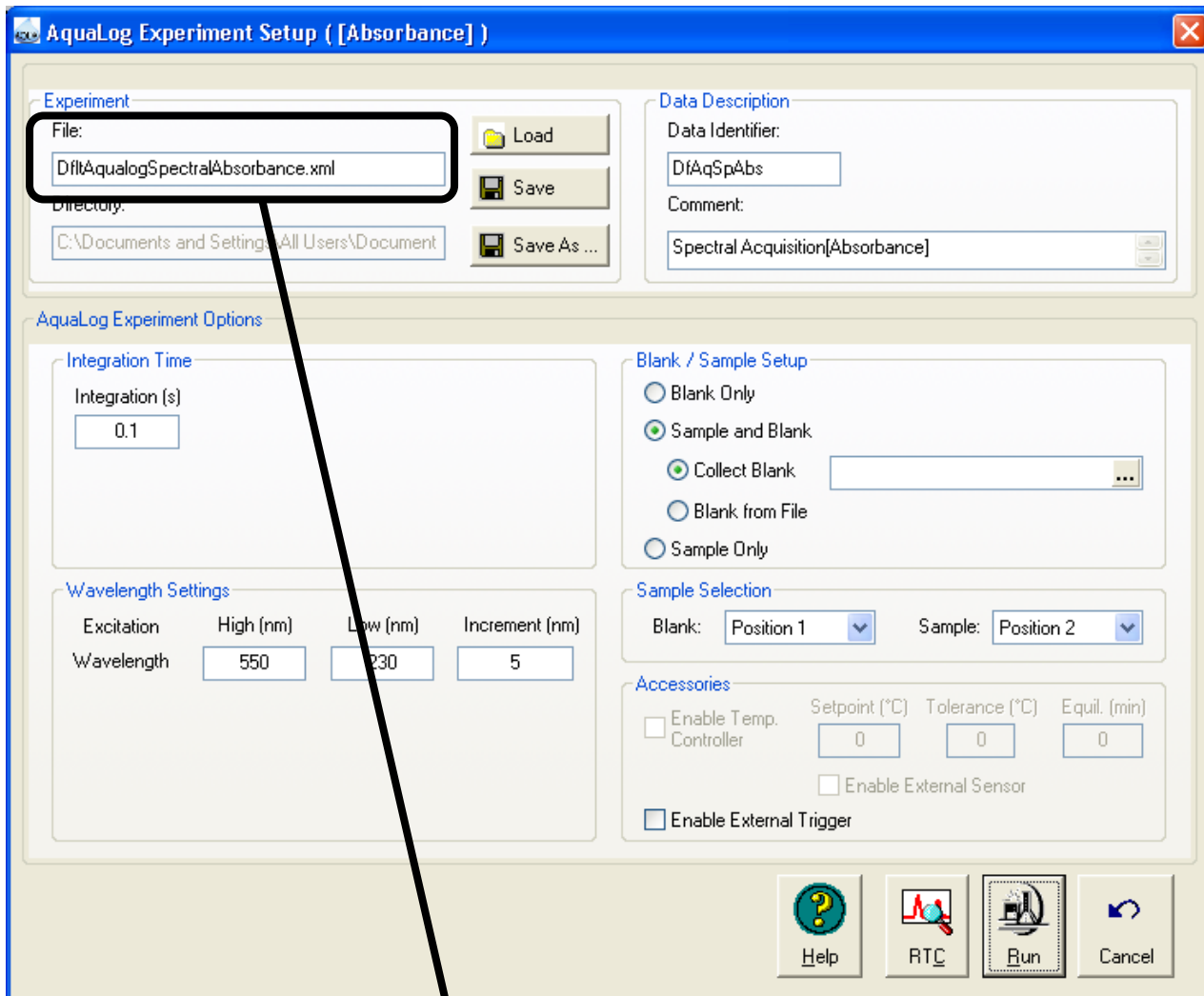

- 4 Click the File field, and enter a new file name or select a previously saved file.
- 5 In the Aqualog Experiment Options area, verify that experimental parameters are correct.
- 6 Insert the sample into the sample compartment, and close the sample compartment's cover.



- 7 Click the Run button.

If you do not have an automatic sample-changer, a prompt appears to insert the blank or sample.

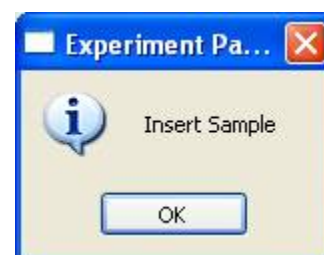

- 8 Click the OK button when you have inserted the blank or sample and closed the cover.

The collected spectrum is displayed on the **Intermediate Display** screen. After all data are recorded, the **Intermediate Display** vanishes. For a new project, the **Project Name** window appears:

- 9 Enter a name for the entire project, or browse for an existing project name with the Browse button, then click the OK button.

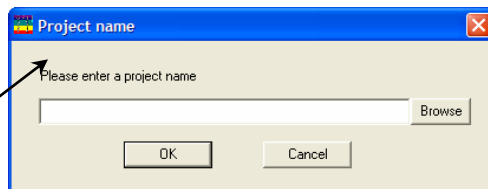

All data are moved to Origin<sup>®</sup>'s graph window for post-processing.

# Previous Experiment Setup button

The Previous Experiment Setup button resets the experiment to the previous experiment used, with minor modifications to the hardware possible.

- 1 After an experiment is loaded, click the Previous Experiment Setup button  in the main toolbar:



**Note:** The Previous Experiment Setup button is active only after an experiment already has been loaded.

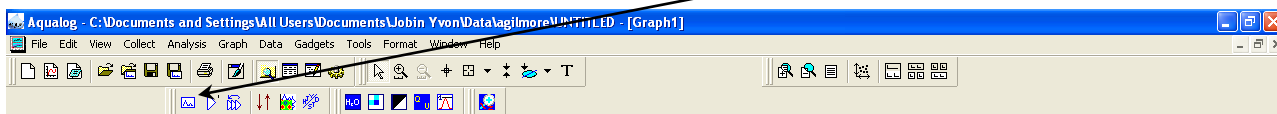

The last experiment used or loaded appears in the **Aqualog Experiment Setup** window:

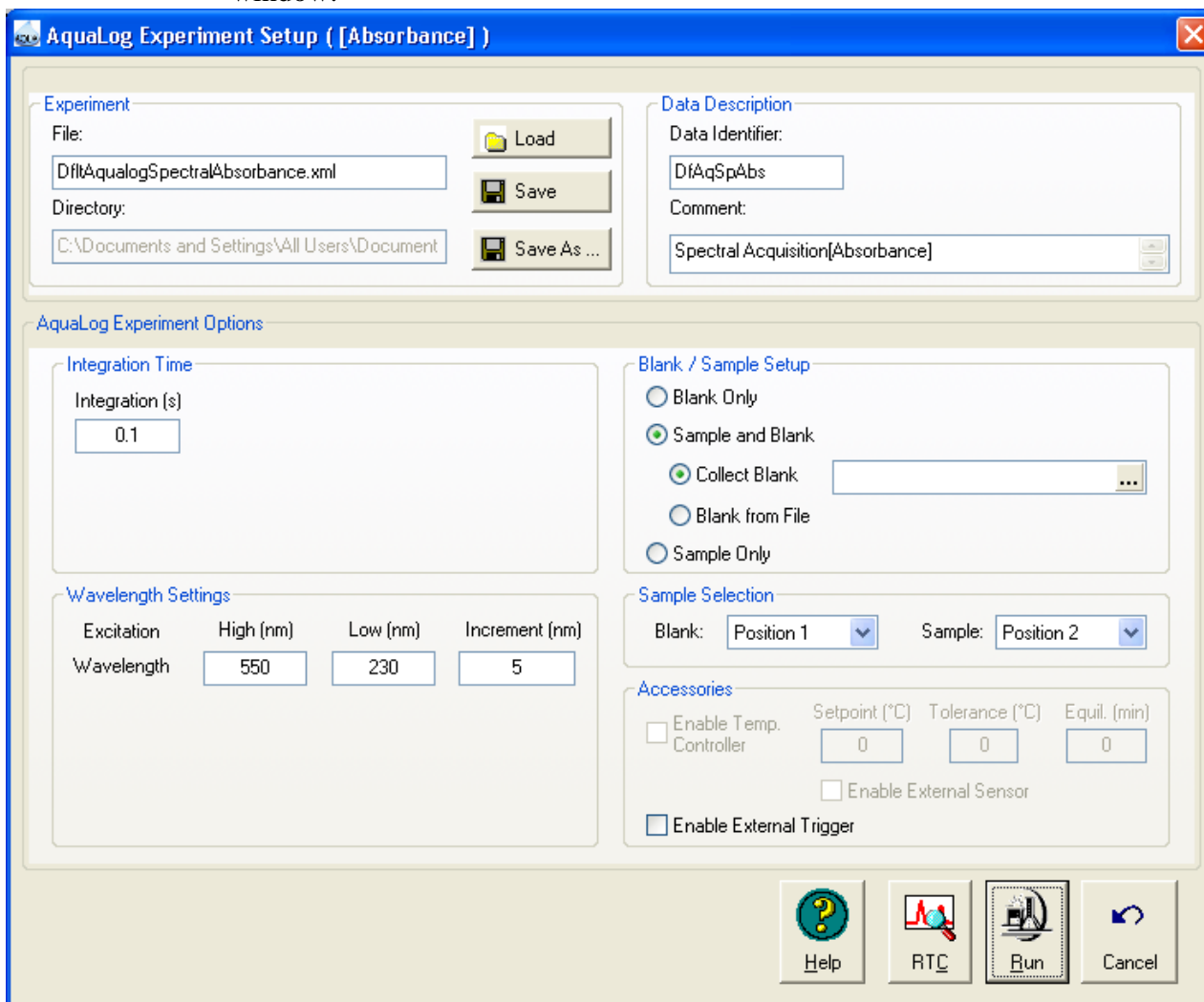

- 2 Modify the experiment's parameters as required.



3 Click the Run button  to run the experiment.

# Auto Run Previous Experiment button

The Auto Run Previous Experiment button reruns the last experiment loaded without modifications.



**Note:** The Auto Run Previous Experiment button is active only after an experiment has already been loaded and run.

## 1 Click the Auto Run Previous Experiment button

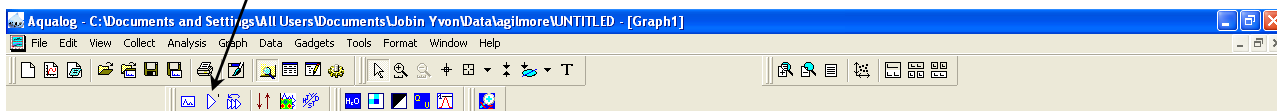

The **Intermediate Display** appears, and the experiment starts:

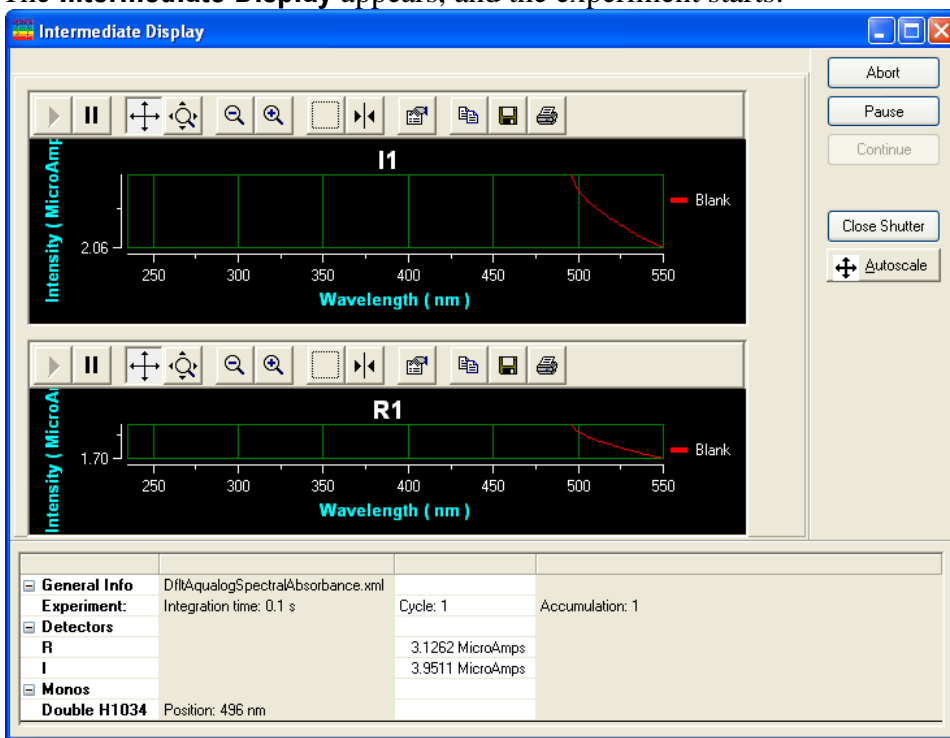

When the experiment is complete, the data appear in a new Origin<sup>®</sup> graph window:

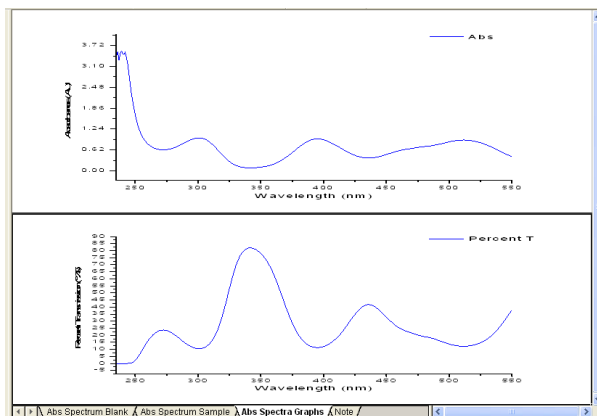

# Aqualog IFE button

The Aqualog IFE button processes data and accounts for the inner-filter effect.



**Note:** This button only works with waterfall plots.

- 1 With an active set of raw data open, click the Aqualog IFE button  in the main toolbar.

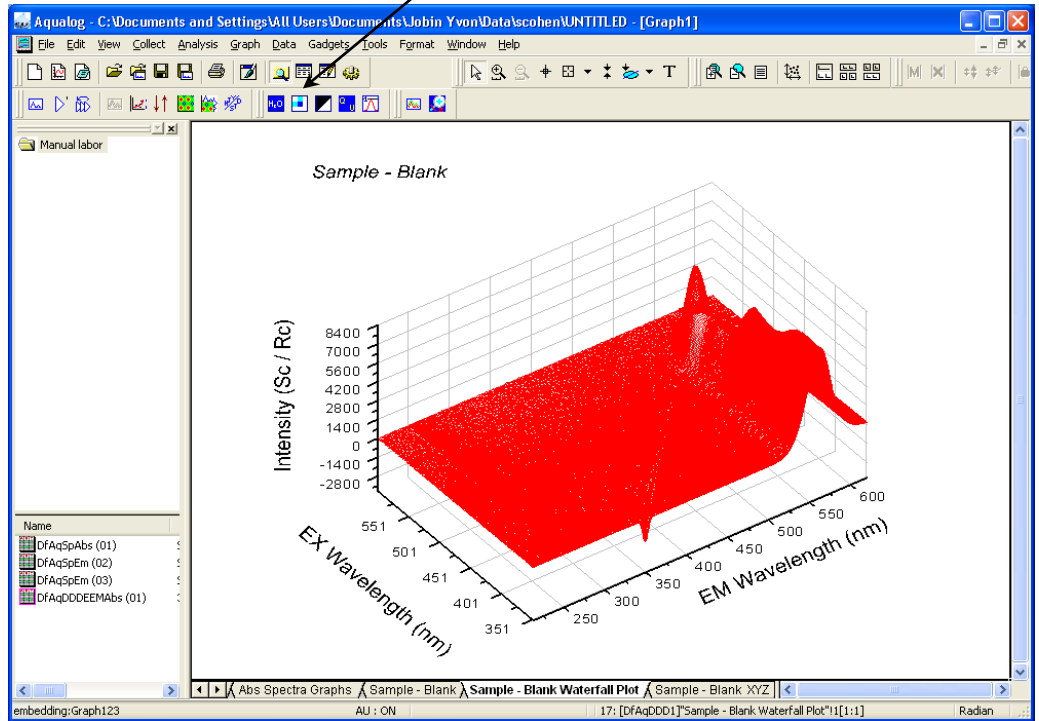

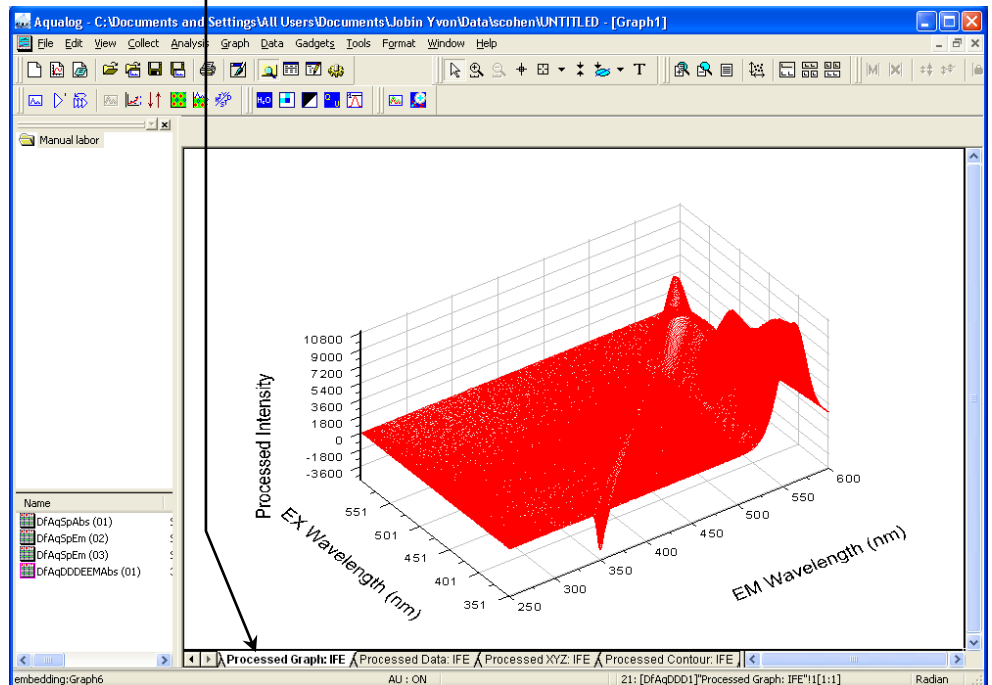

The host computer compensates for the inner-filter effect. This calculation may take some time. A new tab called Processed Graph: IFE appears in the graph area:



# Rayleigh Masking button

The Rayleigh Masking button automatically masks Rayleigh scattering lines that appear in the data.

 **Note:** This button only works with waterfall plots.

1 With an active set of raw data open, click the Rayleigh Masking button  in the main toolbar.

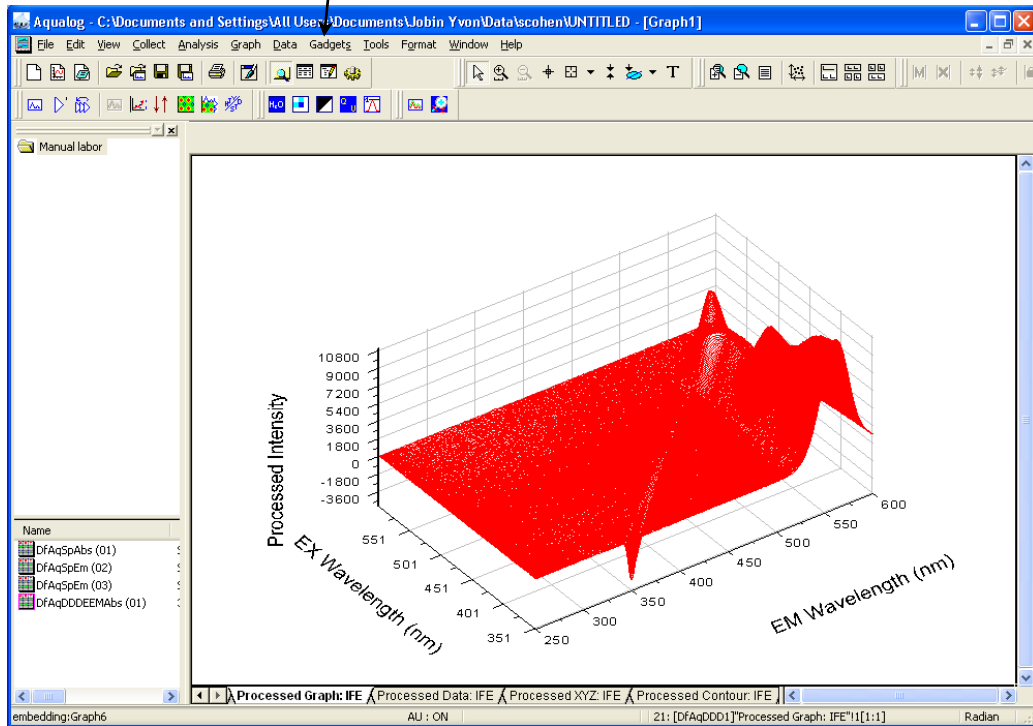

The **JY Rayleigh Masking User Input** window appears.

2 Click the **OK** button.

The host computer compensates for the inner-filter effect. This calculation may take some time.

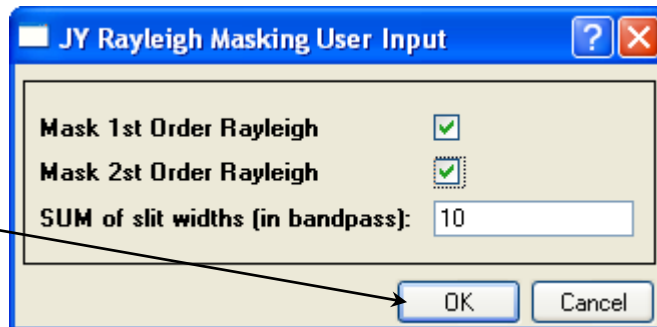

A new tab called **Processed Graph: RM** appears in the graph area:

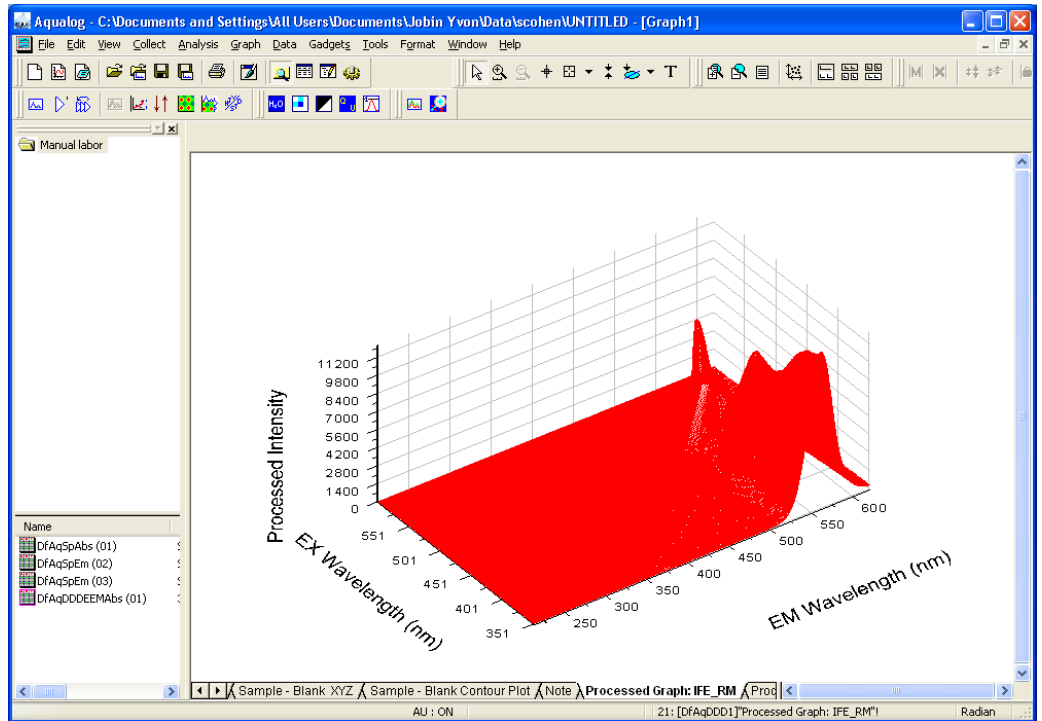

# Normalize button

The Normalize button automatically normalizes the active data to intensities between 0 and 1.



**Note:** HORIBA Scientific recommends that you normalize your data as the last step in processing. Perform inner-filter effect compensation and Rayleigh masking before normalization.

*This button only works with waterfall plots.*

- 1 With an active set of data open, click the Normalize button  in the main toolbar.

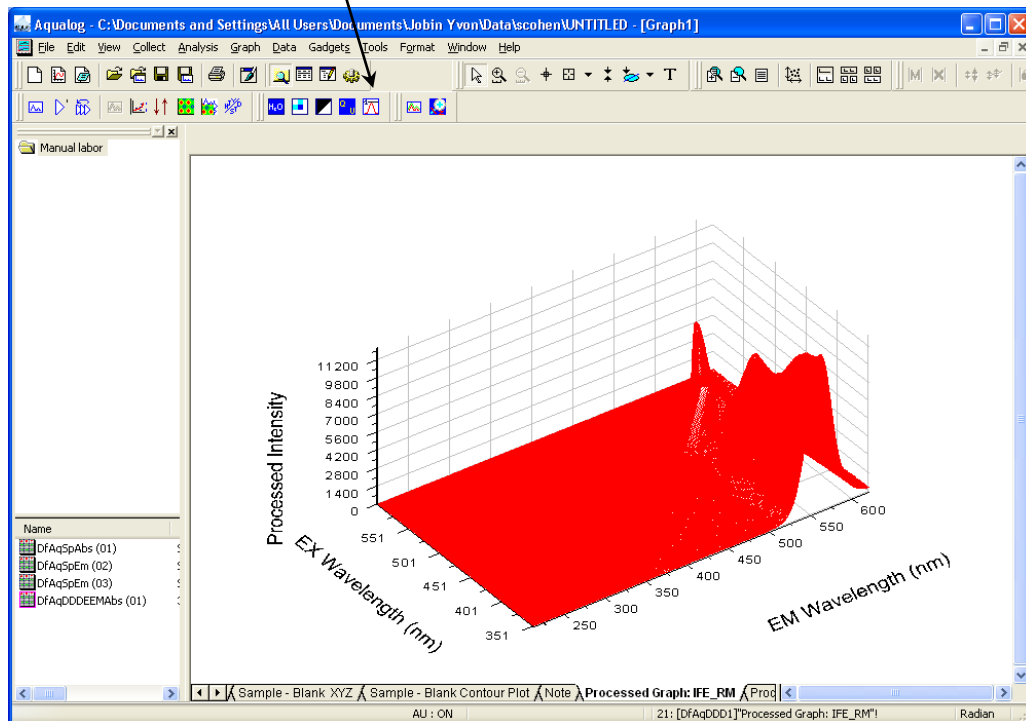

The HJY\_normalize window appears.

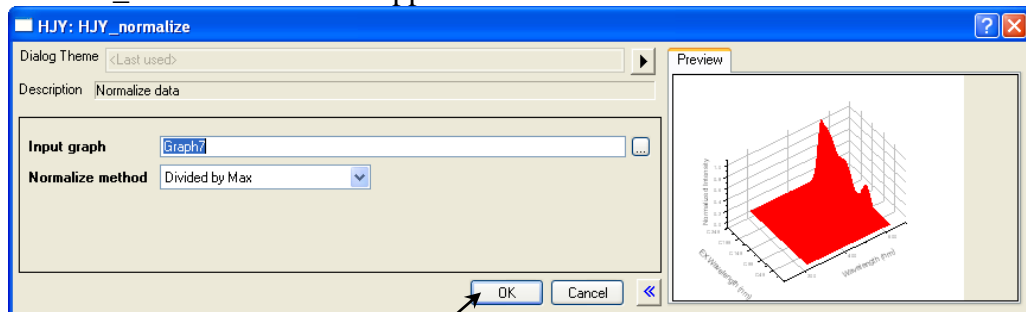

- 2 Click the OK button.

The host computer compensates for the inner-filter effect. This calculation may take some time.

A new tab called Processed Graph: NRM appears in the graph area:

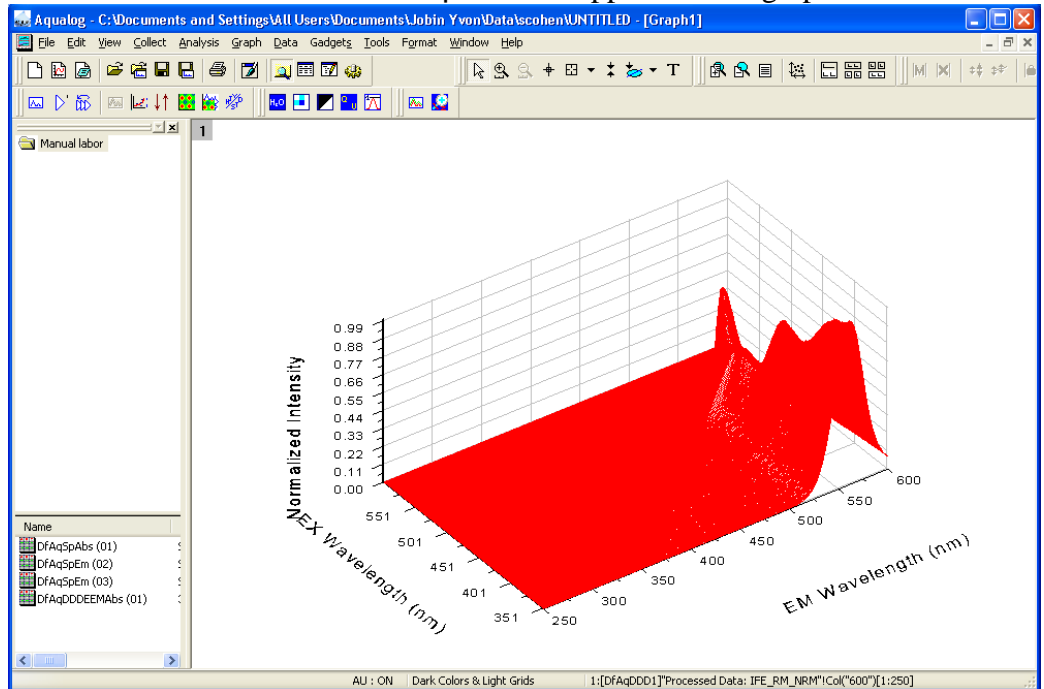

You can also examine a contour plot of the data:

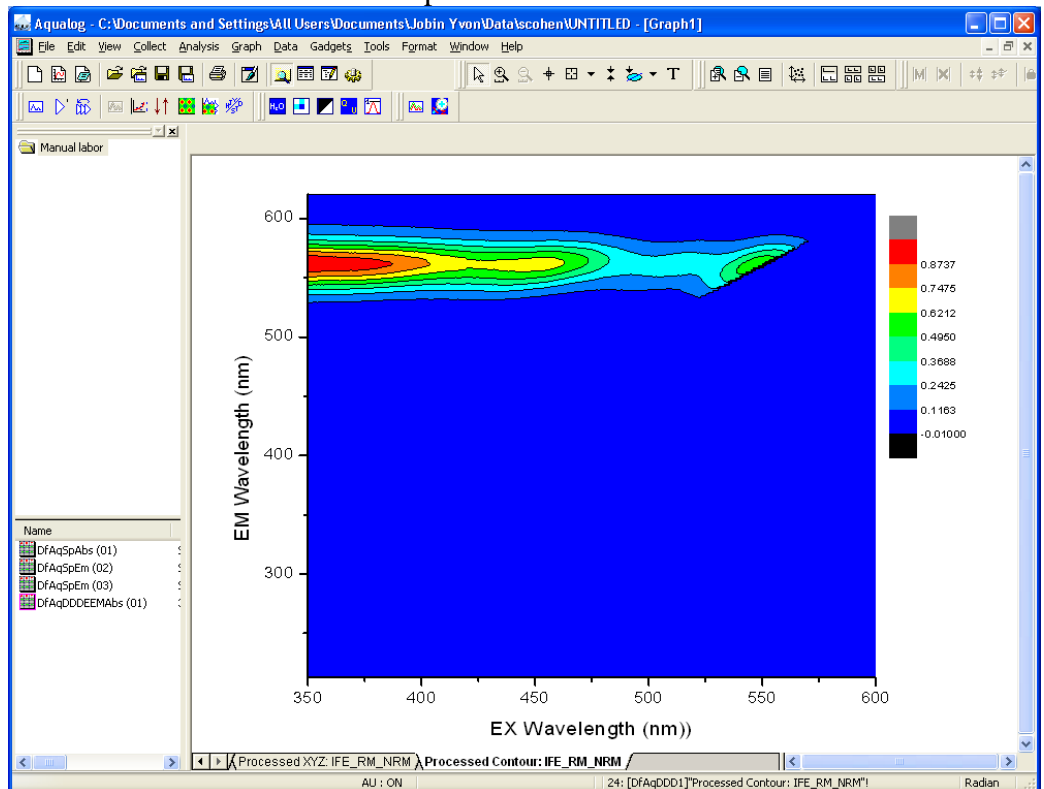

The contour plot may be easier to understand visually.

# Run JY Batch Experiments button

The Run JY Batch Experiments button runs a series of automated experiments, including adjustable repeats and delays between experiments.

## 1 Click the Run JY Batch Experiments button .

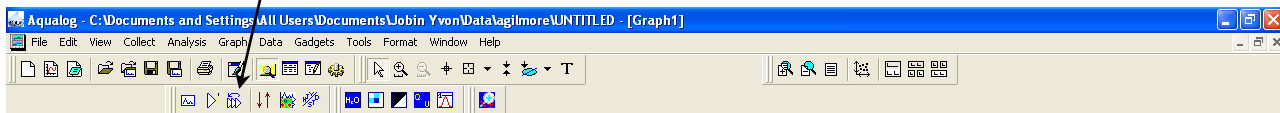

The **Setup batch experiments** window appears.

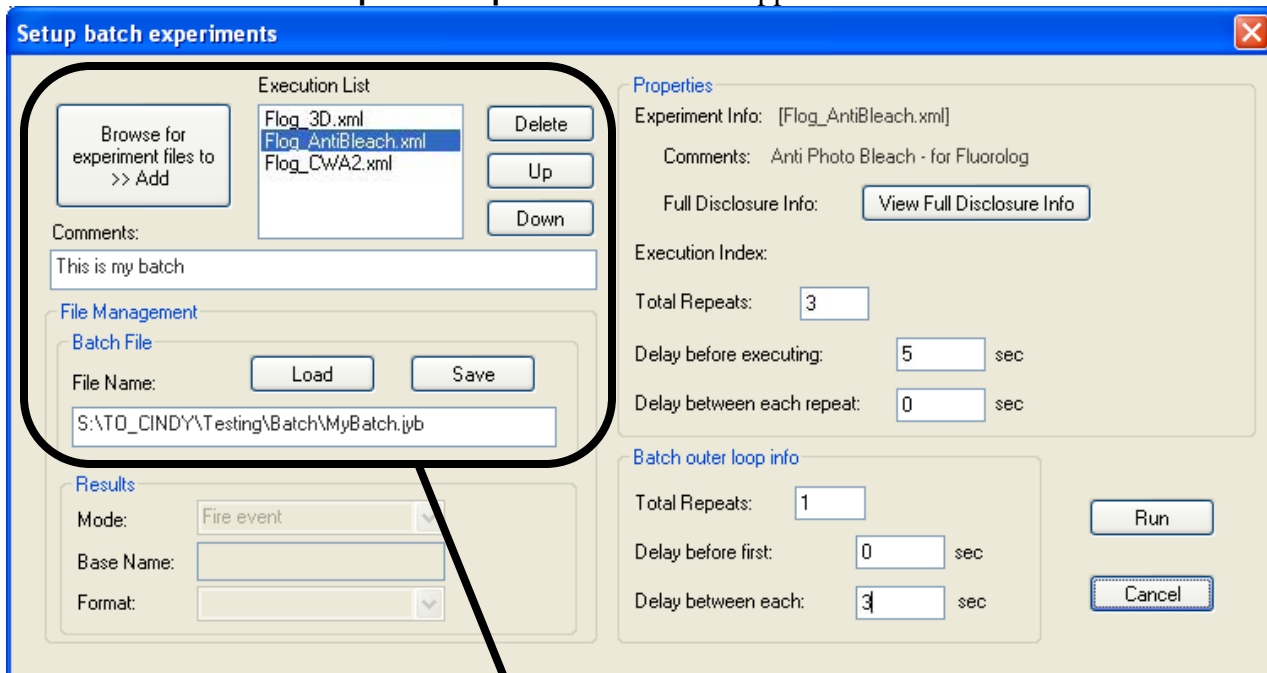

## 2 Get the experiment files to create a batch job, or load a previous batch job.

- a Load a previously created batch job using the Load button, or browse for experiment files (.xml format) using the Browse for experiment files to >> Add button.
- b Add each desired experiment file to the Execution List.
- c Reorder or remove the files as necessary using the Delete button, the Up button, and the Down button.
- d Add comments about the batch file in the Comments field.
- e Save the new batch job in the correct path, in the File Name field, and click the Save button.  
The file is saved in a .jyb format.

## 3 Set up each experiment in the batch job.



- a Select an experiment from the Execution List.
- b In the Total Repeats: field, enter the number of times that experiment should be repeated.

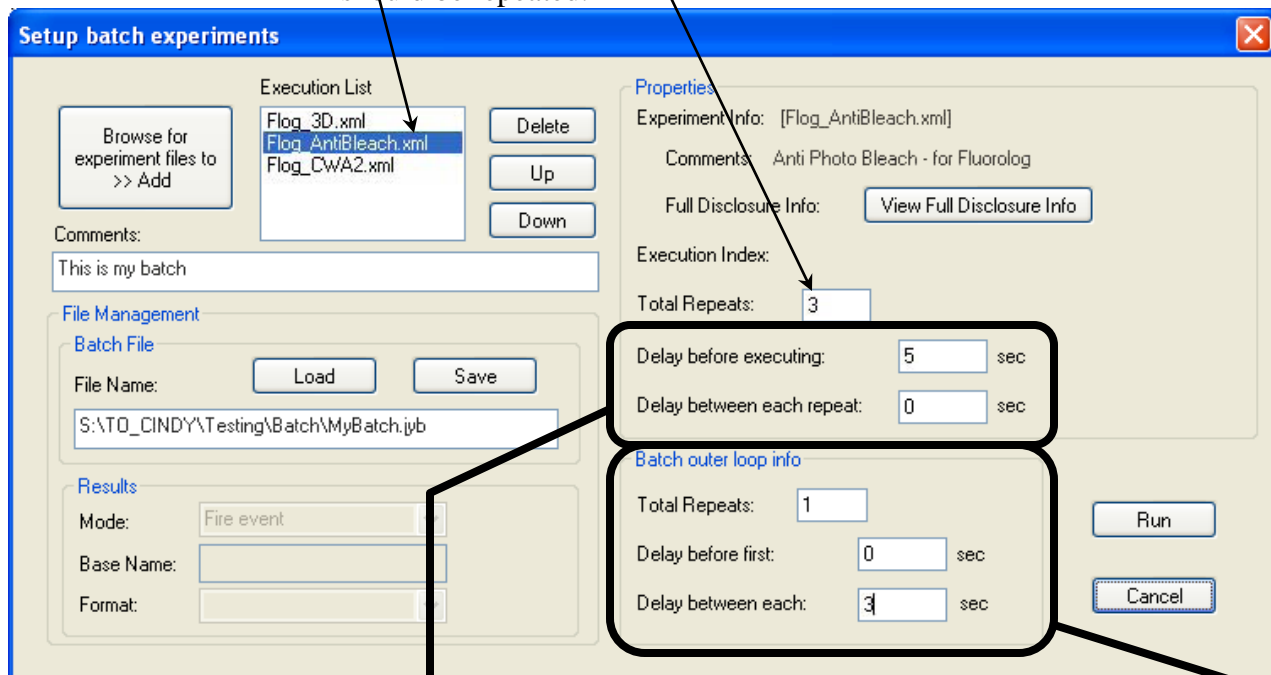

- c In the Delay before executing: field, enter the number of seconds to wait before executing.
- d In the Delay between each repeat list: field, enter the number of seconds to wait before repeating the experiment.

#### 4 Set up an outer loop in the batch job, if desired.

- a In the Total Repeats: field, enter the number of times to run the batch job.
- b In the Delay before first: field, enter the number of seconds to wait before starting the batch job.
- c In the Delay between each: field, enter the number of seconds to wait before rerunning the batch job.

#### 5 Click the Run button to start the batch job.

The batch job executes.

# Switch menu between HJY Software Application and Origin Pro button

The Switch menu between HJY Software Application and Origin Pro. button switches the menus at the top of the main **Aqualog** window between Aqualog<sup>®</sup> and Origin<sup>®</sup> functions. This allows the user to tap the power more fully of Origin<sup>®</sup> software.

- 1 Click the Switch menu between HJY Software Application and Origin Pro button .

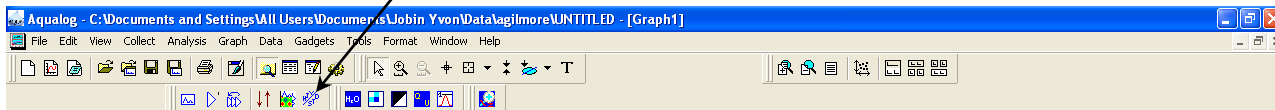

The menus at the top of the **Aqualog** window change.

- 2 Click the Switch menu between HJY Software Application and Origin Pro button  again to return to the original menu functions.

# Quinine Sulfate Units button

## Introduction

Used together with the Quinine Sulfate standard kit (calibrated for 5 nm bandpass) available from Starna, this function provides a standardized intensity for fluorescence measurements and EEMs.



**Note:** The Quinine Sulfate standard kit, RM QS-00, is available from Starna Cells, Inc., 5950 Traffic Way, Atascadero, CA 93422; phone: 800-228-4482; 805-466-8855; website is [www.starnacells.com](http://www.starnacells.com)

## Method

- 1 In the main toolbar, click the Quinine Sulfate Units button 

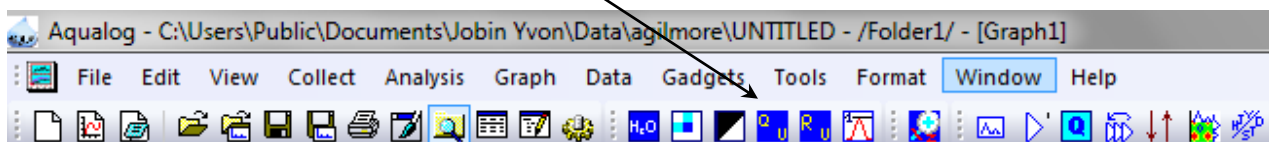

The **Experiment Setup** window appears:

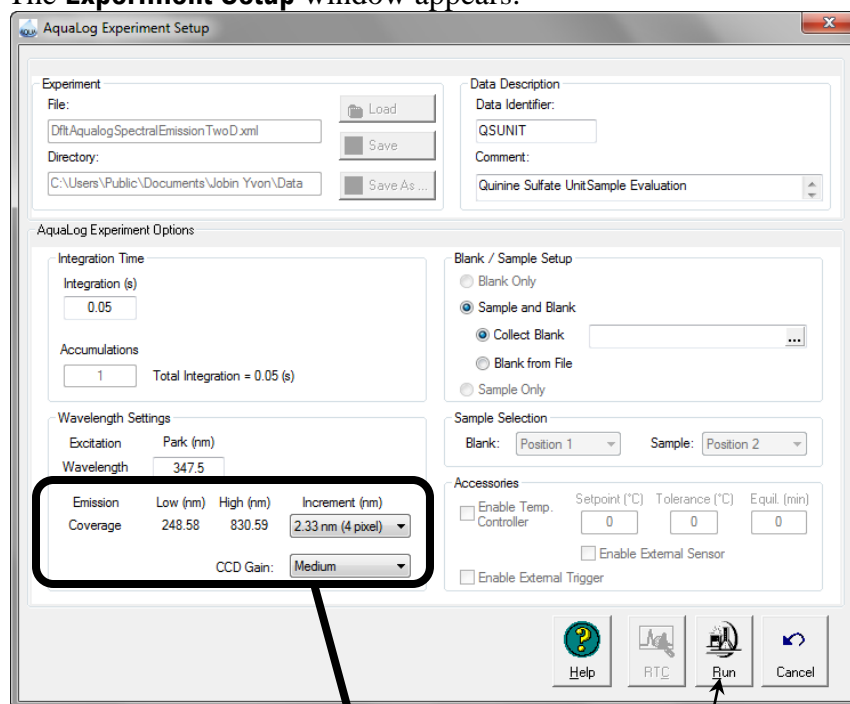

- 2 Adjust the Increment drop-down menu (i.e., pixel-binning) and CCD Gain drop-down menu as necessary.
- 3 Click the Run button.

The **Experiment Paused** window appears, prompting you to insert the blank.

4 In the sample compartment, insert the Quinine Sulfate blank from the Standard Kit.

5 Close the sample-compartment lid.

6 Click the OK button.



The **Experiment Status** window appears, and the scan starts.



The **Experiment Paused** window appears again, prompting you to insert the sample.

7 Remove the blank, and insert the sample.

8 Close the sample-compartment lid.

9 Click the OK button.



The scan completes, and the **Project Name** window appears.

10 Click the Cancel button.

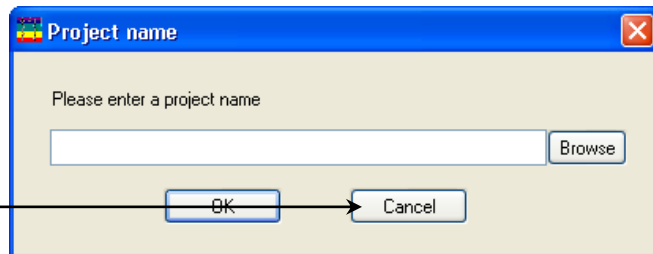

Tables appear:

	F1(Y)	G1(Y)	A(X)	B(Y)	C(Y)	D(Y)	E(Y)	F(Y)	G(Y)
Long Name	QSU Conditions		QSU	QS-Observed	QSU Calculated	Emission at 450 nm	QSU	EEM Integration Time	QSU Adjust
Units	Emission		Abs at 347.5 nm	Abs at 347.5 nm	Units	Counts (S1cR1c)	Normalization Factor		
Comments	Match for EEMs		Standard	Observed	Observed	Observed	Calculated	Enter in Row 1	
1	Integration Time, s	0.05	0.01384	0.01342	0.96978	3216.91737	3317.17234	1	66343.44683
2	Emission Increment, nm	2.34							
3	Gain Setting	Medium							

You can account for the different integration time than the EEM by changing the Integration Time from 1 to another value:

	F1(Y)	G1(Y)	A(X)	B(Y)	C(Y)	D(Y)	E(Y)	F(Y)	G(Y)
Long Name	QSU Conditions		QSU	QS-Observed	QSU Calculated	Emission at 450 nm	QSU	EEM Integration Time	QSU Adjust
Units	Emission		Abs at 347.5 nm	Abs at 347.5 nm	Units	Counts (S1cR1c)	Normalization Factor		
Comments	Match for EEMs		Standard	Observed	Observed	Observed	Calculated	Enter in Row 1	
1	Integration Time, s	0.05	0.01384	0.01342	0.96978	3216.91737	3317.17234	2	132686.89365
2	Emission Increment, nm	2.34							
3	Gain Setting	Medium							
4									

Note how the QSU Adjust value changes in response to a different Integration Time.

# Profile Tool button

## Introduction

This function provides a user-specified two-dimensional profile of an EEM.

## Method

- 1 With an EEM open, in the main toolbar, click the Profile Tool button .

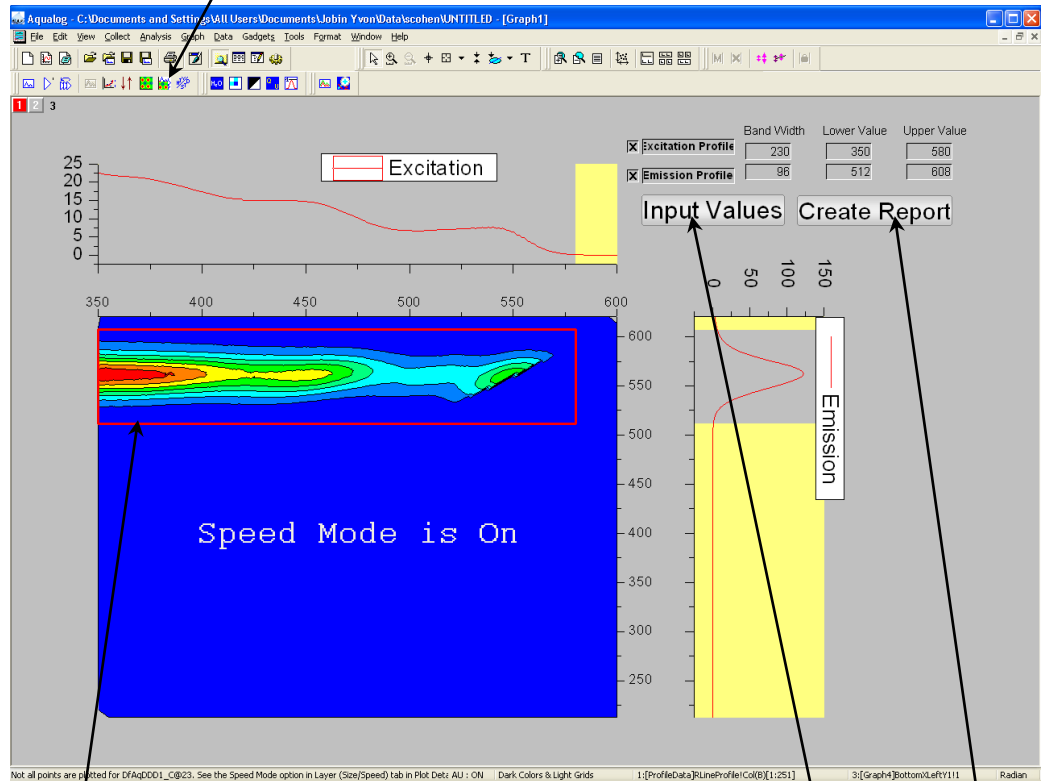

- 2 Move the boundaries of the red box to examine different cross-sections of the EEM, or click the Input Values button.
- 3 Use the Input Values window to enter manually the values of the cross-section.
- 4 Click the Create Report button.

A report appears:

Aqualog C:\Documents and Settings\All Users\Documents\Urbain Yvon\Data\cohen\UNTITLED - [Graph1]

File Edit View Collect Analysis Graph Data Gadgets Tools Format Window Help

Long Name	A(X1)	B(Y1)	C(X2)	D(Y2)	E(Y2)	F(Y2)
Units	EX nm			EM nm	Excitation	Emission
Comments		Excitation		Emission		
Lower		350		511.56		
Upper		580		607.58		
1	580	0.1762	511.609	0.91576		
2	579	0.18194	513.278	1.18949		
3	578	0.24318	514.947	1.53086		
4	577	0.26287	516.616	1.99046		
5	576	0.30688	518.286	2.5539		
6	575	0.38882	519.956	3.30413		
7	574	0.41193	521.627	4.27798		
8	573	0.50315	523.297	5.43276		
9	572	0.57431	524.968	6.94115		
10	571	0.69109	526.64	8.8151		
11	570	0.8536	528.311	10.93399		
12	569	0.89995	529.983	13.58768		
13	568	1.11408	531.656	16.80118		
14	567	1.18861	533.328	20.40799		
15	566	1.42819	535.001	24.79477		
16	565	1.74345	536.674	29.58993		
17	564	1.86049	538.348	34.97468		
18	563	2.18637	540.021	41.16781		
19	562	2.28844	541.695	47.78287		
20	561	2.67769	543.37	54.82249		
21	560	3.17779	545.044	62.46667		
22	559	3.26063	546.719	70.14551		
23	558	3.77922	548.394	77.84754		
24	557	3.8413	550.07	86.05435		
25	556	4.39229	551.746	93.4125		
26	555	4.94334	553.421	100.1911		
27	554	4.9264	555.098	107.10018		
28	553	5.47912	556.774	112.73682		
29	552	5.47455	558.451	117.66538		
30	551	5.96745	560.128	121.27901		
31	550	6.47487	561.805	122.51035		
32	549	6.41989	563.483	122.00666		
33	548	6.95973	565.161	120.30427		
34	547	6.73625	566.839	116.68226		
35	546	7.10917	568.517	111.54884		
36	545	7.45087	570.195	105.25211		
37	544	7.28223	571.874	97.15774		
38	543	7.57379	573.553	88.61037		
39	542	7.33964	575.233	79.33149		
40	541	7.58289	576.912	70.58333		
41	540	7.75218	578.592	62.28061		
42	539	7.50494	580.272	54.57731		
43	538	7.67838	581.952	47.39588		
44	537	7.38335	583.632	41.28637		

Processed Graph: IFE\_RM\_NRM / Processed Data: IFE\_RM\_NRM / Processed XYZ: IFE\_RM\_NRM / Processed Contour: IFE\_RM\_NRM / Profile /

AU : ON 25: [DfAgDD1]Profile1 Radian

# Rescale Y button

## Introduction

When a graph is open, this button rescales the y-axis on a graph to fit the data on-scale.

## Method

- 1 With a graph open, in the main toolbar, click the Rescale Y button .

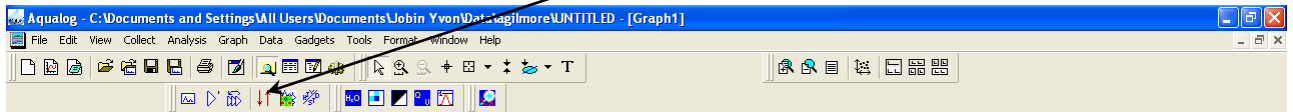

The graph gets rescaled.

# Automatic sample queueing

## Introduction

The Aqualog<sup>®</sup> software includes automatic sample and blank batch-processing (a “queue”) to assist with recording and analyzing your spectra, to perform up to 1000 automated sample measurements with complete acquisition, processing, and export of data files.



**Note:** Only experiments generated from the Sample Queue menu can be used in the Sample Queue operation. Conventional experiment files are not compatible.

## Method

- 1 In the Aqualog<sup>®</sup> software main window, click the Sample Queue button .

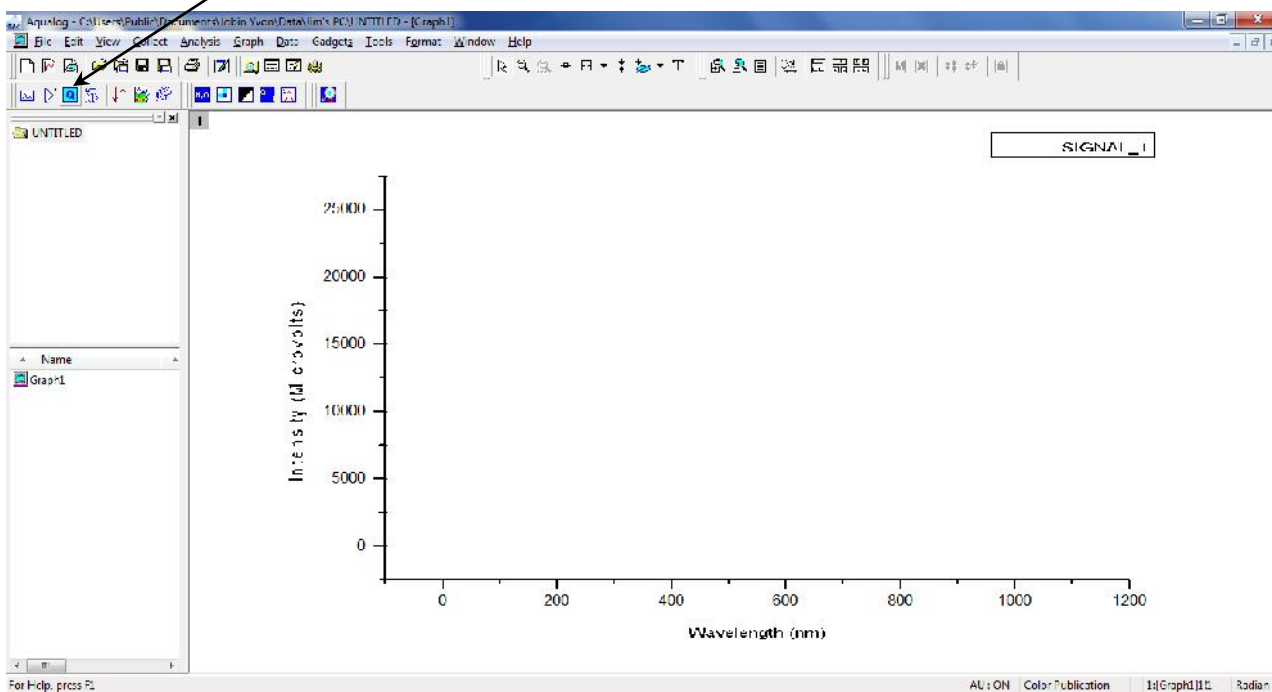

The **Sample Queue Setup** window appears:



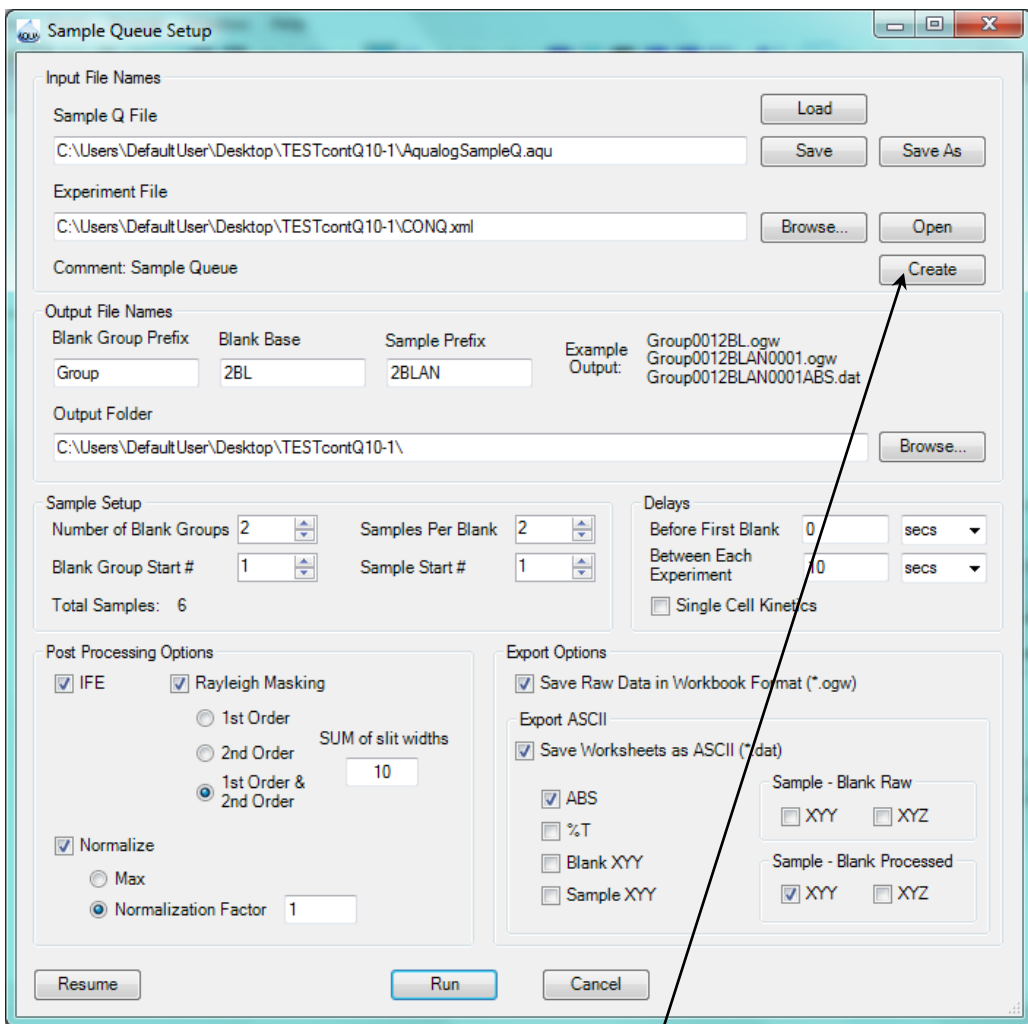

2 Click the Open button or the Create button.

The **Aqualog Experiment Setup** window appears:

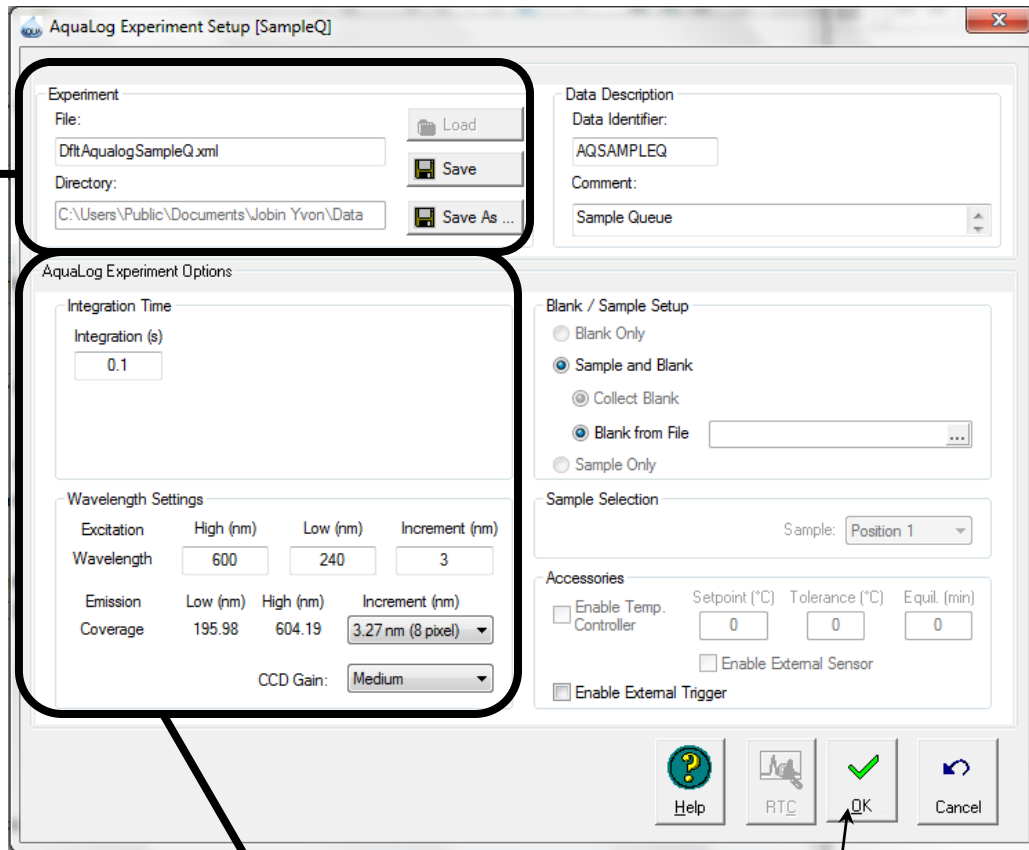

### 3 Set up the experiment file.

- a You can edit the default parameters for the experiment:
  - Integration Time
  - Wavelength settings
  - Enable External Trigger checkbox activated
- b Rename the file if you like.
- c Click the Save button.
- d Click the OK button.

The **Sample Queue Setup** window appears.

- e Set up the names for the output files in the Output File Names area. There is one workbook created for the sample, and one for the blank. The naming convention is based on three parts of the file name:

Blank Group Prefix	Blank Base	Sample Prefix	Example Output:
Group	Blank	Sample	Group001Blank.ogw Group001Sample0001.ogw Group001Sample0001ABS.dat

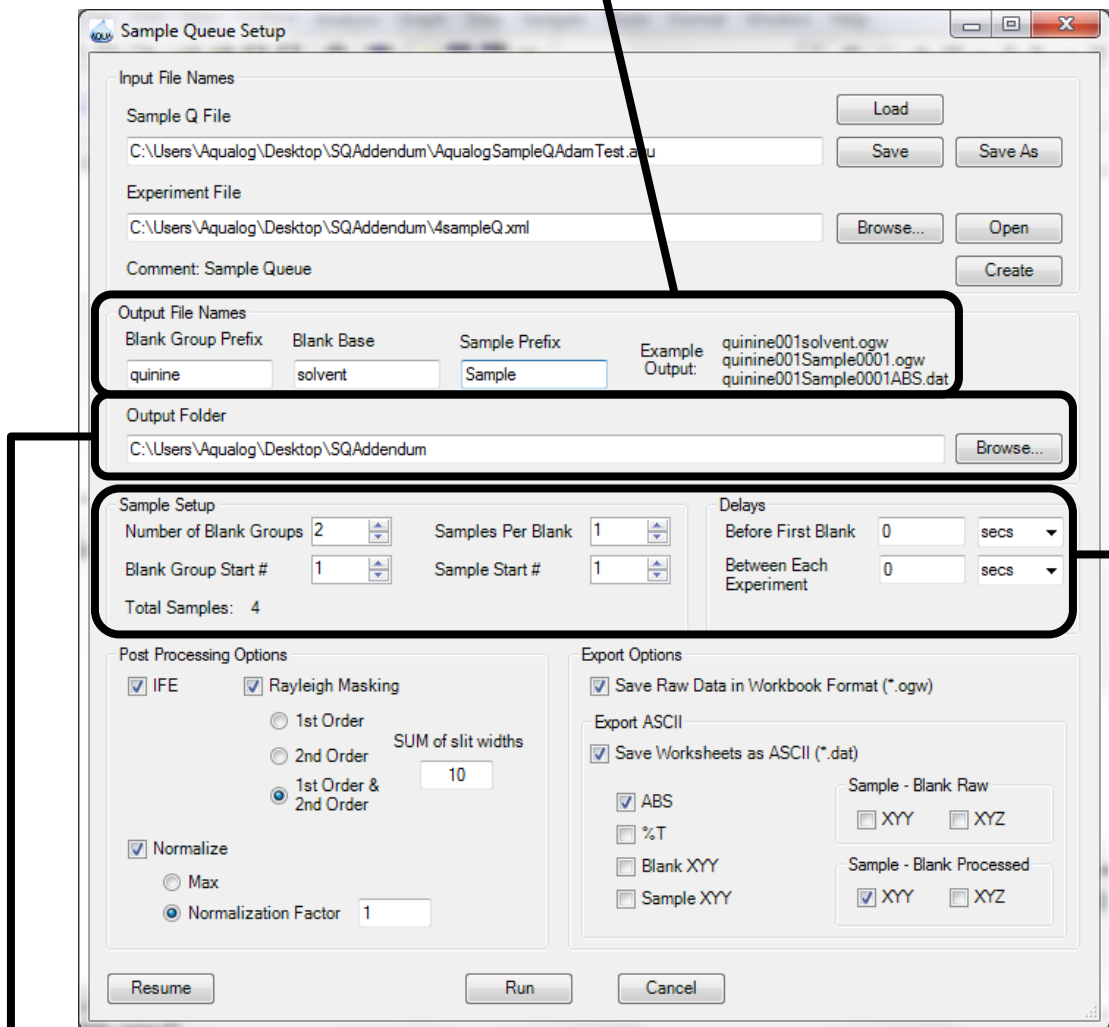

- f In the Output Folder area, set up the folder where the output data are saved. You may browse for the folder using the Browse... button, or create a new one. If you browse for the folder, the **Browse for Folder** window opens. Choose the desired folder and click the OK button.

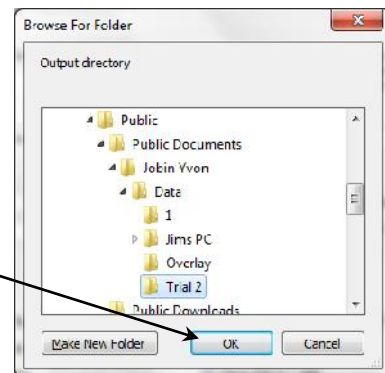

- g Set up the batch processing in the Sample Setup area. Number of Blank Groups is the number of samples associated with each particular blank. Blank Group Start # is the numeric portion of the blank's file name, xyz, which increments by 1 for the next blank.

**Sample Start #** is the numeric portion of the sample's file name, *xyz*, which increments by 1 for the next sample.

h

Do batch data-correction in the **Post Processing Options** area.

Those checkboxes activated in this area affect the **Sample – Blank Processed** checkbox in the **Export Options** area.

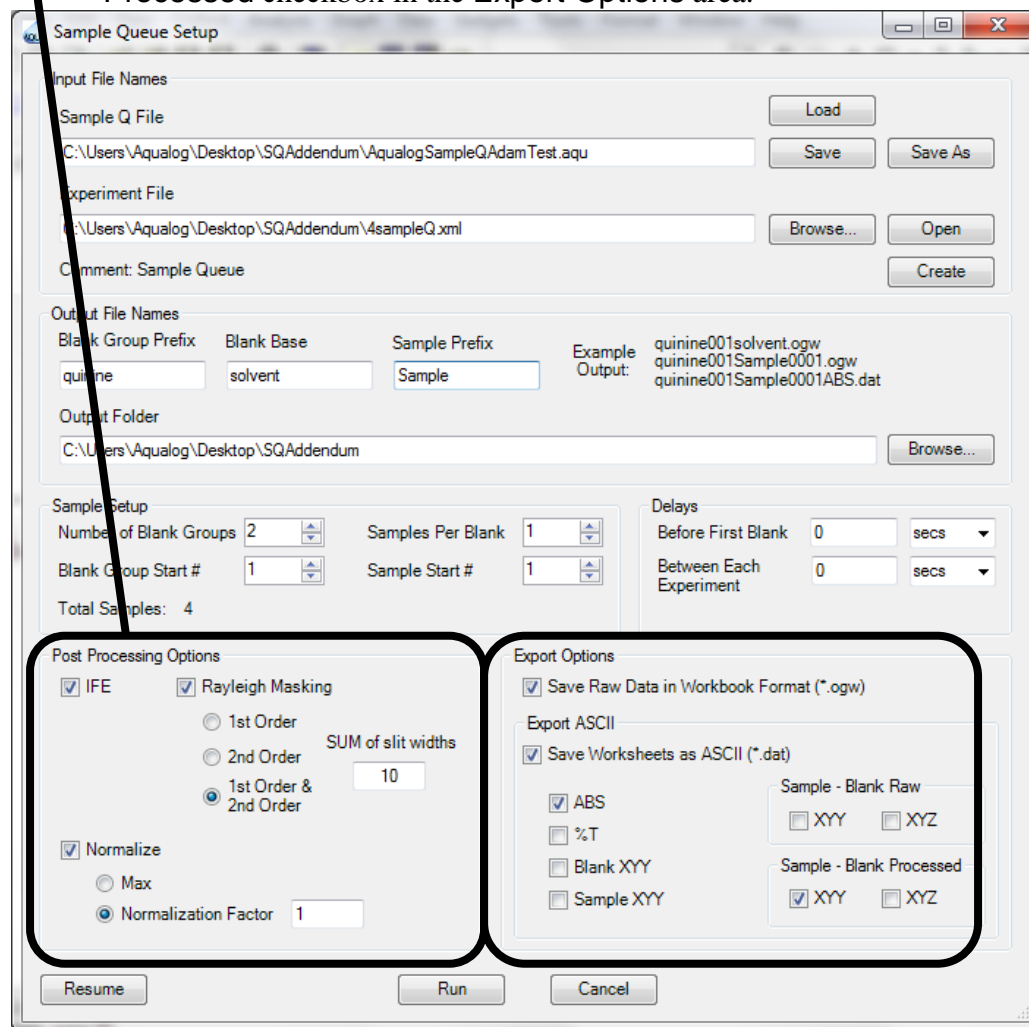

i

Choose the batch export options in the **Export Options** area.

If you choose the `.ogw` workbook format for your data, this uses large amounts (megabytes) of storage space. ASCII format uses only kilobytes of storage.

Most users are interested primarily in the **Sample – Blank Processed** results and absorbance (`*.ABS`) data files.

An example of a fully-completed **Sample Queue Setup** window is shown below:

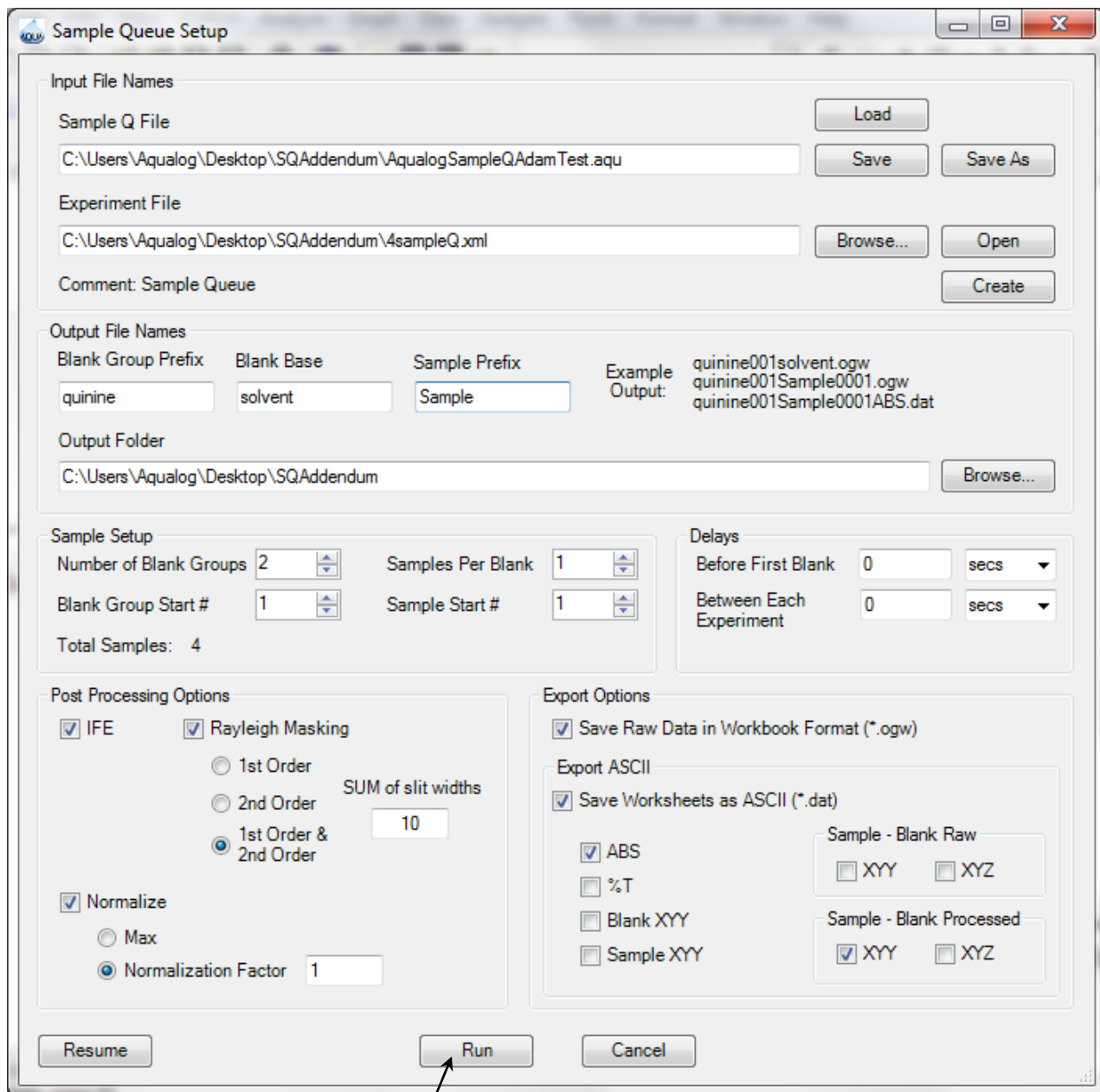

4 Click the Run button to start the queue.

Depending on your instrument configuration, an **Insert Sample** window or **Please Change Samples** window like this may appear:

- a Insert the blank into the sample compartment, and click the OK button or the Continue button.

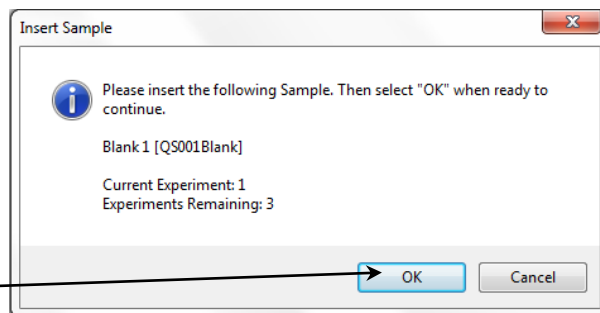

Example of a set-up with samples to be changed manually

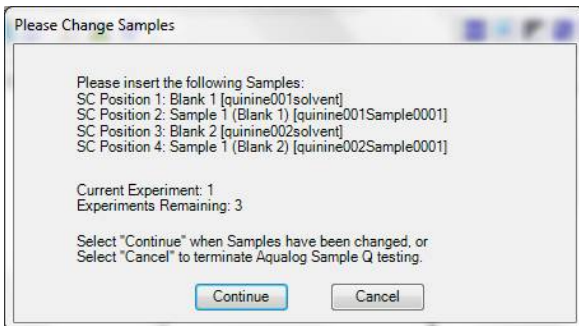

Example of a set-up with an automatic sample-changer

As data are collected, a status update appears in one area of the Aqualog<sup>®</sup> software window:

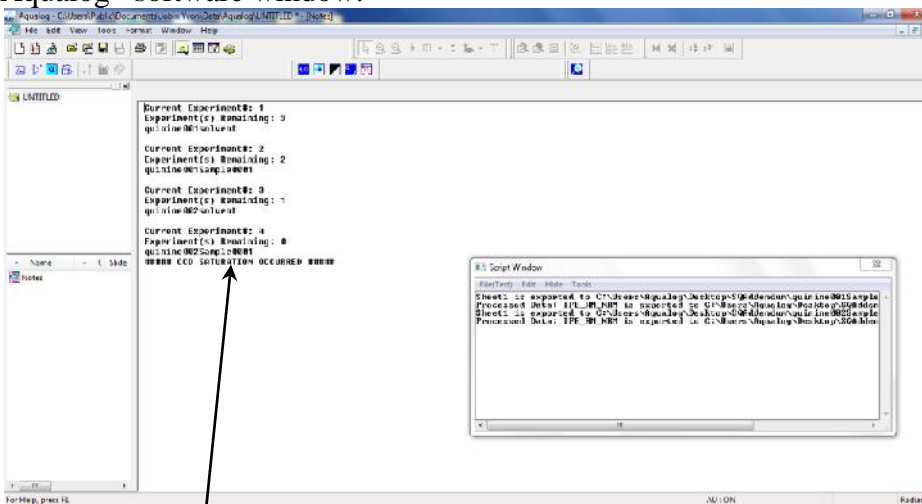

Notice the warning listed in the status that the CCD signal for this experiment became saturated.

The **Intermediate Display** appears:

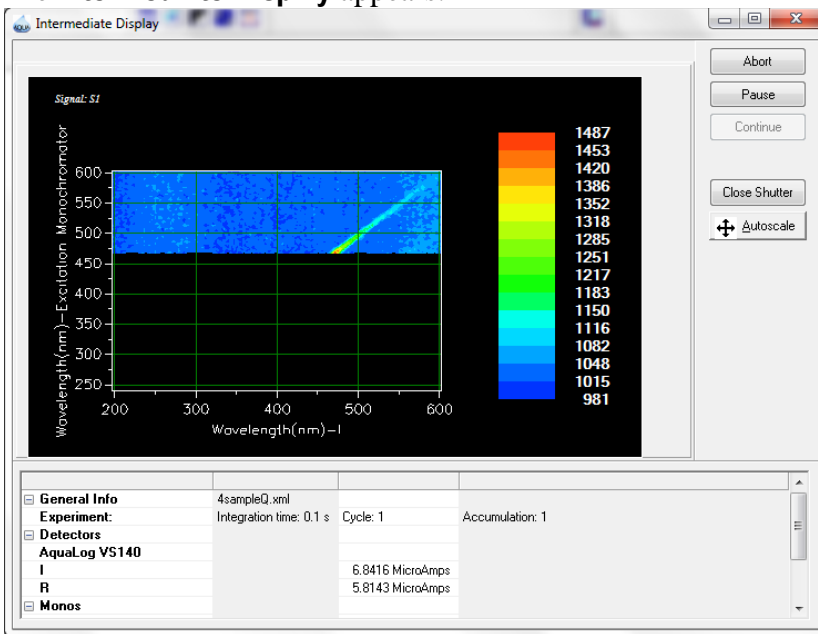

- b Continue to insert blanks and samples as prompted, if necessary. When the scans are done, the data are saved in files according to the set-up. The **Aqualog Sample Q** window appears.
- c Click the OK button to continue.

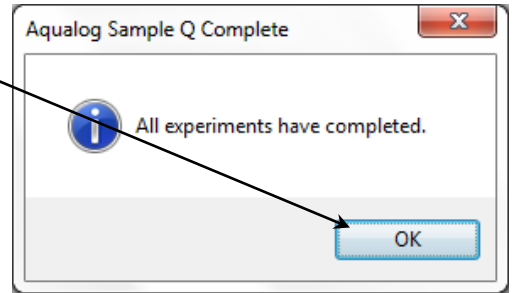

## 5 Open the log file if desired:

- a In the toolbar, choose File. A drop-down menu appears.
- b Choose Open....

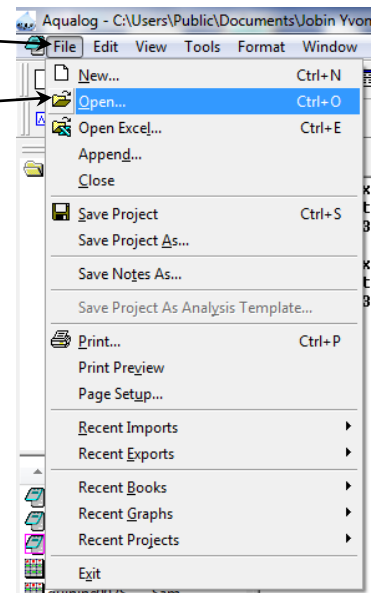

The **Open** window appears:

- c In the Files of type drop-down menu, choose Notes (\*.txt).
- d Highlight the desired log file to open.
- e Click the Open button.

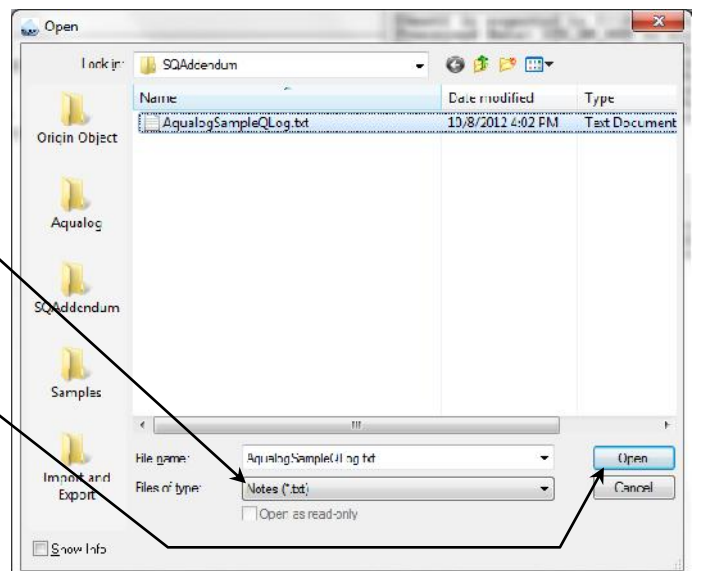

The log file appears:

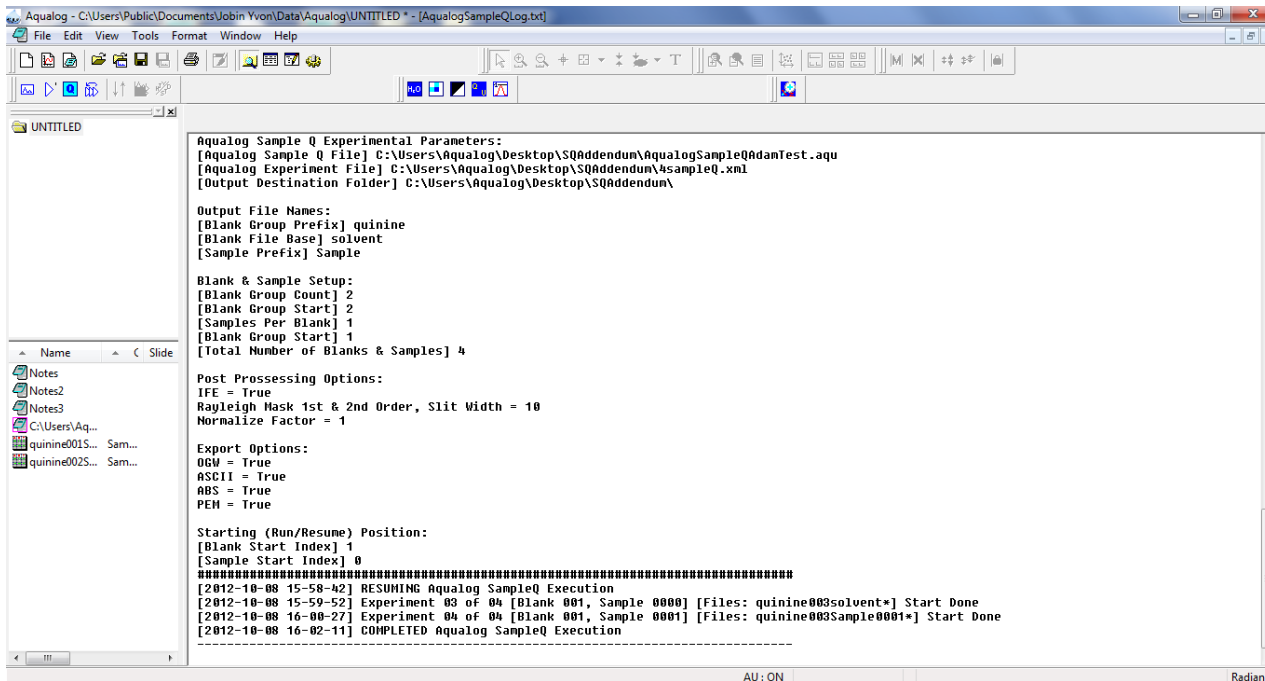

## 6 Open and view the data.

You can open the data or project in the same way as typical Origin<sup>®</sup> projects. There are various types of scans you may have chosen to store:

Type of scan	Three-letter code in file name	File type
Raw data in workbook	--	W
Absorbance	ABS	t
% Transmittance	PCT	t
Blank EEM	BEM	t
Sample EEM	SEM	t
Sample – Blank EEM XYZ	SYM	t
Sample – Blank EEM XYZ	SCM	t
Processed Sample – Blank EEM Water-fall*	PEM	t
Processed Sample – Blank EEM Con-tour*	CEM	t

\*These scans have been processed and are ready for multivariate analysis.

Under File, choose Open..., then choose one or more files to open, and click the Open button. (Be sure to choose the correct file-type.)

The data appear in the main window:

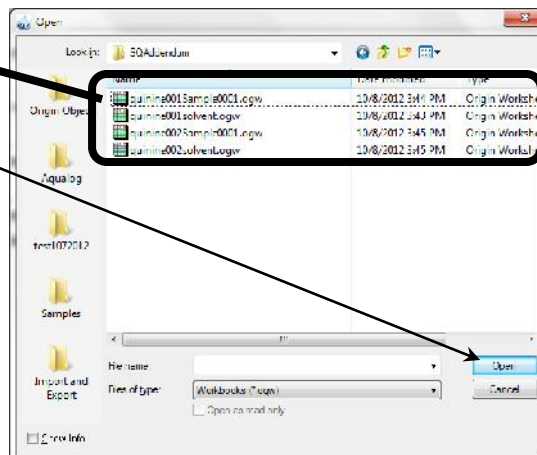



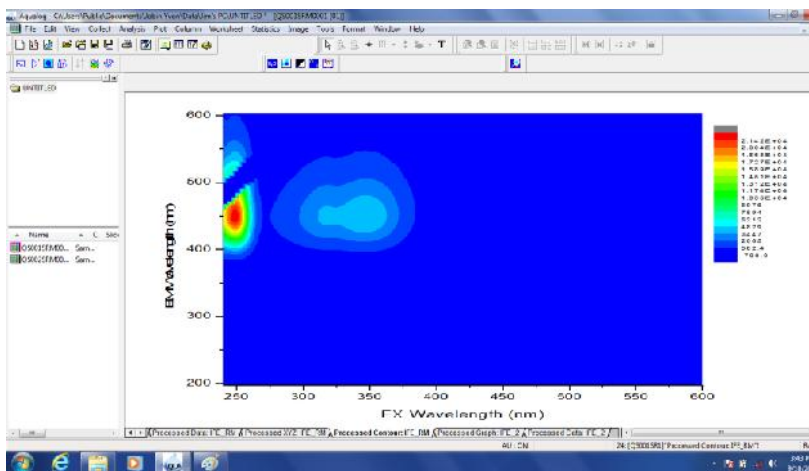

7 To optionally simulate 3D data, click the Solo+MIA icon on the desktop.



**Note:** The Solo+MIA optional function is used for multivariate analysis of the EEMs and absorbance spectral data.

### If the batch experiment was interrupted

Suppose there is a problem with the experiment: You choose to abort it halfway through, or perhaps there is a power interruption. The Sample Q software keeps track of where the batch experiment has been, so that you can recover without restarting the entire series of scans. Below is a log file showing that only two scans were run out of four:

The screenshot shows the Aqualog software interface. The main window displays a log file with the following text:

```

Current Experiment#: 1
Experiment(s) Remaining: 1
quinine001Sample

Current Experiment#: 2
Experiment(s) Remaining: 2
quinine002Sample0001
    
```

The 'Script: Window' is open, showing the following text:

```

Sheet1 is exported to C:\Users\Aqualog\Desktop\SQdndundun\quinine001Sample
Processed Data: IFE_RM_NRM is exported to C:\Users\Aqualog\Desktop\SQdndundun
Sheet1 is exported to C:\Users\Aqualog\Desktop\SQdndundun\quinine002Sample
Processed Data: IFE_RM_NRM is exported to C:\Users\Aqualog\Desktop\SQdndundun
Sheet1 is exported to C:\Users\Aqualog\Desktop\SQdndundun\quinine002Sample
Processed Data: IFE_RM_NRM is exported to C:\Users\Aqualog\Desktop\SQdndundun
    
```

- 1 Open the Sample Q file corresponding to the aborted experiment.

The Aqualog® software assumes that all conditions were saved before the experiment started.

- 2 Click the Resume button.

The **Aqualog Sample Q Resume** window appears, displaying the software's guess as to where the experiment ought to continue.

- 3 Correct, as needed, any parameters, then click the Resume button.

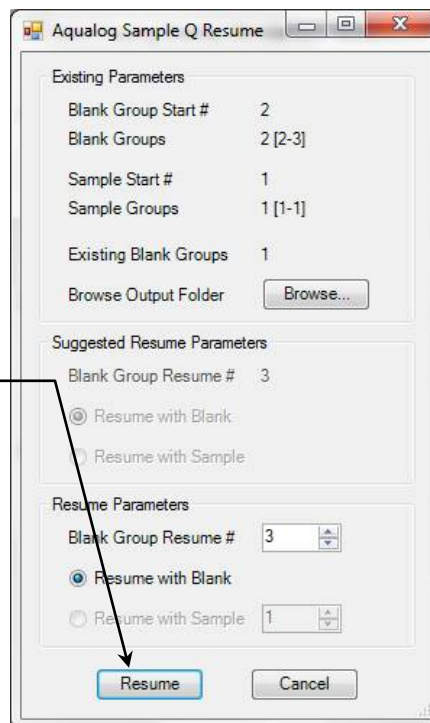

- 4 The software may prompt you to change the sample:

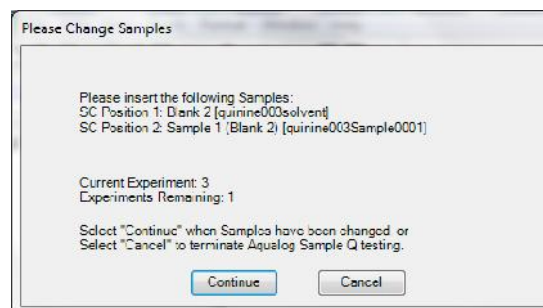

**Note:** Pay attention to the sample positions in the sample compartment before resuming an interrupted experiment.

At the end of the restarted experiment, the **Aqualog Sample Q Complete** window appears as usual:

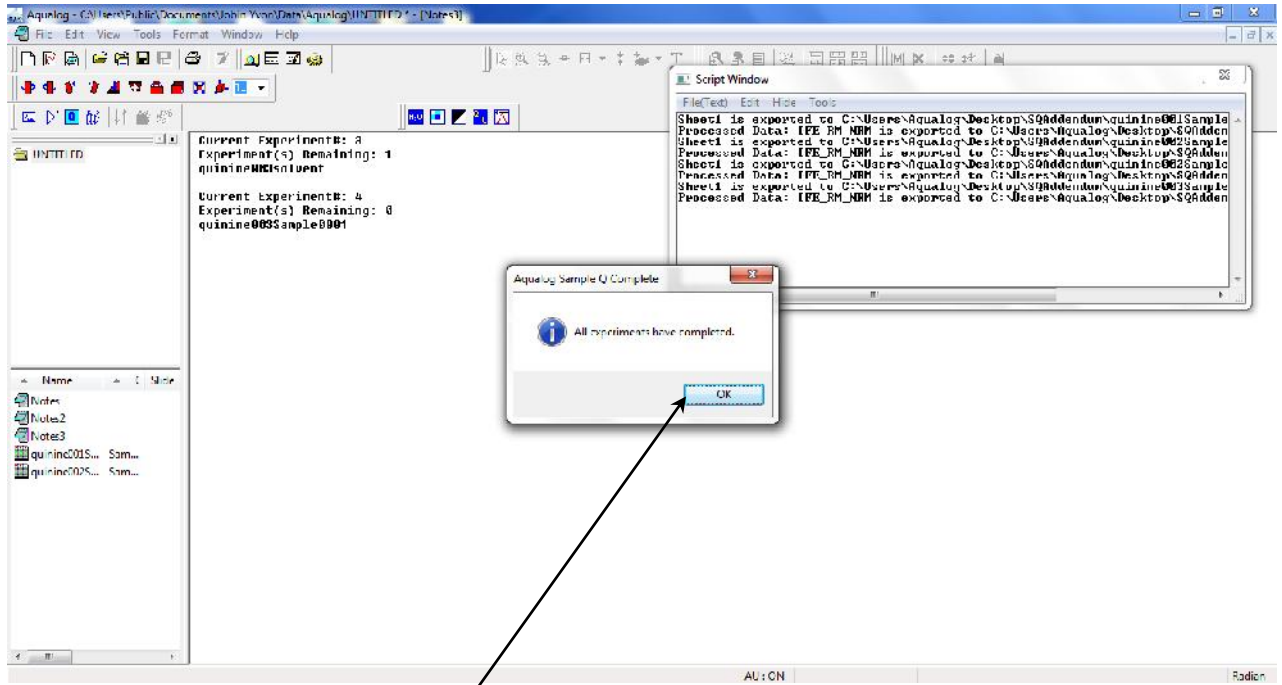

5 Click the OK button to continue.

6 Open the log file to show the interruption as recorded:

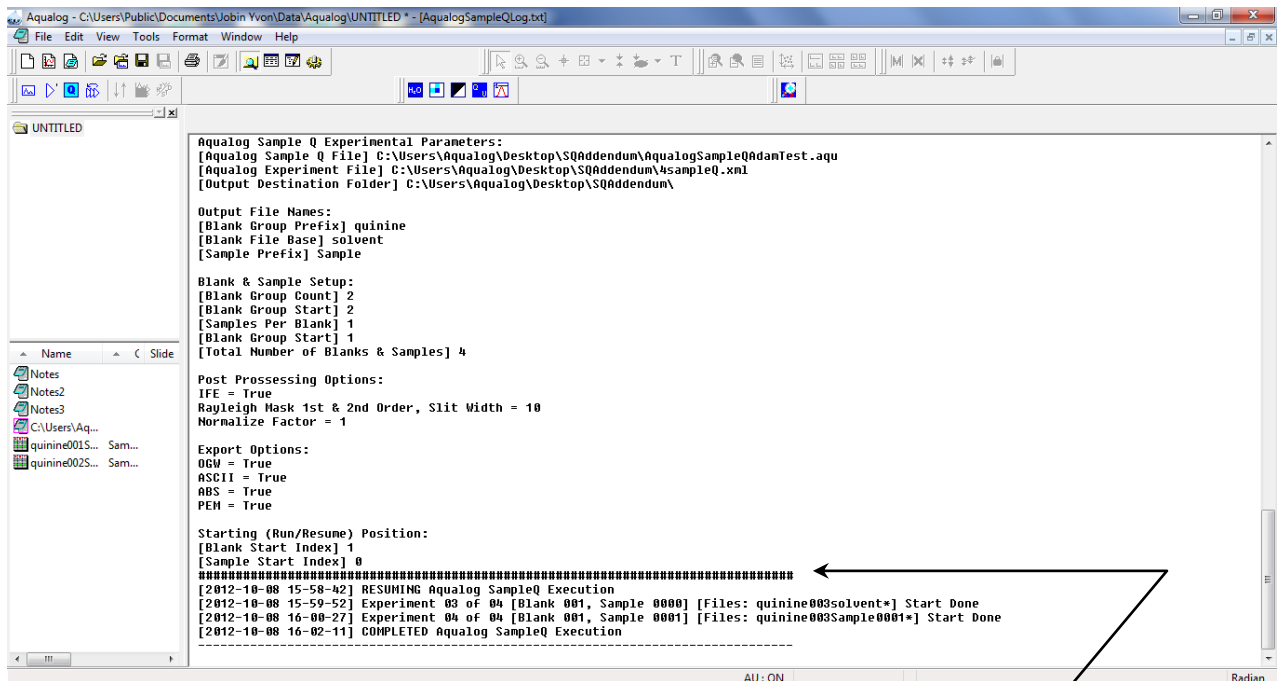

f Scroll to the bottom to see the interruption as recorded.

## Single-cell kinetics function

- 1 After clicking on the Sample Queue button  and opening the **Sample Queue Setup** window, activate the Single Cell Kinetics checkbox:

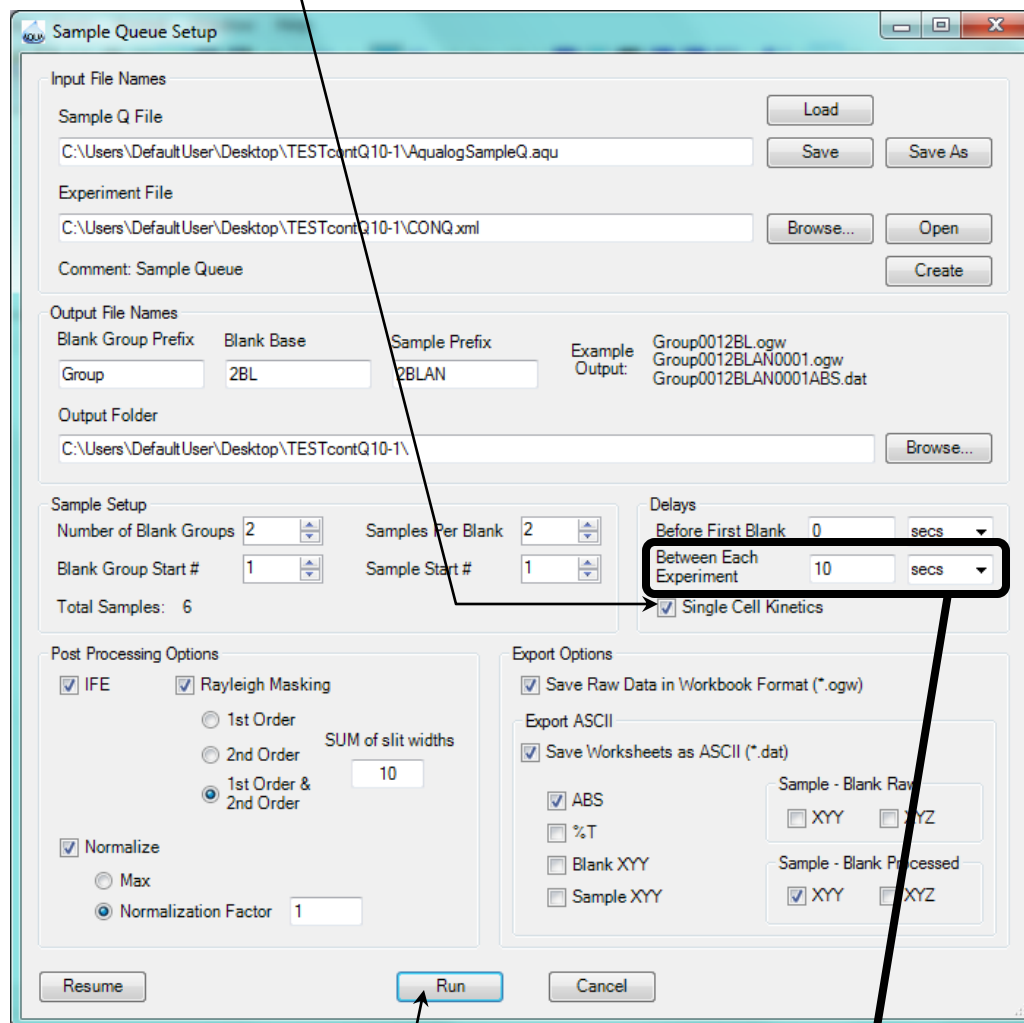

- 2 Choose the desired delay between each experiment by filling in the Between Each Experiment field in the Delays area.
- 3 Click the Run button when all parameters are set.

The **Output Parameters Validation** window appears and asks you if you want to overwrite the Output Files:



**Note:** You will only see this message if files have been recorded, so carefully consider whether to overwrite or alter the Queue file name settings.

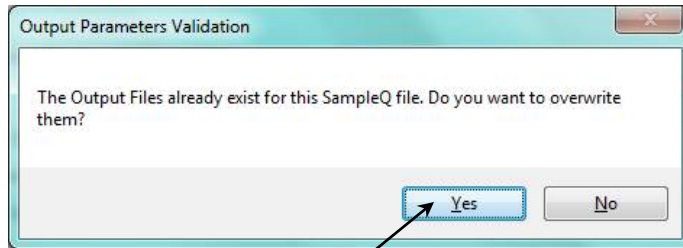

4 Click the Yes button.

The **Please Change Samples** window prompts you to change the sample in the sample compartment:

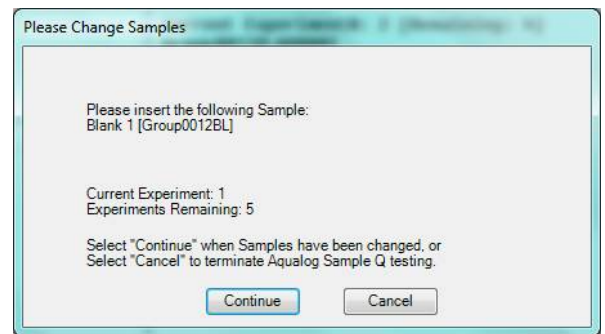

5 Place the blank into the sample compartment, close the lid, and click the Continue button.

The scan starts and the **Intermediate Display** appears, with the spectral data appearing in real time:

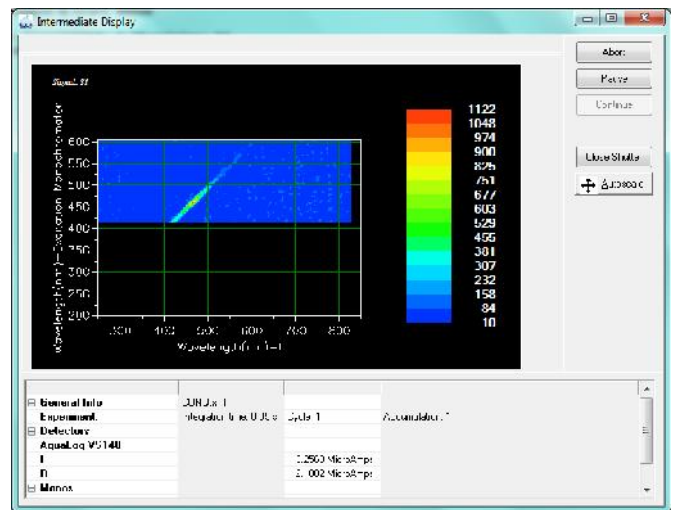

When the blank scan is finished, the **Please Change Samples** window reappears, prompting you to insert the sample:

6 Remove the blank from the sample com-

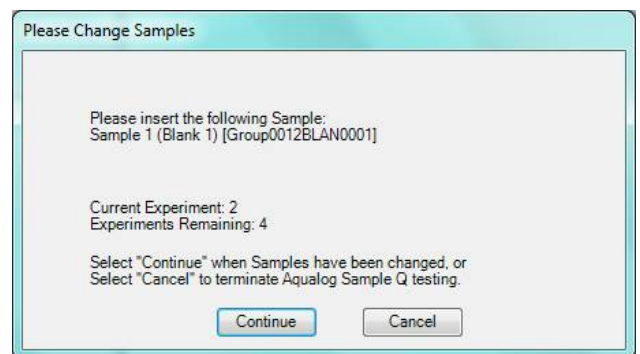

partment, place the sample in the sample compartment, close the lid, and click the Continue button.

The scan starts and the **Intermediate Display** appears, with the spectral data appearing in real time:

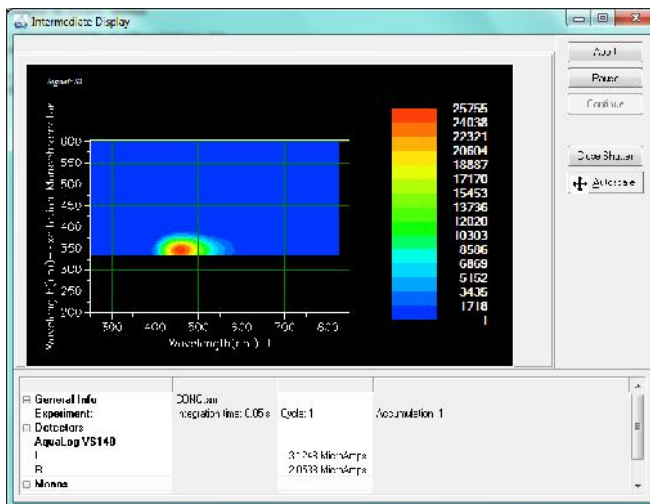

When the sample scan is complete, the **Waiting for Experiment Delay** window appears, showing the Delay Remaining until the next scan starts.

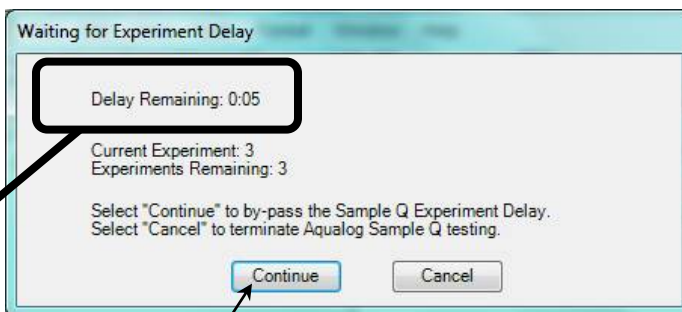

7 If you want to start the scan before the delay ends, click the Continue button. If you want to follow the programmed delay, let the clock run automatically.

The next scan starts automatically, and the **Intermediate Display** appears.

The programmed cycle continues till the scans and delays are finished.

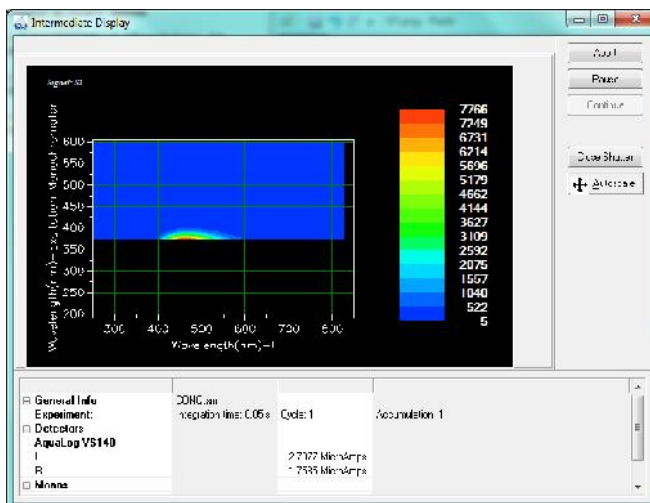



# Raman Scattering Area Unit button

The Raman Scattering Area Unit button is an alternate method to the Quinine Sulfate button for normalizing EEM data, as well as providing a check of throughput and calibration.

- 1 Click the Raman Scattering Area Unit button .

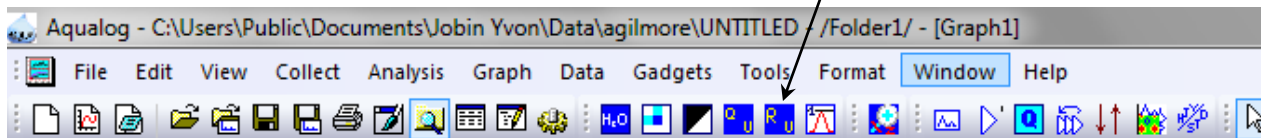

The **Aqualog Experiment Setup** window appears:

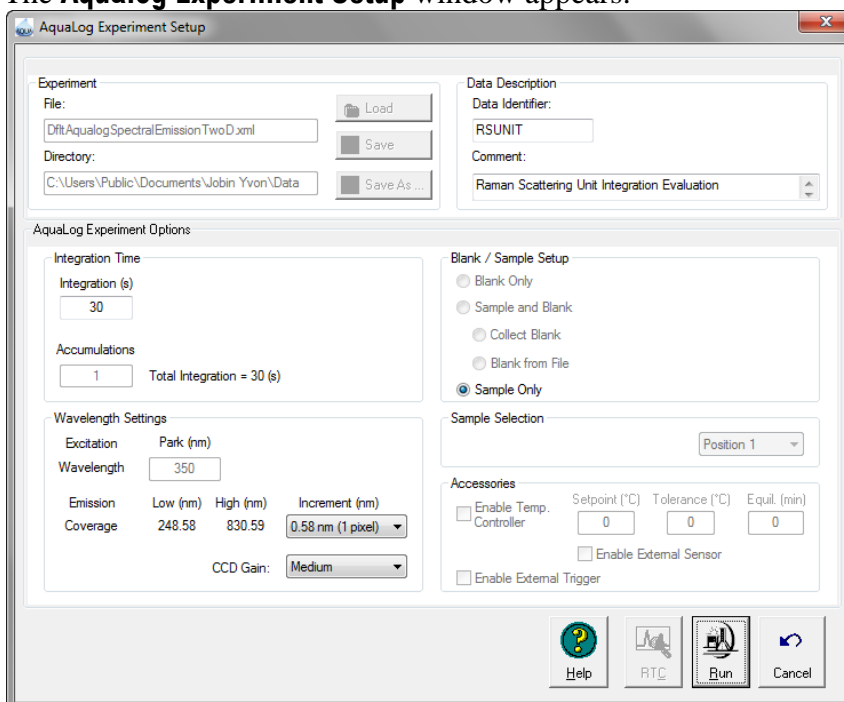

- 2 Adjust the Increment (i.e., the binning of the pixels) drop-down menu and CCD Gain drop-down menu as necessary:

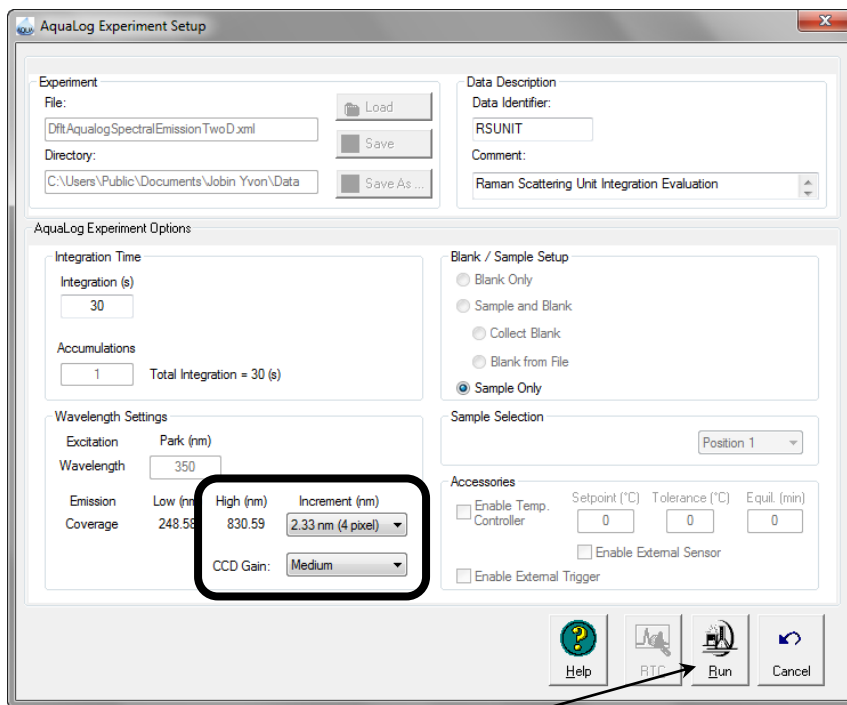

3 Click the Run button.

The **Experiment Status** window appears as the data are collected.

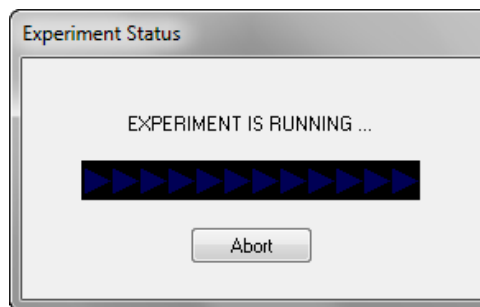

The **Project name** window appears.

4 Enter a name or click the Cancel button.

A series of graphs and tables appear. A pertinent graph is the water-Raman peak:

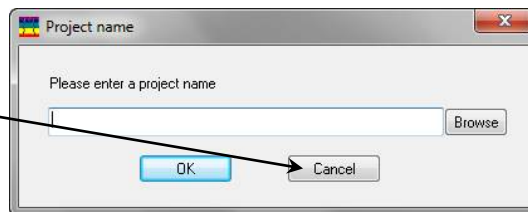



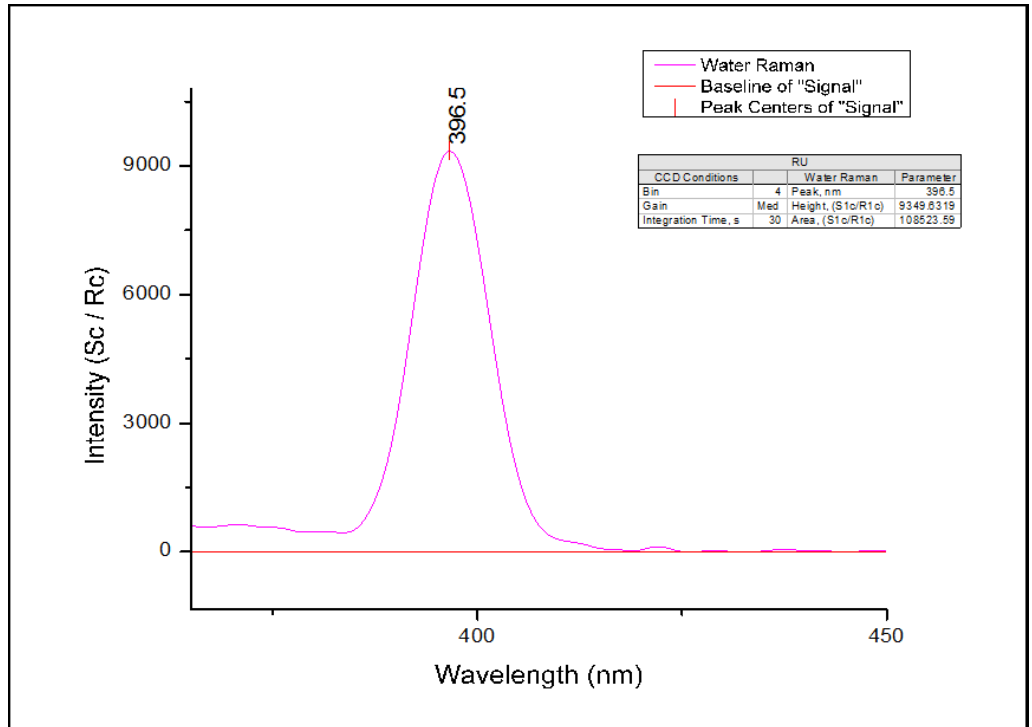

5 Also, view the RSU-Adjust tab:

	A(X)			D(Y)
Long Name	Water Raman Parameter	Water		RSU Adjust
Units				
Comments				
1	Integration Time, s	30	1	--
2	Area	108523.59381		3617.45313
3	Intensity	9349.63191		311.6544
4		--		
5		--		
6	Bin	4		
7	Gain	Med		

6 You can enter a new Integration Time in column C, based upon the integration time used in your EEM:

	A(X)	B(Y)	C(Y)	D(Y)
Long Name	Water Raman Parameter	Water Raman Value	Integration Time	RSU Adjust
Units				
Comments				
1	Integration Time, s	30	2	--
2	Area	108523.59381		7234.90625
3	Intensity	9349.63191		623.30879
4		--		
5		--		
6	Bin	4		
7	Gain	Med		

Note how the RSU Adjust values change when the Integration Time was changed from 1 to 2.



# 6: Various Experiment Types

## Introduction

This chapter explains how to run the most common types of experiments, using the Aqualog<sup>®</sup> instrument and software:

- Absorbance spectra
- Two-dimensional emission spectra
- Three-dimensional emission spectra (EEM)
- Kinetics spectra
- Single-point spectra

The chapter also explains what to do when you are examining an unknown sample.

# Absorbance spectra

- 1 If you have an automatic sample-changer, place the blank and sample in the sample-changer. If you have a single-position sample-holder, place the blank in the sample compartment.
- 2 Close the cover of the sample compartment.
- 3 In the main window, click the Experiment Menu button .

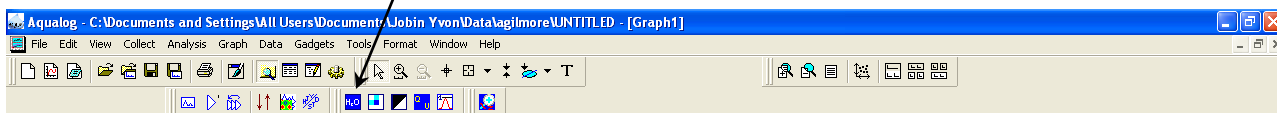

The **Aqualog Main Experiment Menu** opens.

- 4 Click the Spectra button.

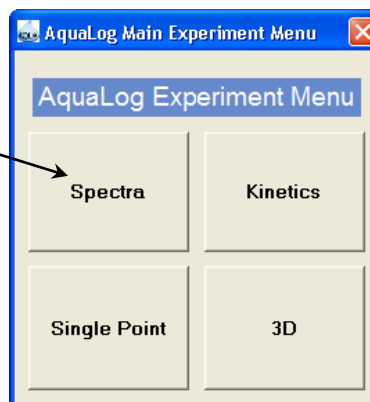

The **Aqualog Experiment Type** window opens.

- 5 Click Absorbance, then click the Next >> button.

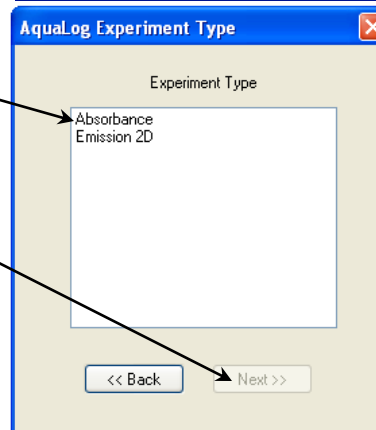

The **Aqualog Experiment Setup** window appears:

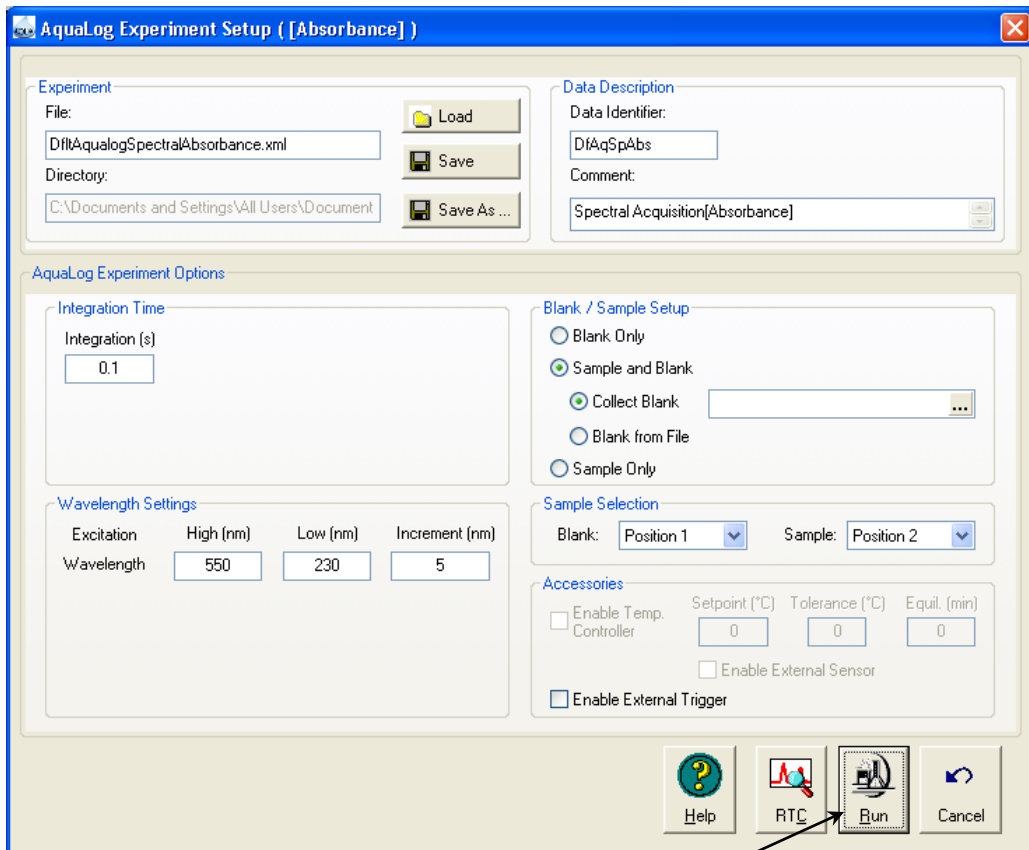

6 Set the experimental parameters.

7 Click the Run button .

If you have no automatic sample-changer, a prompt to insert the blank appears.

8 Insert the blank and close the cover of the sample compartment.

9 Click the OK button.



The **Intermediate Display** appears and the scan starts:

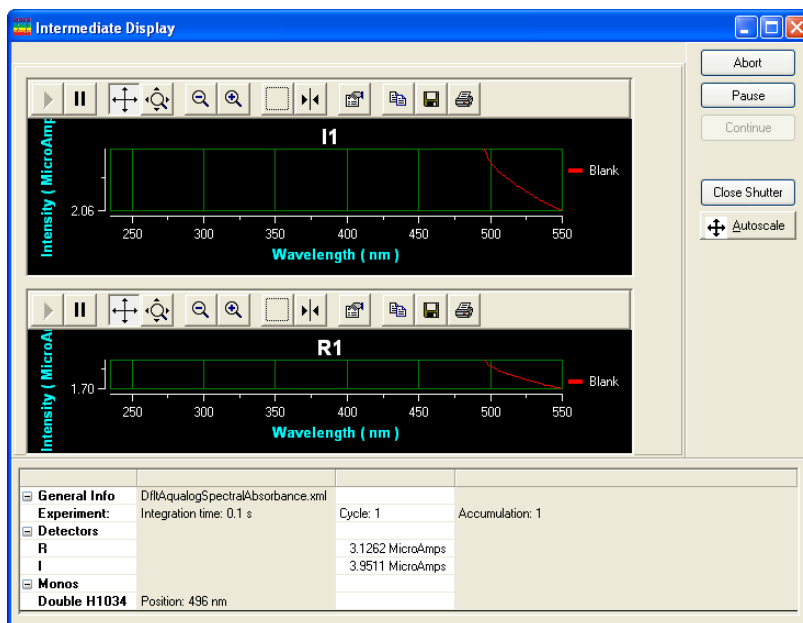

If you have no automatic sample changer, a prompt to insert the sample appears.

10 Insert the sample and close the cover of the sample compartment.

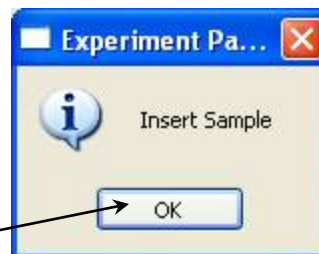

11 Click the OK button.

The **Intermediate Display** re-appears and the scan continues.

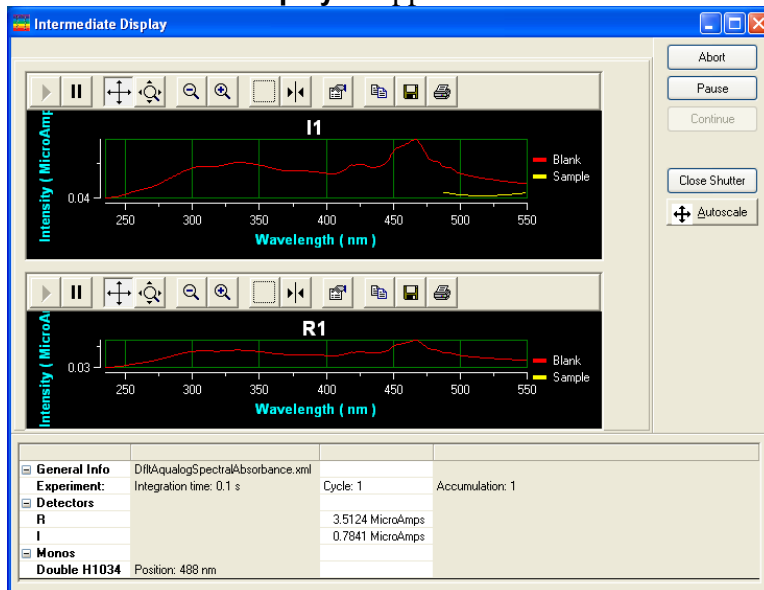

When the scan is complete, the **Project name** window appears.

12 Enter a name for the project and click the OK

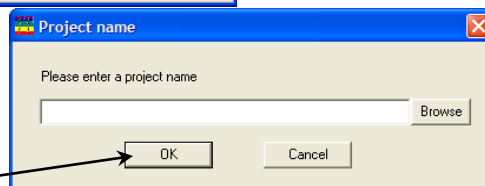

button, or, if you enter no name, click the Cancel button.

The absorption and transmission spectra appear:

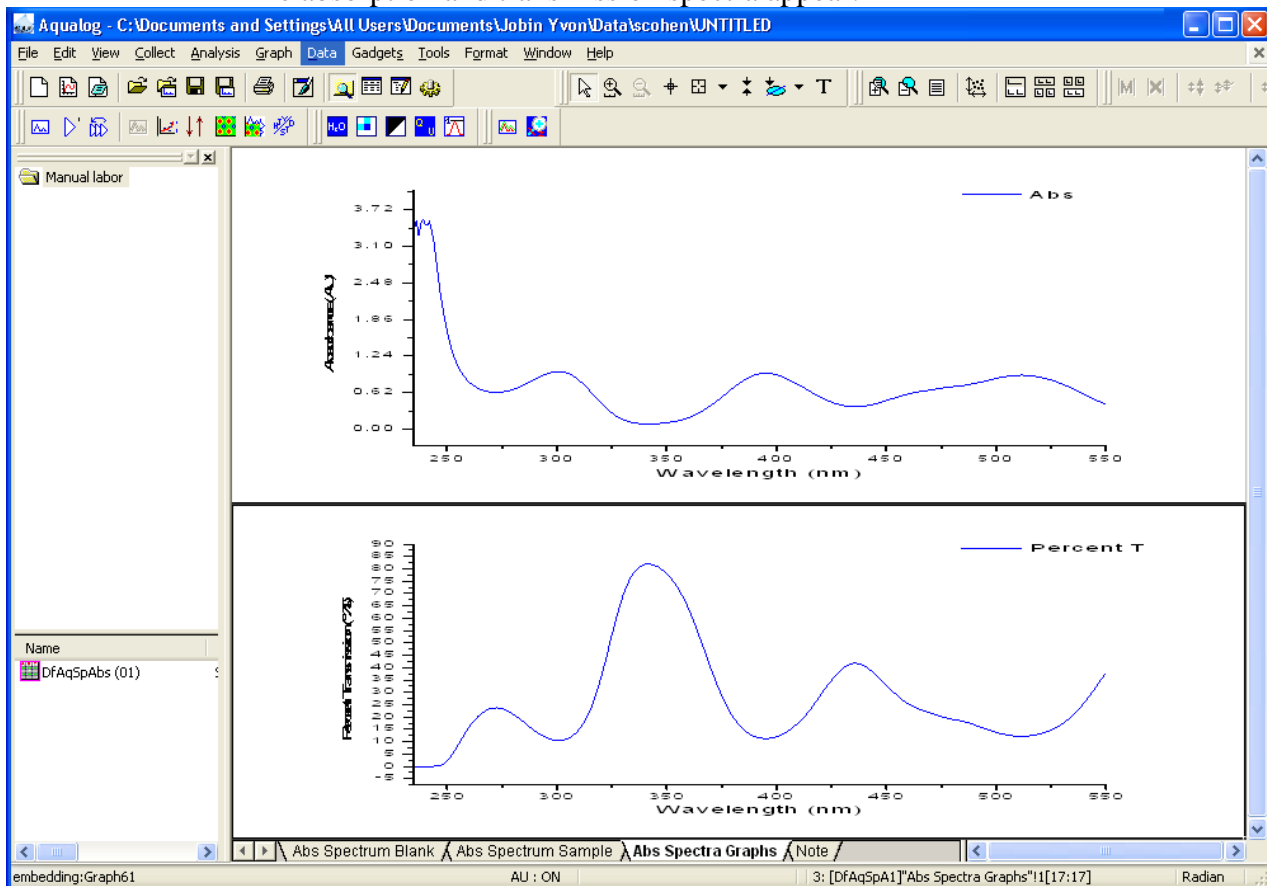

**13** Double-click on the spectrum to see it better in a separate window for editing.

# Two-dimensional emission spectra

- 1 If you have an automatic sample-changer, place the blank and sample in the sample-changer. If you have a single-position sample-holder, place the blank in the sample compartment.
- 2 Close the cover of the sample compartment.
- 3 In the main window, click the Experiment Menu button .

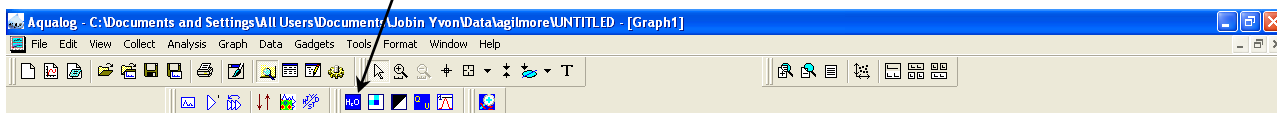

The **Aqualog Main Experiment Menu** opens.

- 4 Click the Spectra button.

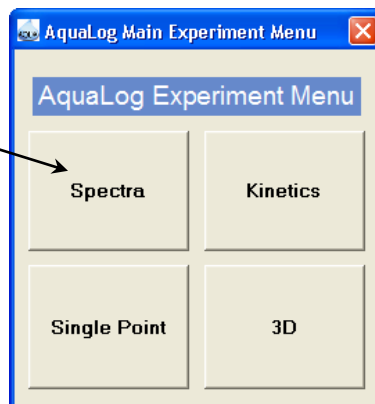

The **Aqualog Experiment Type** window opens.

- 5 Click Emission 2D, then click the Next >> button.

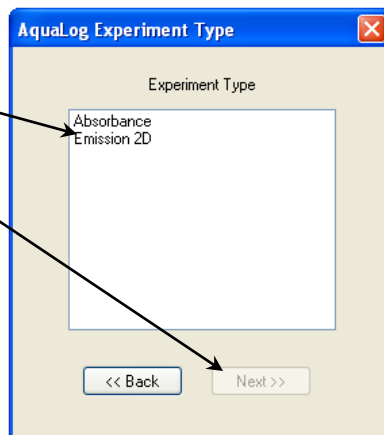

The **Aqualog Experiment Setup** window appears:



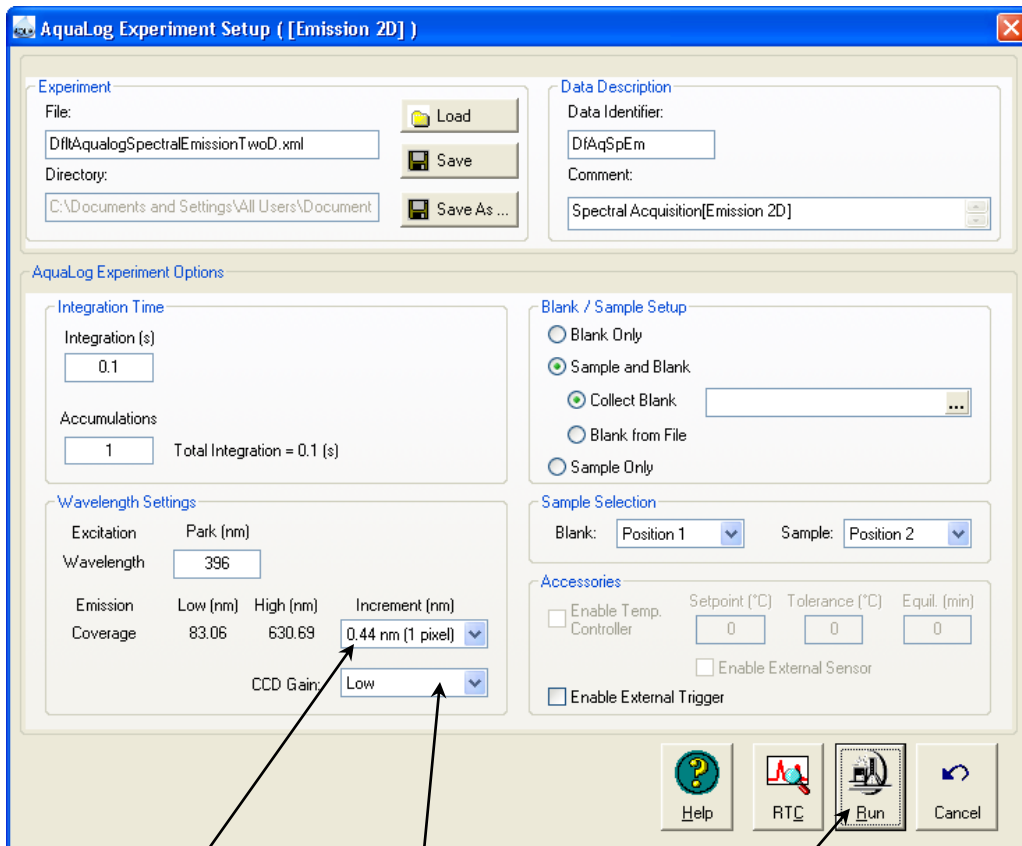

6 Set the experimental parameters.

- a To change the gain, in the CCD Gain drop-down menu, and choose the desired gain.
- b To change the pixel-binning, click the Increment drop-down menu and choose the amount of binning.

7 Click the Run button  when all parameters are set.

The **Experiment Status** window appears.

If you have no automatic sample-changer, a prompt to insert the blank appears.

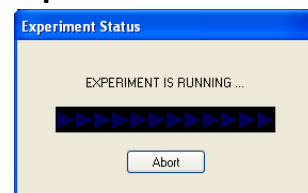

8 Insert the blank, close the sample-compartment cover, and click the OK button.

The scan continues. If you have no automatic sample-changer, a prompt to insert the sample appears.

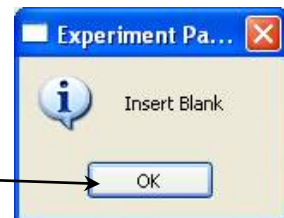

# 9 Insert the sample close the sample-compartment cover, and click the OK button.

The **Intermediate Display** appears:

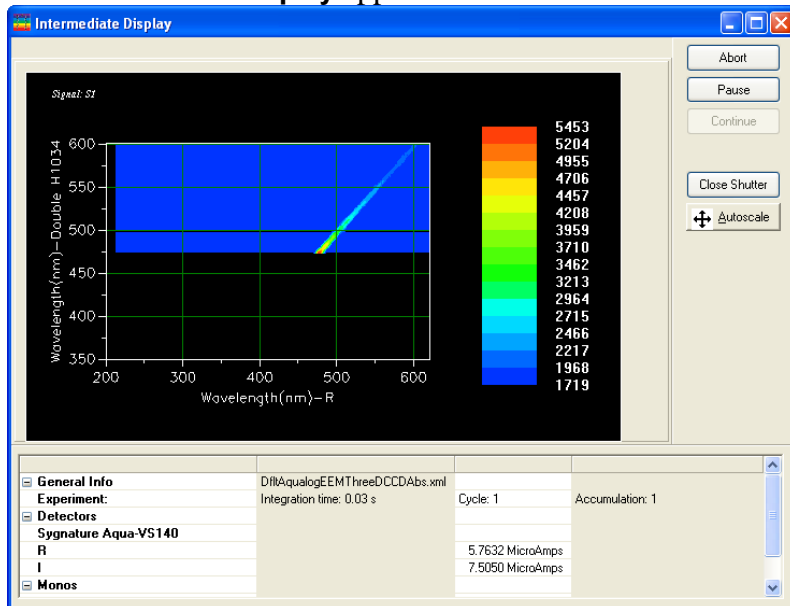

When the scan is complete, the emission spectrum appears. The dip on the spectrum is the Rayleigh-band absorbance. In the legend, you can see the excitation wavelength, absorbance, and transmission provided:

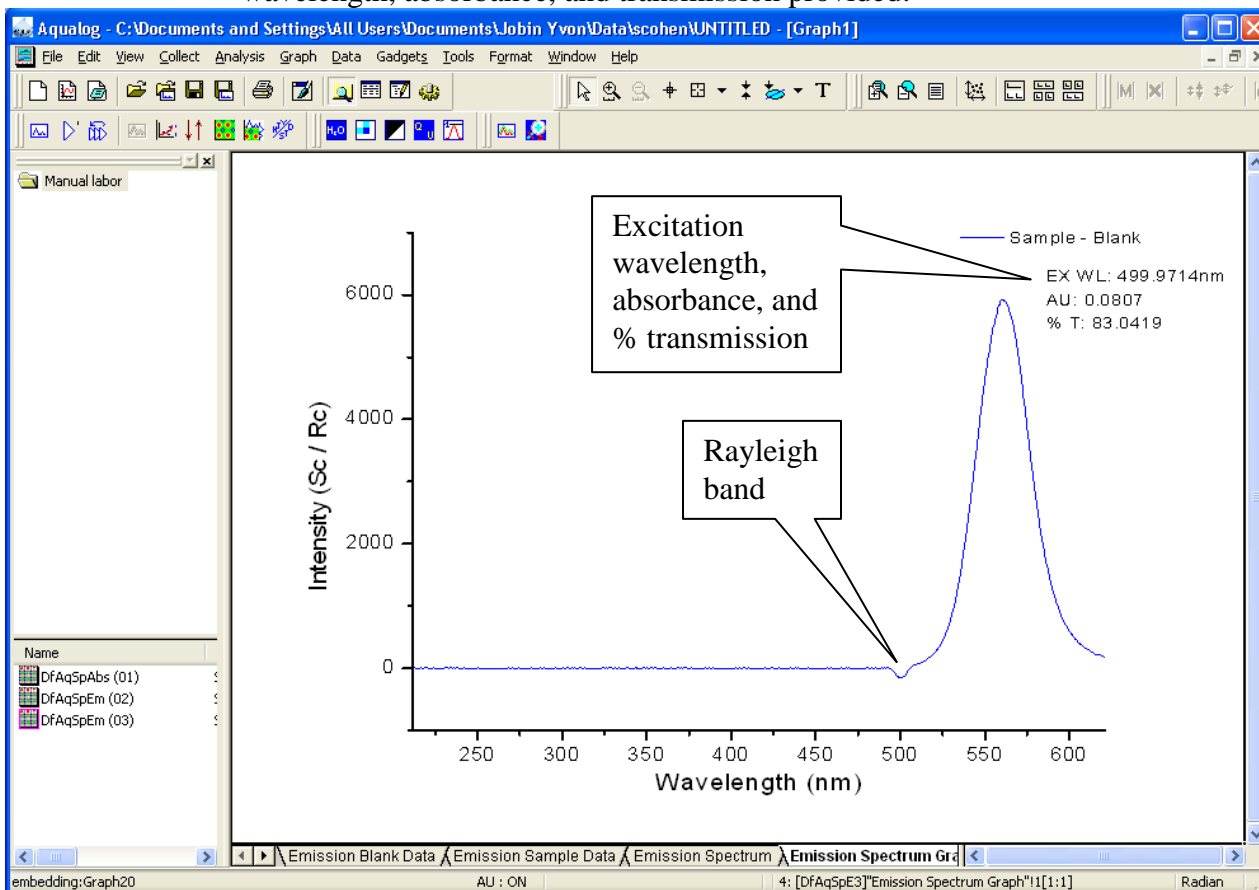

# Three-dimensional emission spectra

- 1 If you have an automatic sample-changer, place the blank and sample in the sample-changer. If you have a single-position sample-holder, place the blank in the sample compartment.
- 2 Close the cover of the sample compartment.
- 3 In the main window, click the Experiment Menu button .

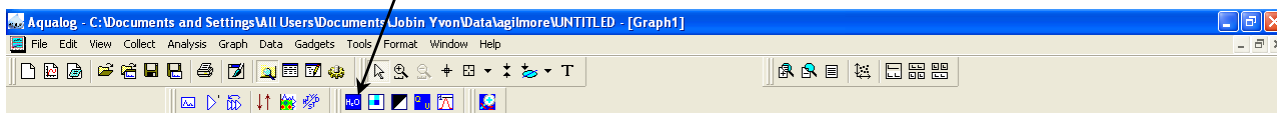

- 4 The **Aqualog Main Experiment Menu** opens.  
Click the 3D button.

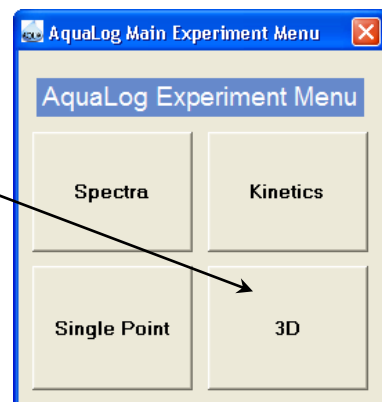

- 5 The **Aqualog Experiment Type** window opens.  
Click EEM 3D + Absorbance, then click the Next >> button.

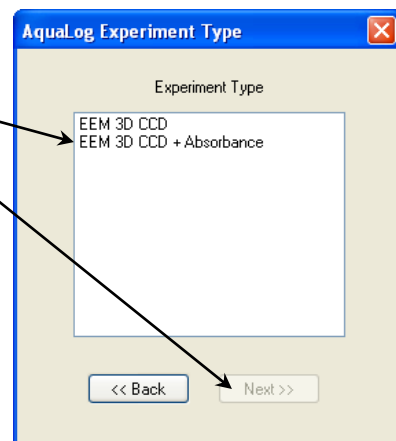

The **Aqualog Experiment Setup** window appears:

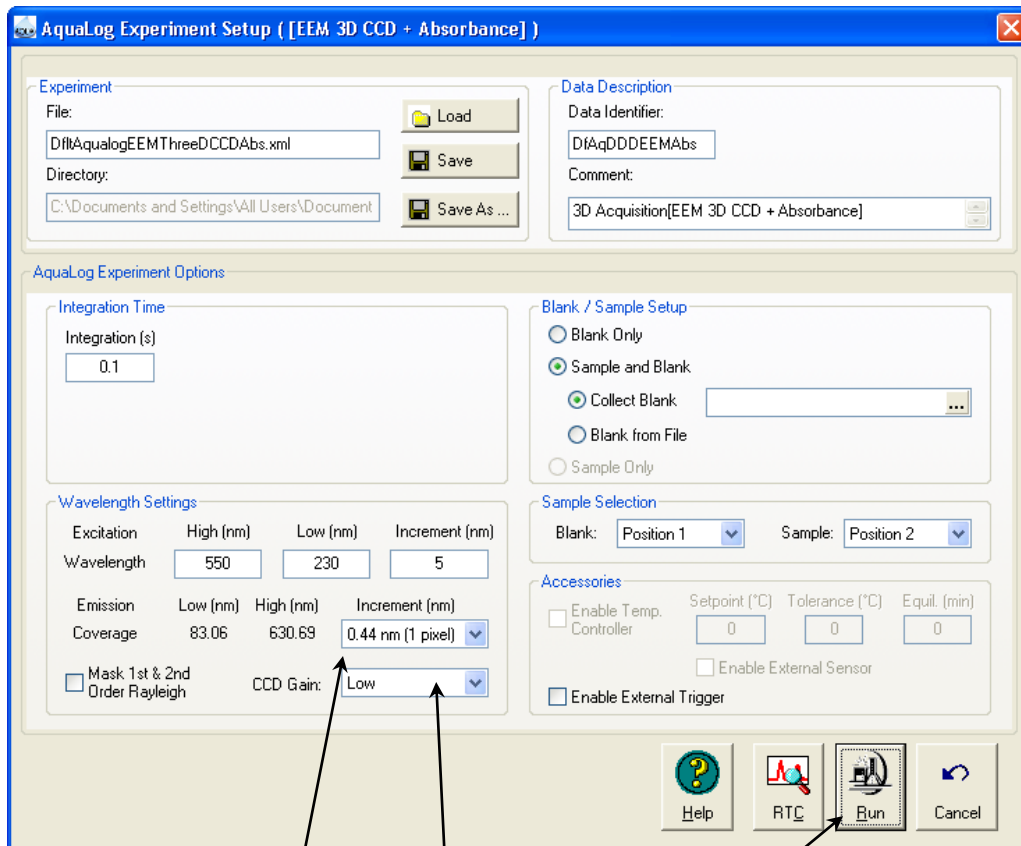

6 Set the experimental parameters.

- a To change the gain, in the CCD Gain drop-down menu, and choose the desired gain.
- b To change the pixel-binning, click the Increment drop-down menu.

7 Click the Run button  when all parameters are set.

The **Experiment Status** window appears. If you have no automatic sample-changer, a prompt to insert the blank appears.



8 Insert the blank, close the sample-compartment cover, and click the OK button.

The scan continues. If you have no automatic sample-changer, a prompt to insert the sample appears.



# 9 Insert the sample, close the sample-compartment cover, and click the OK button.

The **Intermediate Display** appears.

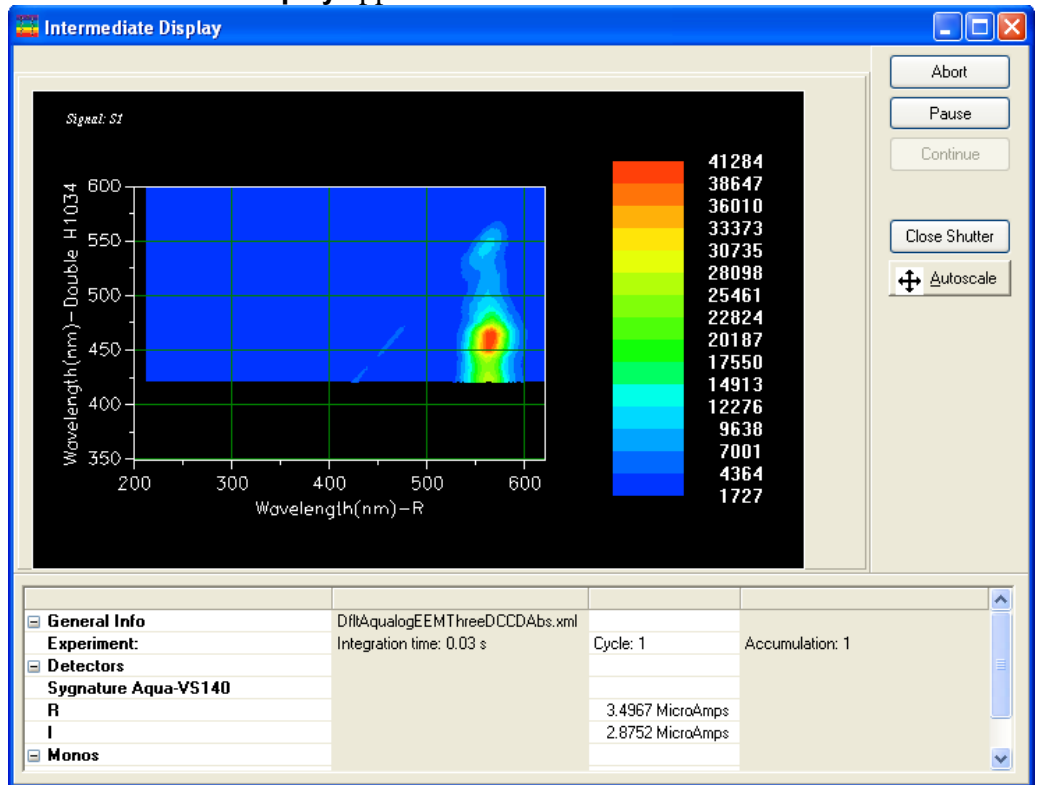

When the scan is complete, the emission spectrum appears. The dip in the spectra is the Rayleigh-band absorbance.

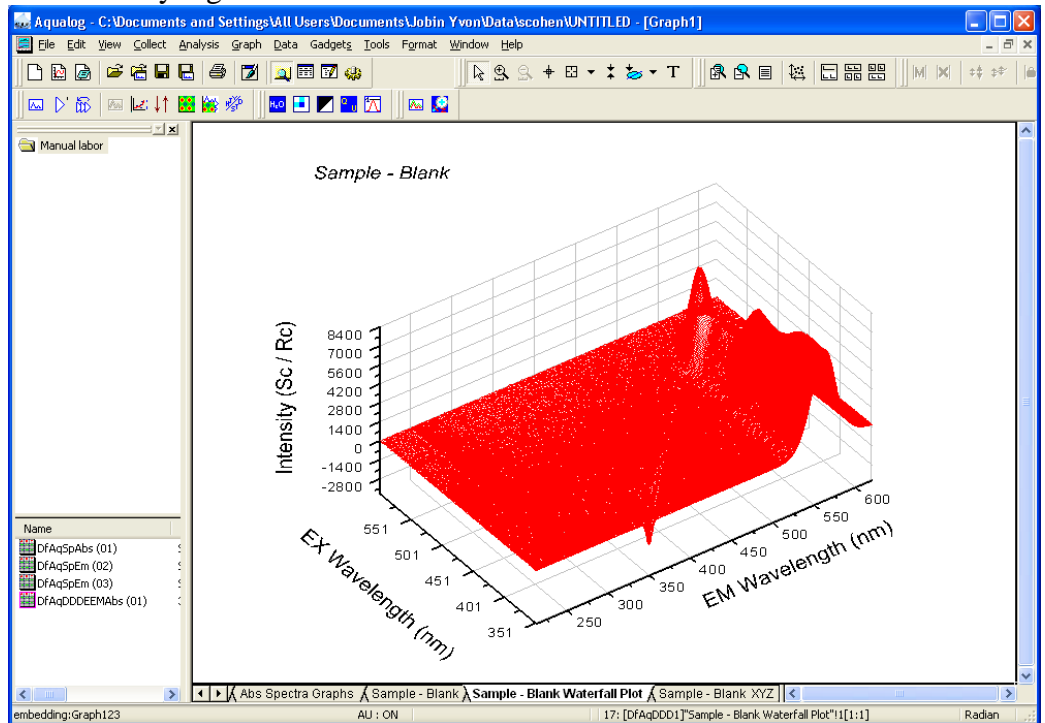

# 10 Click the Abs Spectra Graphs tab to see the absorption spectrum:

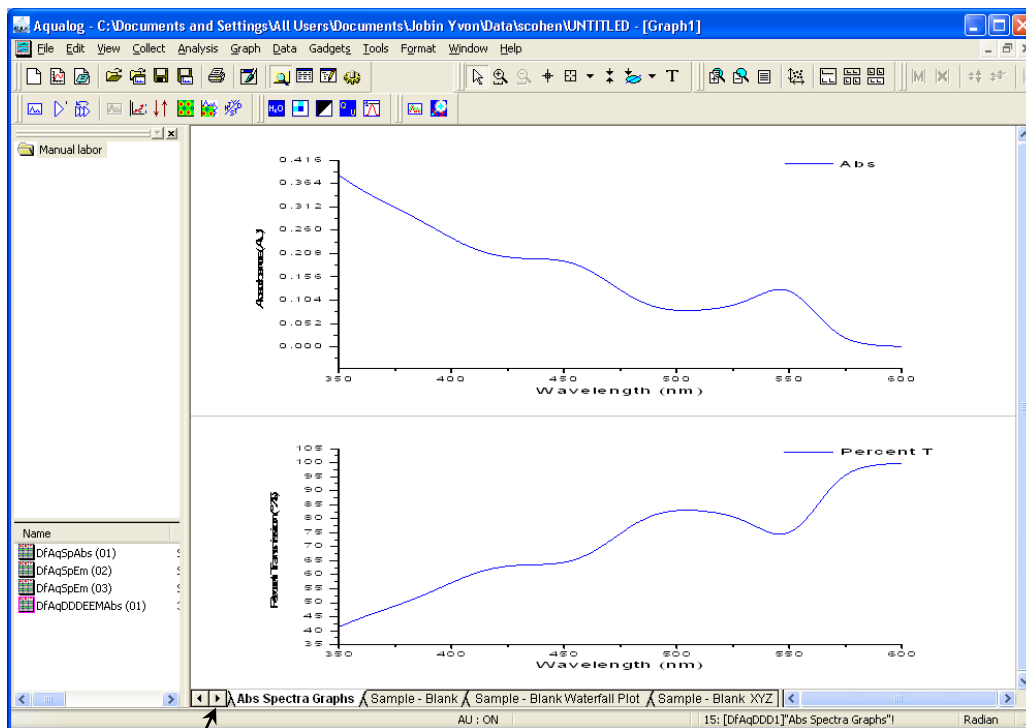

Click the ► button to find the Sample - Blank Contour Plot tab. Click the Sample - Blank Contour Plot tab to see a contour plot:

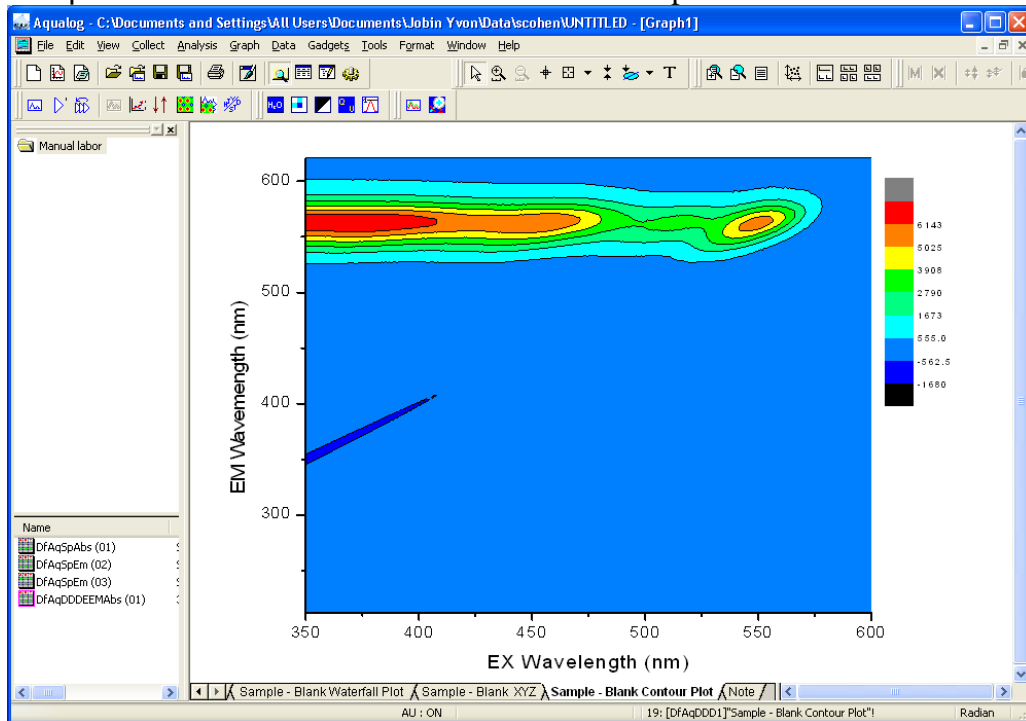

- 11 Return to the waterfall plot. In the toolbar, click the Aqualog IFE button  to remove inner-filter effects. (This calculation may take some time.)

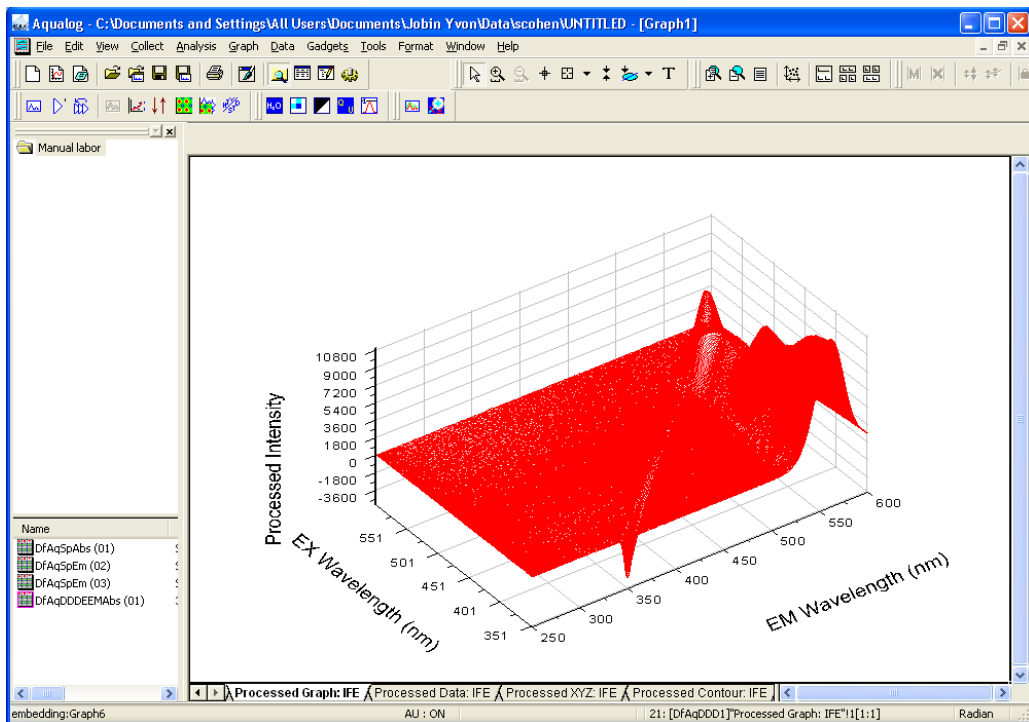

**Note:** The Aqualog IFE button only works with Sample-Blank waterfall plots from 3D emission + absorbance experiments.

- 12 In the toolbar, click the Rayleigh Masking button  to remove Rayleigh lines.



**Note:** The Rayleigh Masking button only works with waterfall plots.

The JY Rayleigh Masking User Input window appears.

- 13 Click the OK button.

Computer calculation may take some time. The masked spectral plot appears:

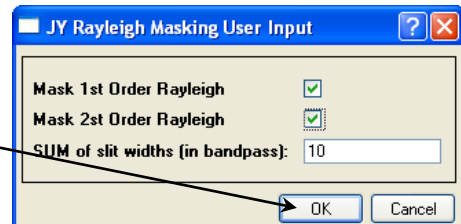

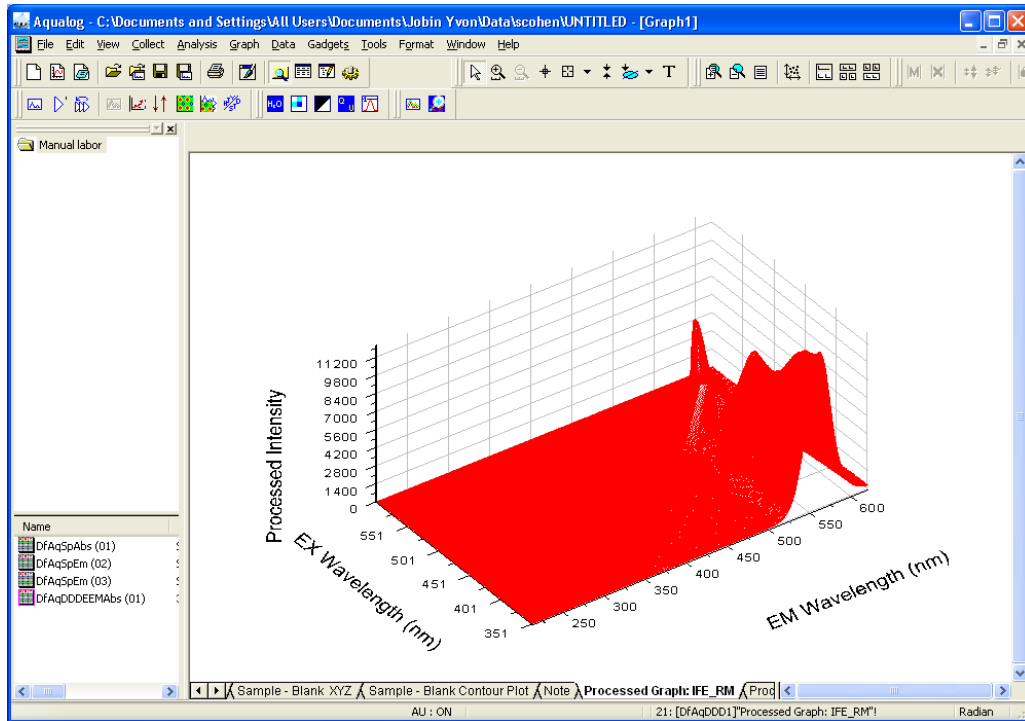

14 In the toolbar, click the Normalize button  to normalize the plot.

The **HJY\_normalize** window appears:

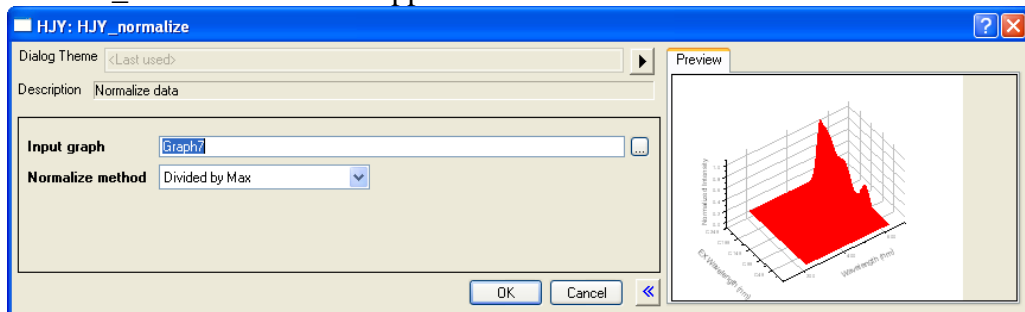

15 Click the OK button.

Computer calculation may take some time. The normalized waterfall plot appears:



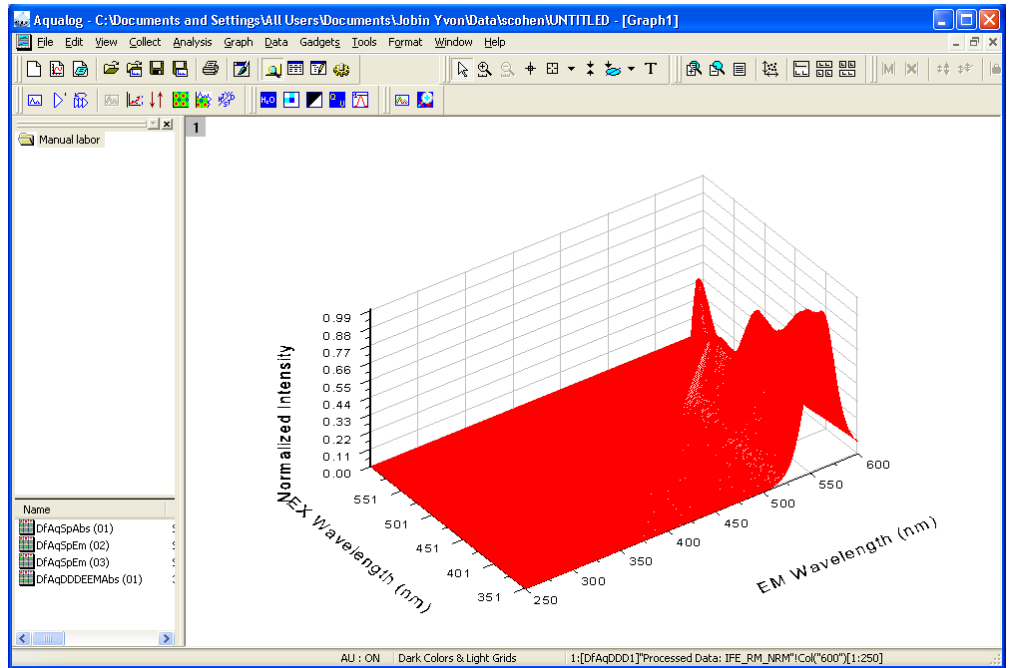

16 Click the appropriate tab to see the contour plot, which may be easier to interpret visually:

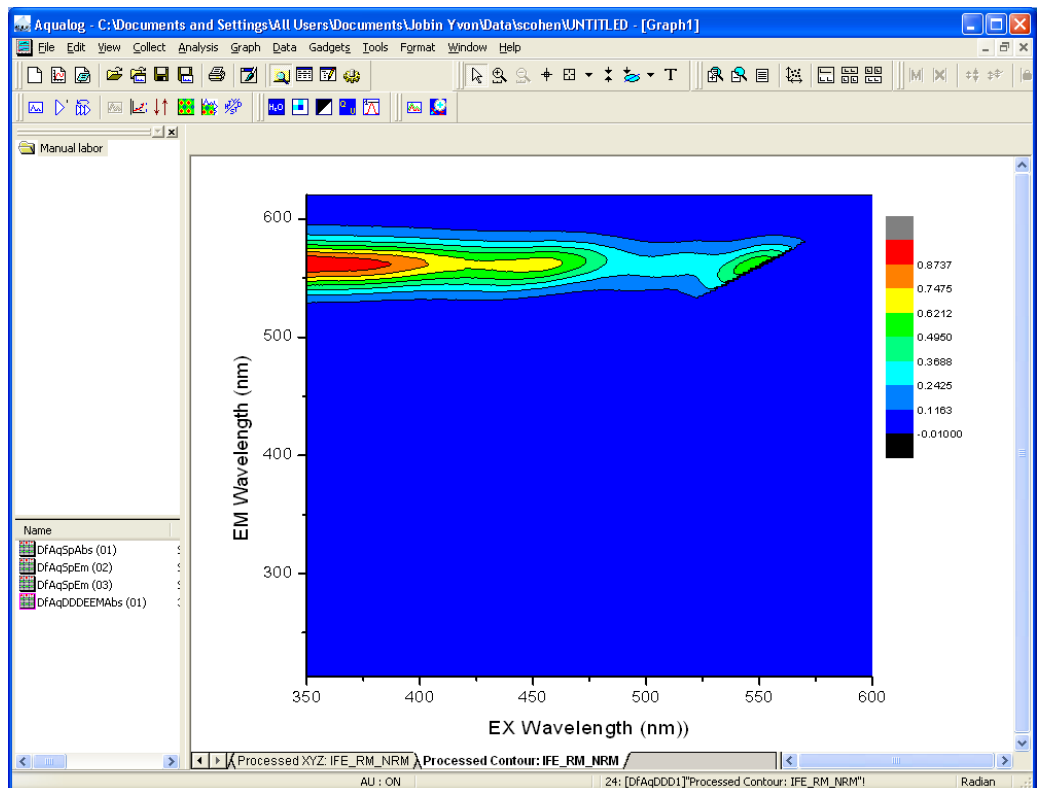

17 To examine profiles across the plot, in the toolbar click the Profile button.

Reminder messages appear.

# 18 Click the OK button.

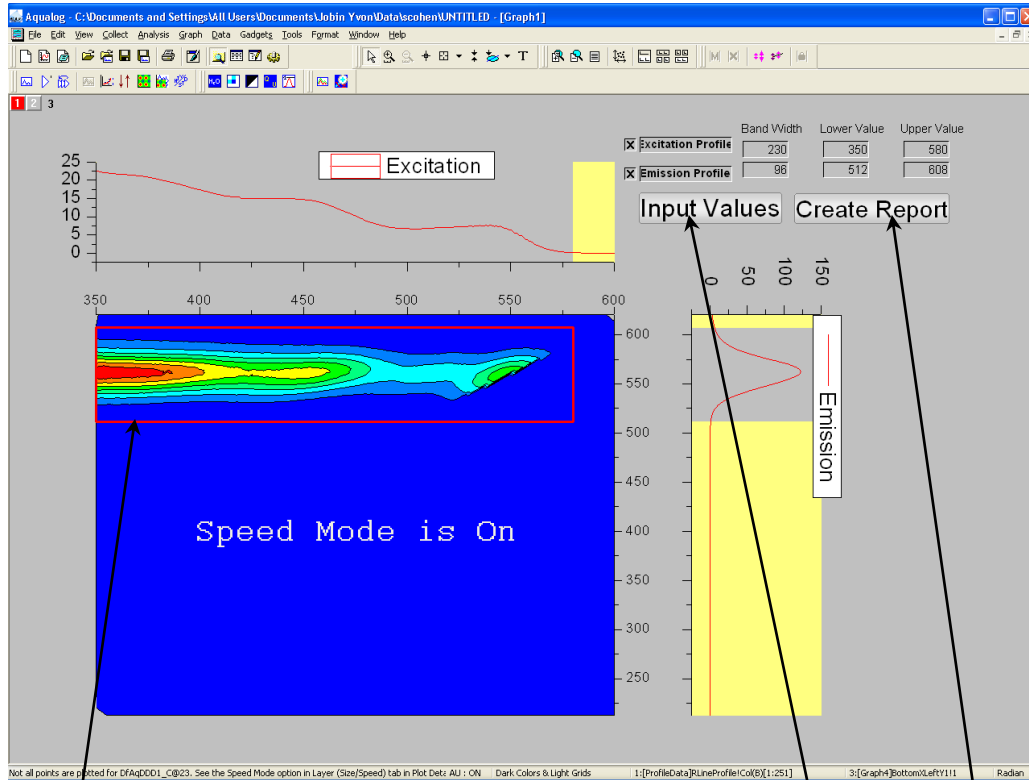

19 Move the boundaries of the red box to examine different cross-sections of the EEM, or click the Input Values button.

20 Use the Input Values window to enter manually the values of the cross-section.

21 Click the Create Report button.

A report appears:

Aqualog C:\Documents and Settings\All Users\Documents\Jobin Yvon\Data\scohen\UNTITLED - [Graph1]

File Edit View Collect Analysis Graph Data Gadgets Tools Format Window Help

Long Name A(X) B(Y) C(X) D(Y) E(Y) F(Y)  
 Units EX nm Excitation EM nm Excitation Emission  
 Comments Lower 350 511.56  
 Upper 580 607.58

Long Name	A(X)	B(Y)	C(X)	D(Y)	E(Y)	F(Y)
Units	EX nm	Excitation	EM nm	Excitation	Emission	
1	580	0.1762	511.609	0.91576		
2	579	0.18194	513.278	1.18949		
3	578	0.24318	514.947	1.53086		
4	577	0.26287	516.616	1.99046		
5	576	0.30698	518.286	2.5530		
6	575	0.39882	519.956	3.30413		
7	574	0.41193	521.627	4.27798		
8	573	0.50315	523.297	5.43276		
9	572	0.57431	524.968	6.94115		
10	571	0.69109	526.64	8.9151		
11	570	0.8536	528.311	10.93399		
12	569	0.89995	529.983	13.58768		
13	568	1.11408	531.656	16.80118		
14	567	1.18961	533.328	20.40789		
15	566	1.42619	535.001	24.79477		
16	565	1.74345	536.674	29.58993		
17	564	1.80049	538.348	34.97468		
18	563	2.18637	540.021	41.16781		
19	562	2.28844	541.695	47.78287		
20	561	2.67769	543.37	54.62249		
21	560	3.17779	545.044	62.46667		
22	559	3.26063	546.719	70.14551		
23	558	3.77922	548.394	77.84754		
24	557	3.8413	550.07	86.05435		
25	556	4.39229	551.746	93.4125		
26	555	4.94334	553.421	100.1911		
27	554	4.9264	555.098	107.10018		
28	553	5.47912	556.774	112.73662		
29	552	5.47455	558.451	117.69539		
30	551	5.96748	560.128	121.27801		
31	550	6.47487	561.805	122.51035		
32	549	6.41989	563.483	122.00666		
33	548	6.85973	565.161	120.30427		
34	547	6.73625	566.839	116.68226		
35	546	7.10617	568.517	111.54884		
36	545	7.45087	570.195	105.25211		
37	544	7.28223	571.874	97.15774		
38	543	7.57379	573.553	88.61037		
39	542	7.33964	575.233	79.23149		
40	541	7.59288	576.912	70.5633		
41	540	7.75218	578.592	62.28061		
42	539	7.50494	580.272	54.57731		
43	538	7.67838	581.952	47.39598		
44	537	7.38335	583.632	41.28637		

Processed Graph: IFE\_RM\_NRM / Processed Data: IFE\_RM\_NRM / Processed XYZ: IFE\_RM\_NRM / Processed Contour: IFE\_RM\_NRM / Profile /

AU : ON 25: [DfAqDD01]Profile Radon

# Kinetics spectra

This shows an example using quinine sulfate solution.

- 1 If you have an automatic sample-changer, place the blank and sample in the sample-changer. If you have a single-position sample-holder, place the blank in the sample compartment.
- 2 Close the cover of the sample compartment.
- 3 In the main window, click the Experiment Menu button .

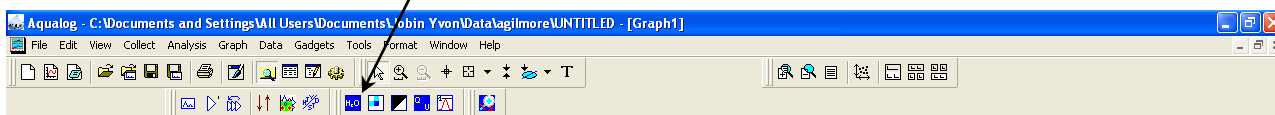

- 4 The **Aqualog Main Experiment Menu** opens.  
Click the Kinetics button.

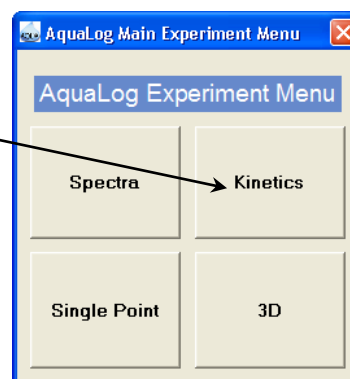

- 5 The **Aqualog Experiment Type** window opens.  
Choose the subtype of experiment, then click the Next >> button.

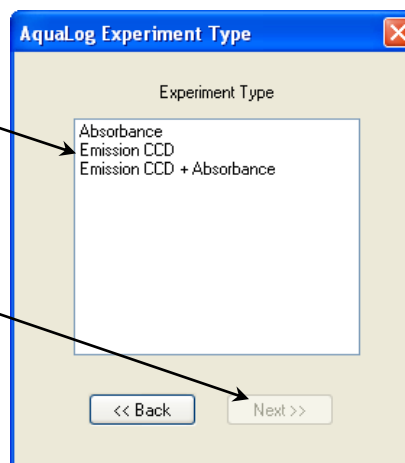

The **Aqualog Experiment Setup** window appears:

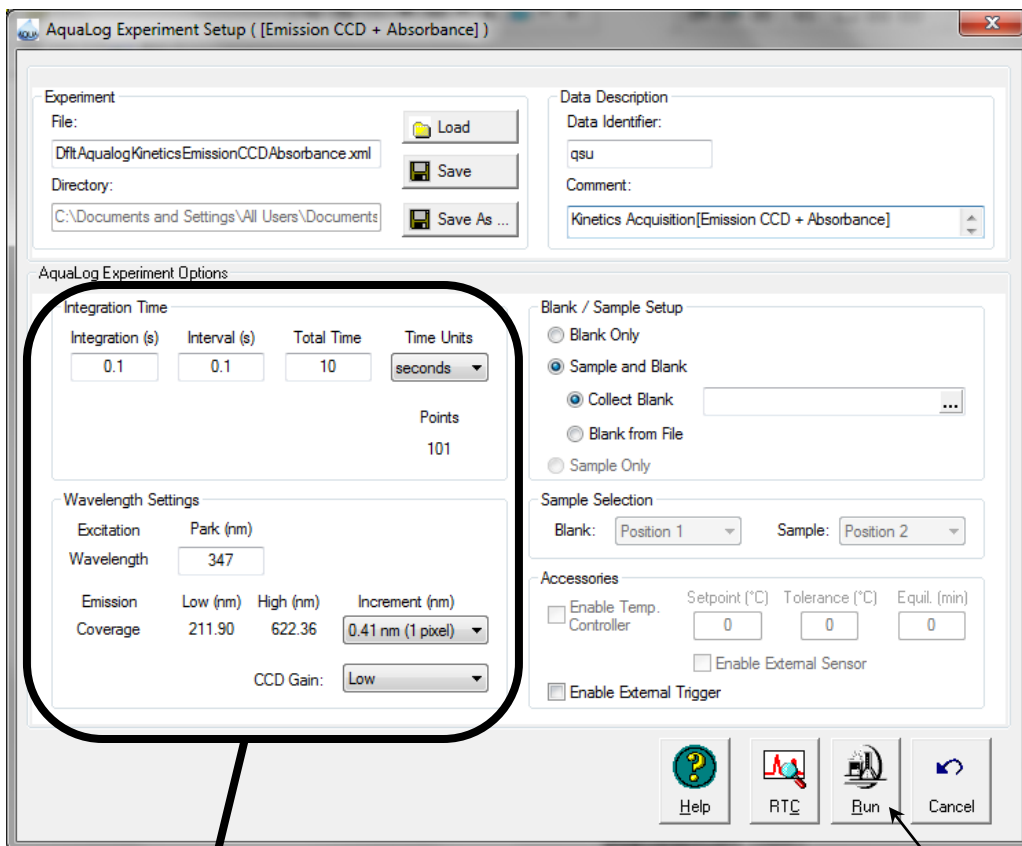

6 Set the experimental parameters, including Integration Time, Interval, Excitation Wavelength, Increment, and CCD Gain.



**Note:** For Kinetics experiments with the CCD, and the Interval Time is < 2 s, the Integration and Interval Times **must be equal**.

For Kinetics experiments with the CCD, and the Interval Time  $\geq 2$  s, the Interval Time may differ from the Integration Time. However, the Interval Time still must be equal to or greater than the Integration Time.

7 When all parameters are set, click the Run button.



The **Experiment Status** window appears. If you do not have an automatic changer, an **Experiment Paused** prompt to insert the blank (considered time = 0) appears:

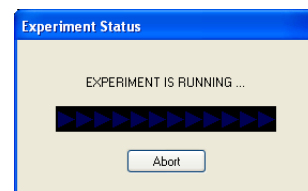

- 8 Insert the blank, close the sample-compartment lid, and click the OK button.

The scan continues. If you do not have an automatic changer, an **Experiment Paused** prompt to insert the sample appears.

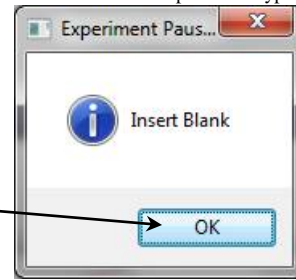

- 9 Insert the sample, close the sample-compartment lid, and click the OK button.

The **Project name** window appears when the scan is complete.

- 10 Click the Cancel button.

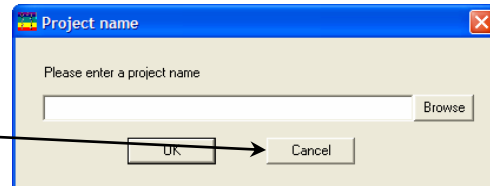

The final plot appears:

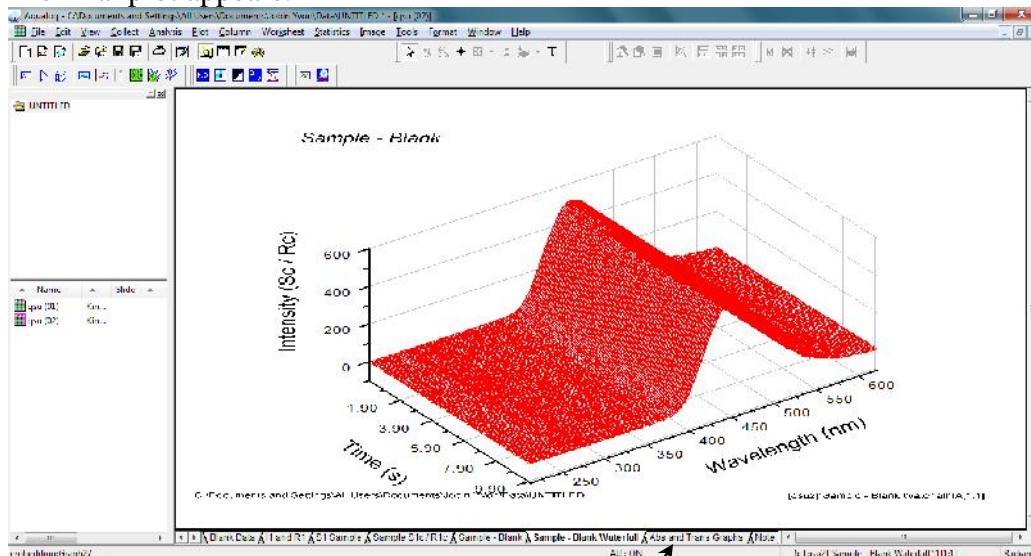

- 11 Choose the Abs and Trans Graphs tab to view the absorbance and transmission spectra.

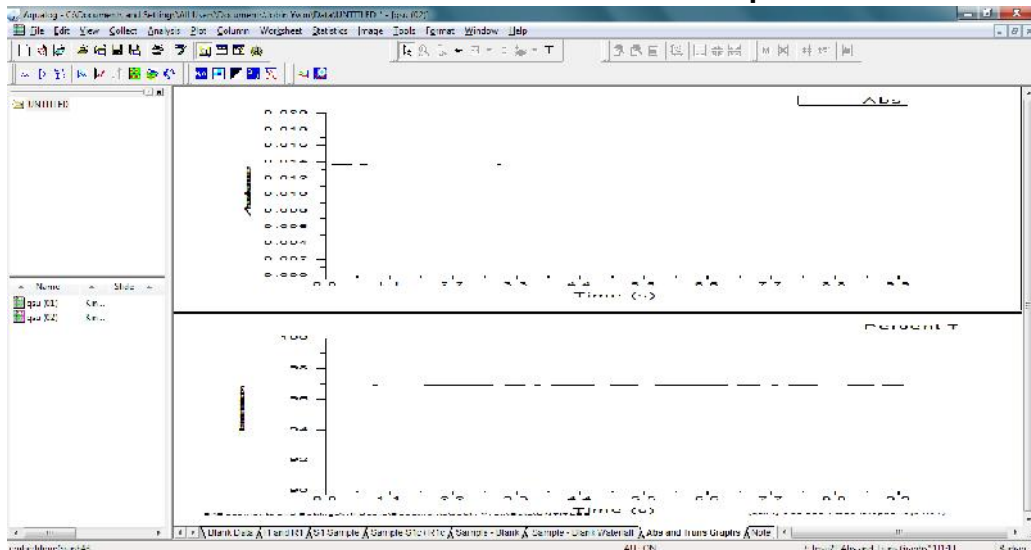

# Single-point spectra

This shows an example measuring quinine sulfate solution.



**Note:** Single-point spectra only use absorption mode.

- 1 If you have an automatic sample-changer, place the blank and sample in the sample-changer. If you have a single-position sample-holder, place the blank in the sample compartment.
- 2 Close the cover of the sample compartment.
- 3 In the main window, click the Experiment Menu button .

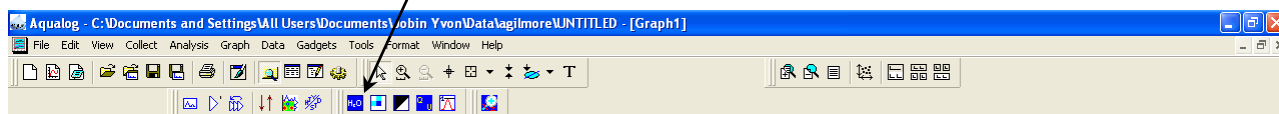

The **Aqualog Main Experiment Menu** opens.

- 4 Click the **Single Point** button.

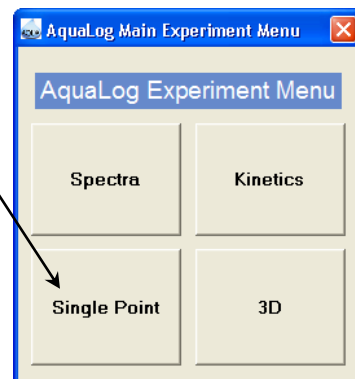

The **Aqualog Experiment Setup** window appears:

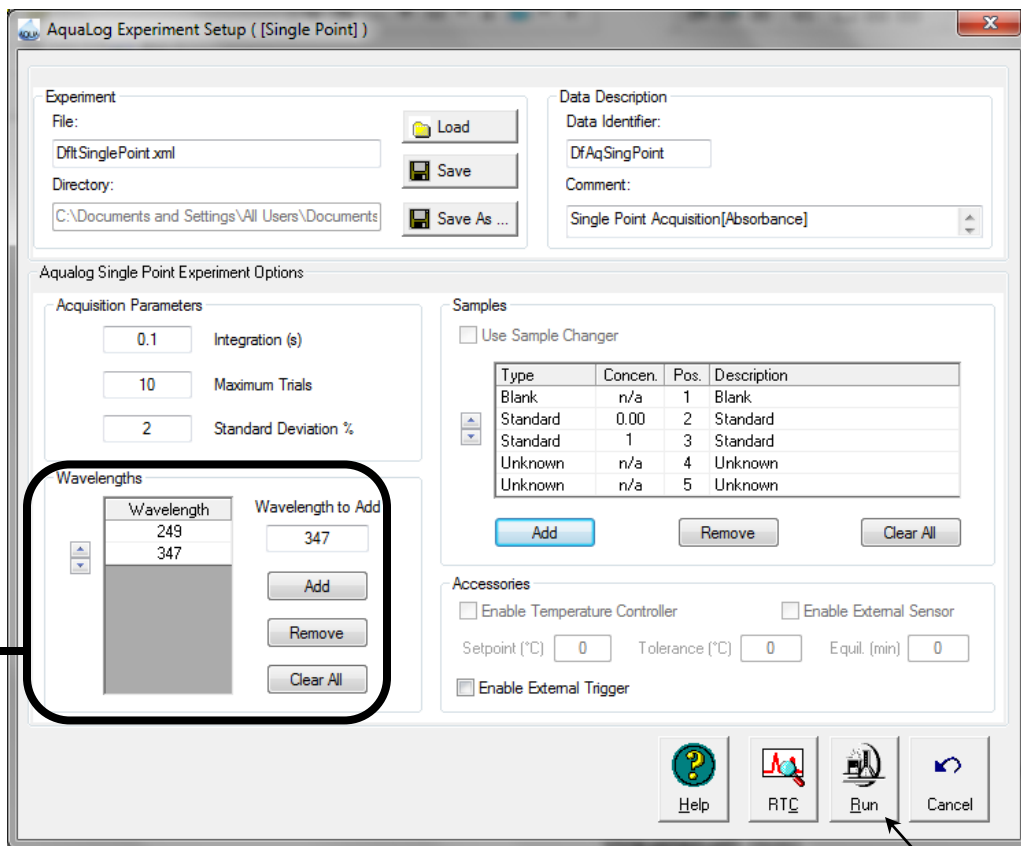

5 Set the experimental parameters.

a In the Wavelengths area, enter a wavelength (here we add 249), click the Add button to add it to the Wavelength list, and repeat (then add 347, and click the Add button) for more wavelengths at which to record absorbance.

b In the Samples area, create a list of samples to measure by clicking the Add button.

- The **Add Sample Types** window appears.
- Set the **Number of Standards** (here we enter 2) and **Number of Unknowns** (here we enter 2), then click the **OK** button. The **Samples** table is updated.
- In the new list of samples, enter concentrations and other labels. (Here, in the second **Standard** row, we enter 1, for 1 QSU.)

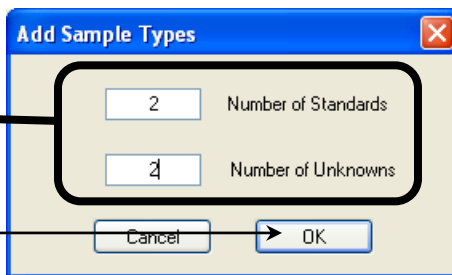

6 Click the Run button.

The software prompts you with the **Experiment Paused** window. In this case, the software asks for a Blank because a Blank is the first item in the **Samples** table.

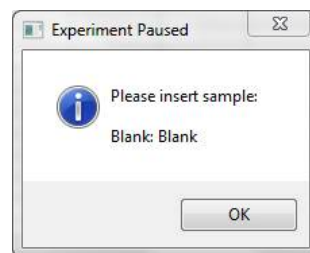



7 Put the blank in the sample compartment, close the lid of the sample compartment, and click the OK button.

The instrument runs through the list of samples sequentially, and prompts for the next sample, in this case, a Standard.

8 Insert that sample, close the lid, and click the OK button.

When all the samples have been scanned, the **Project name** window appears.

9 Click the Cancel button.

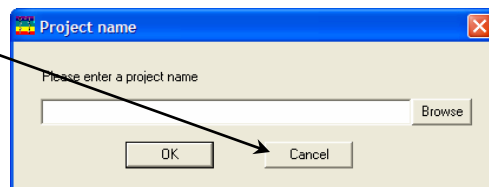

The final plot appears:

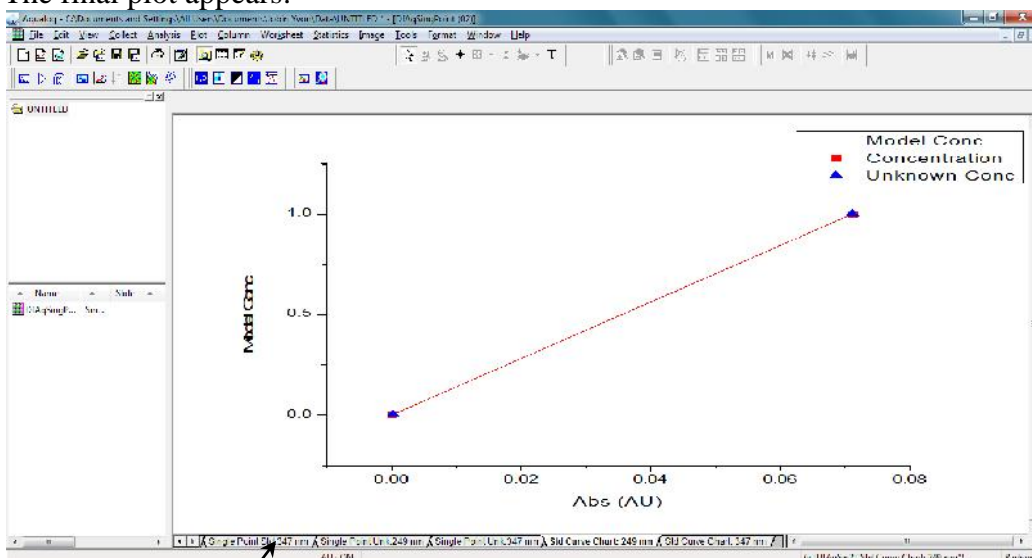

Note also, in the tabs at the bottom, a worksheet called **Single Point Std**. In this worksheet you find the Abs and Concentration columns. Here the model concentration is calculated; the linear regression provides the Slope of the line, Slope sd (standard deviation), Intercept of the line, and Intercept sd (standard deviation):



# Running an unknown sample

Often a researcher will scan a sample whose spectral characteristics are unknown. For optimal spectra, the optimal excitation and emission wavelengths must be found.

The optimal excitation wavelength is the wavelength that creates the most intense emission spectrum for a given sample. For many samples, the optimum wavelengths are known. For a sample whose wavelength positions are unknown, the user must determine these wavelengths to obtain the best possible results.

The traditional method consists of running an emission scan to find the peak emission value. Then an excitation scan is run using the determined peak emission value. In the Aqualog<sup>®</sup>, HORIBA Scientific has made this process much easier: perform a full three-dimensional absorbance scan, which includes all peaks.

- 1 If you have an automatic sample-changer, place the blank and sample in the sample-changer. If you have a single-position sample-holder, place the blank in the sample compartment.
- 2 Close the cover of the sample compartment.
- 3 In the main window, click the Experiment Menu button  button.

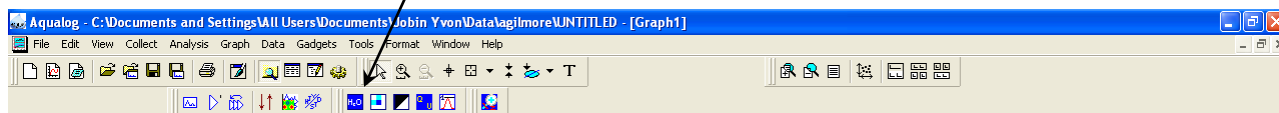

- 4 The **Aqualog Main Experiment Menu** opens.  
Click the 3D button.

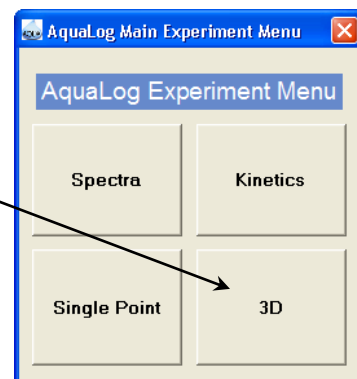

The **Aqualog Experiment Type** window opens.

5 Click EEM 3D + Absorbance, then click the Next >> button.

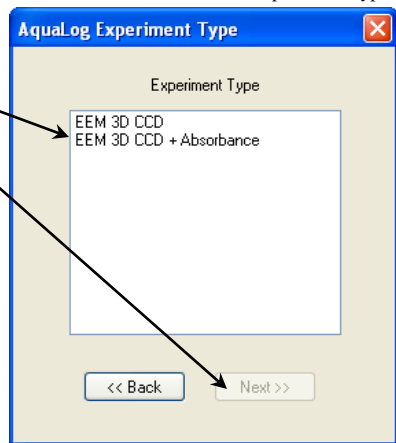

The **Aqualog Experiment Setup** window appears:

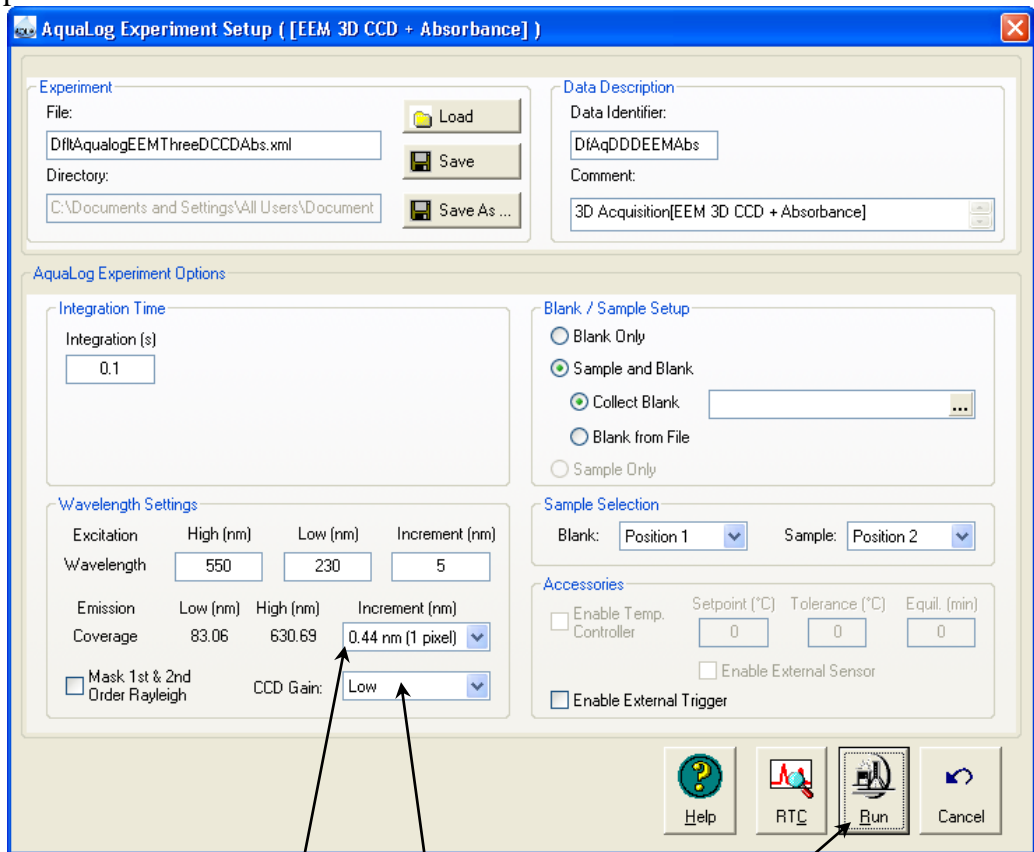

6 Set the experimental parameters.

- a To change the gain, in the CCD Gain drop-down menu, and choose the desired gain.
- b To change the pixel-binning, click the Increment drop-down menu.

7 Click the Run button  when all parameters are set.

The **Experiment Status** window appears.



If you have no automatic sample-changer, a prompt to insert the blank appears.

- 8 Insert the blank, close the sample-compartment cover, and click the OK button.



The scan continues. If you have no automatic sample-changer, a prompt to insert the sample appears.

- 9 Insert the sample close the sample-compartment cover, and click the OK button.

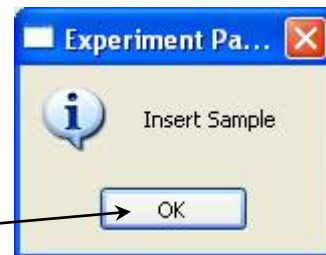

The **Intermediate Display** appears.

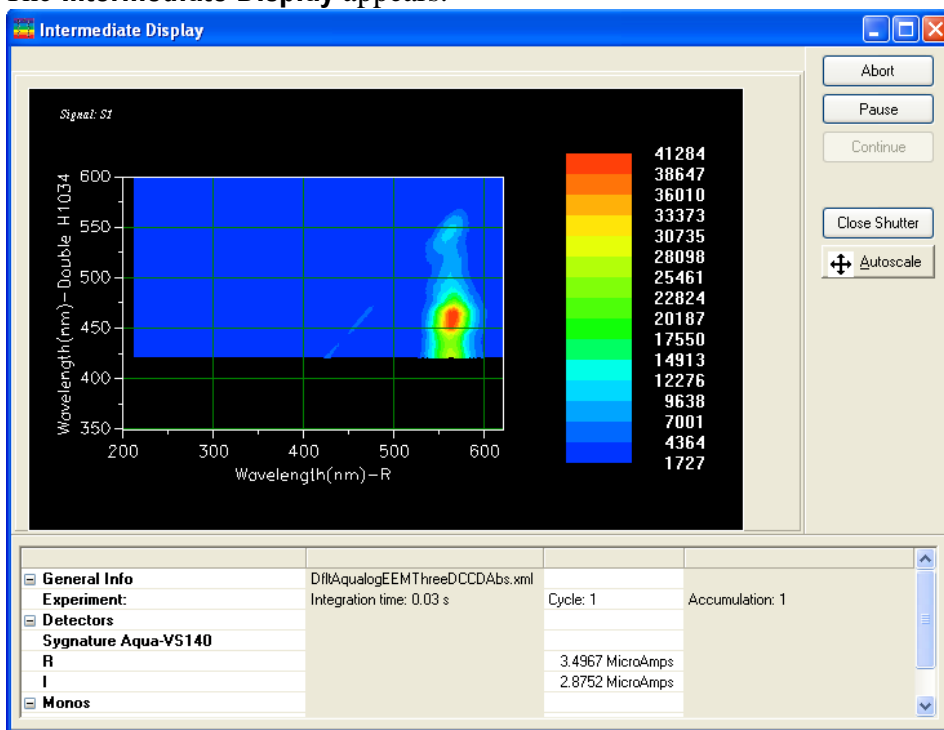

When the scan is complete, the emission spectrum appears. The dip in the spectra is the Rayleigh-band absorbance.

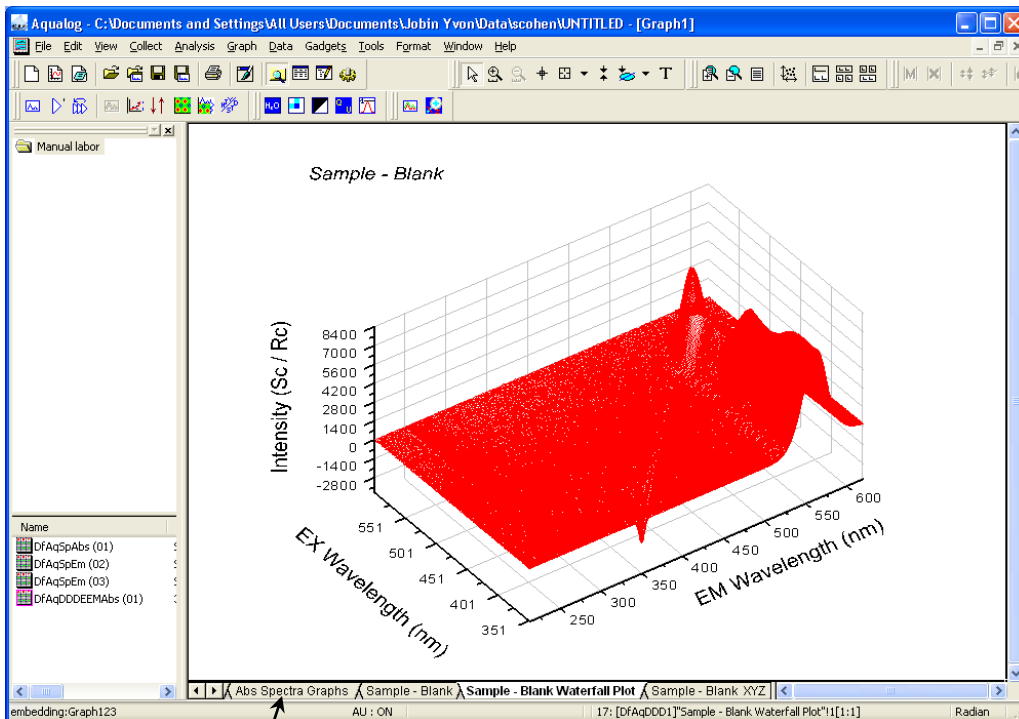

10 Click the Abs Spectra Graphs tab to see the absorption spectrum:

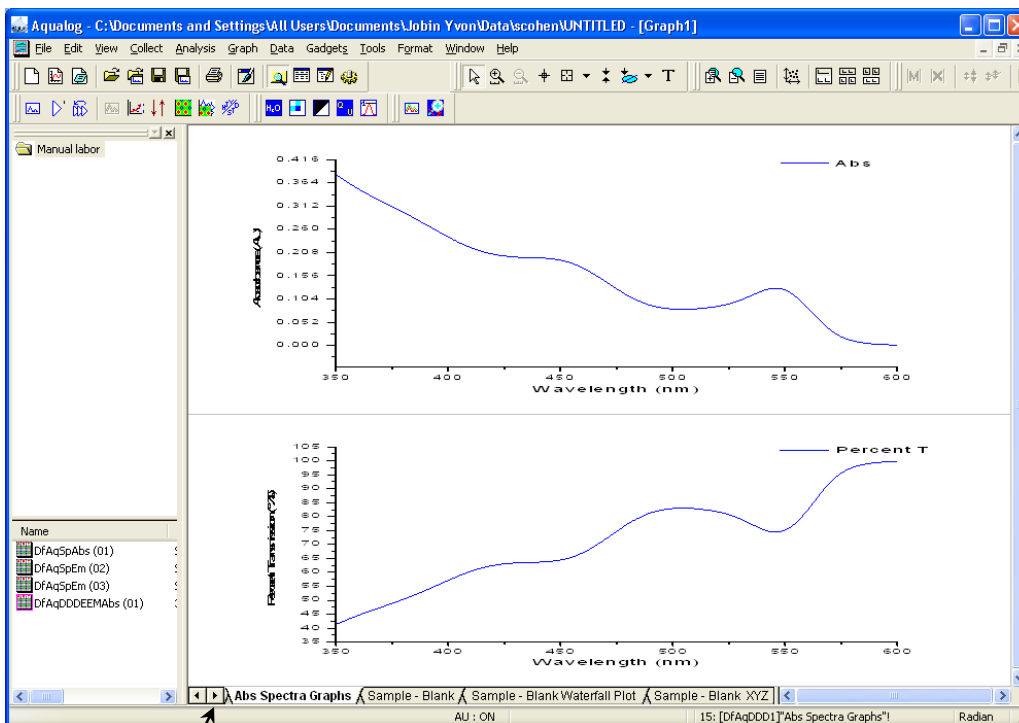

Click the ► button to find the Sample - Blank Contour Plot tab. Click the Sample - Blank Contour Plot tab to see a contour plot:

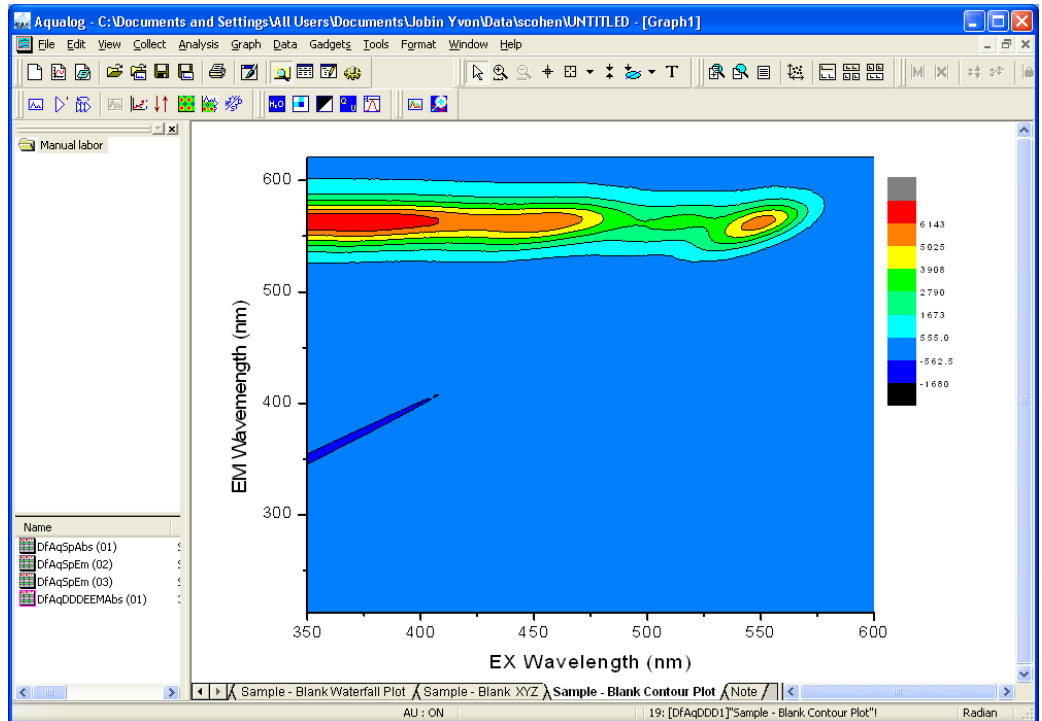

11 Return to the waterfall plot. In the toolbar, click the Aqualog IFE button  to remove inner-filter effects. (This calculation may take some time.)

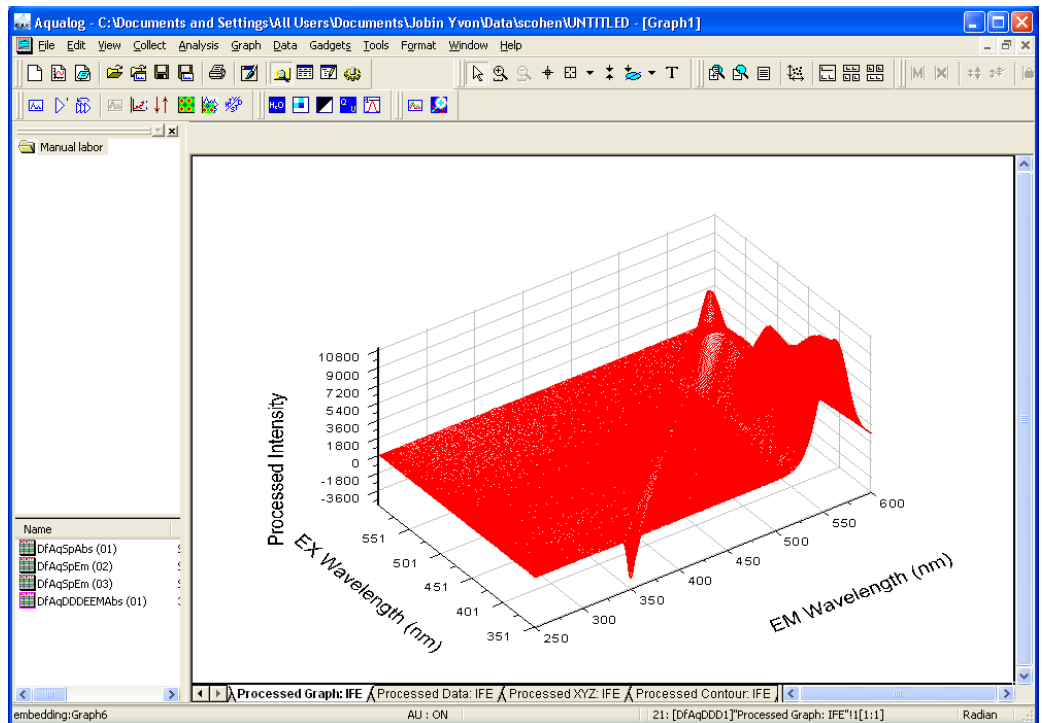

**Note:** The Aqualog IFE button only works with waterfall plots.

12 In the toolbar, click the Rayleigh Masking button  to remove Rayleigh lines.





*Note: The Rayleigh Masking button only works with waterfall plots.*

The JY Rayleigh Masking User Input window appears.

13 Click the OK button.

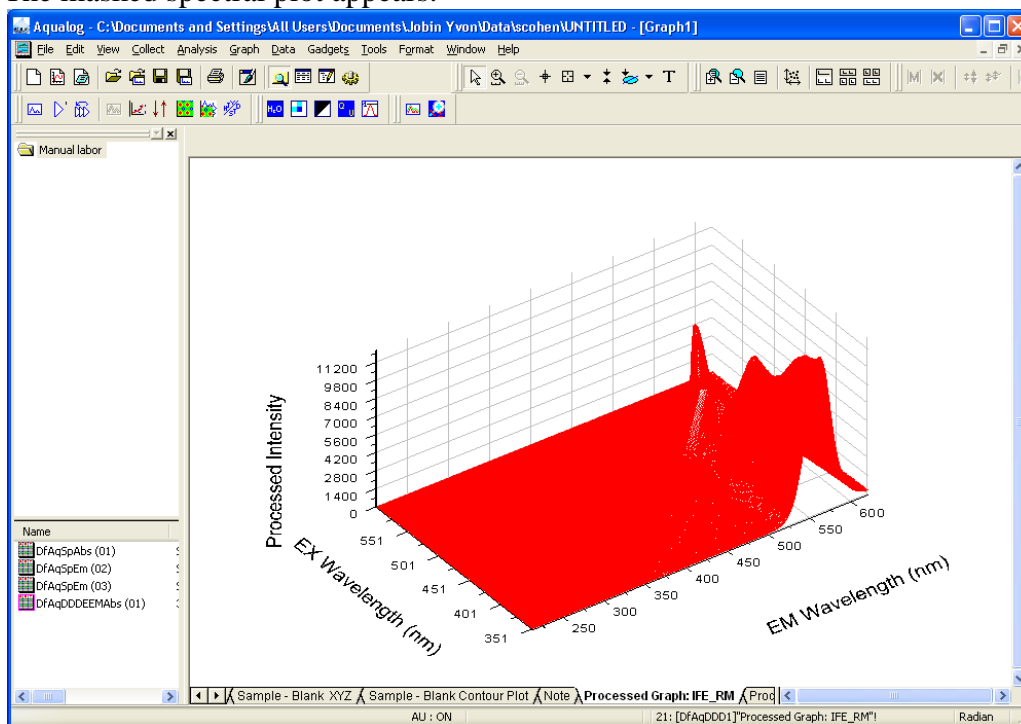
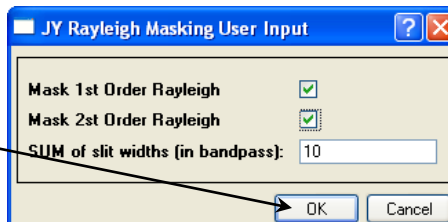
Computer calculation may take some time.  
The masked spectral plot appears:



14 In the toolbar, click the Normalize button  to normalize the plot.

The HJY\_normalize window appears:

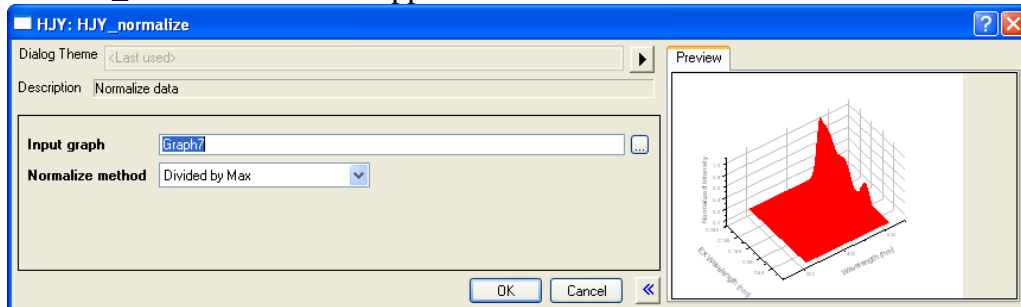



# 15 Click the OK button.

Computer calculation may take some time. The normalized waterfall plot appears:

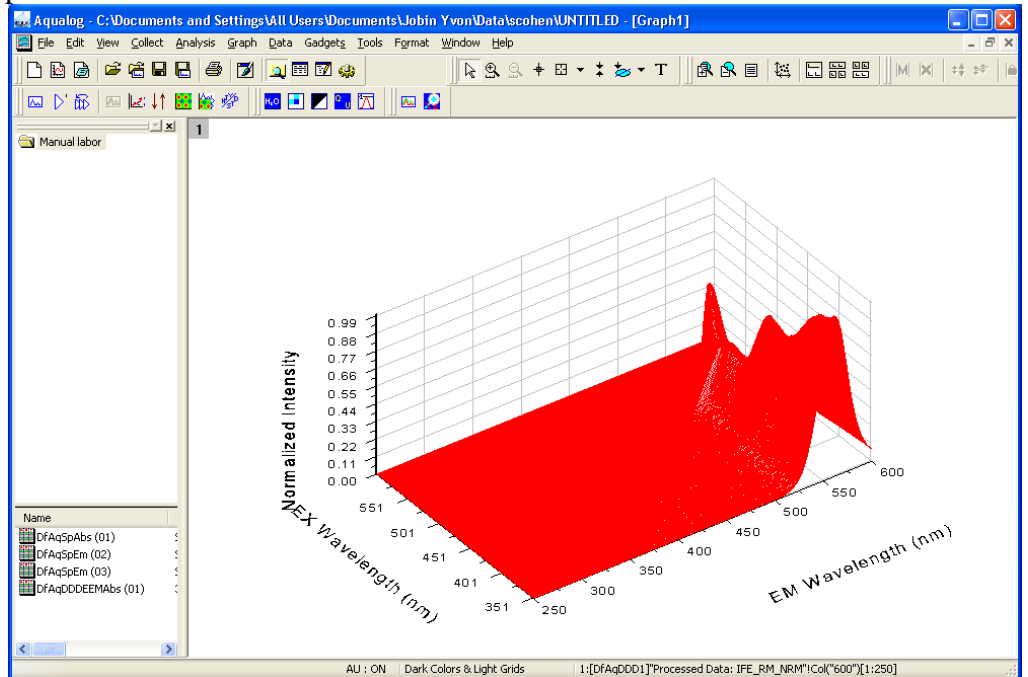

# 16 Click the appropriate tab to see the contour plot, which may be easier to interpret visually:

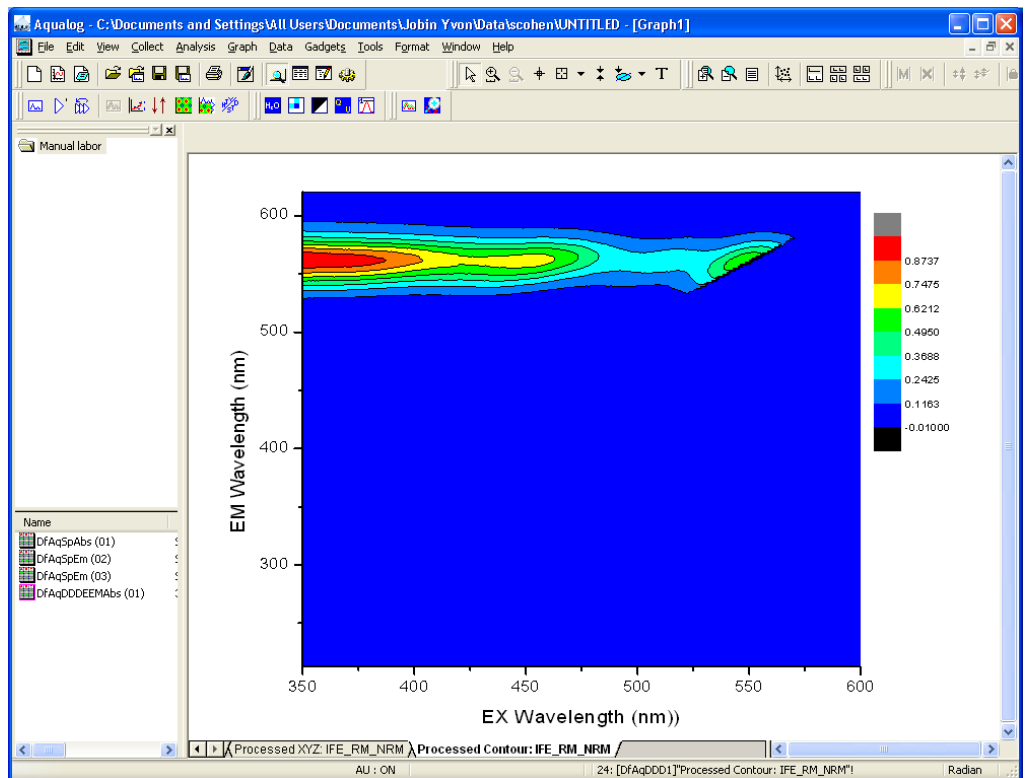

17 To examine profiles across the plot, in the toolbar click the Profile button.

Reminder messages appear.

18 Click the OK button.

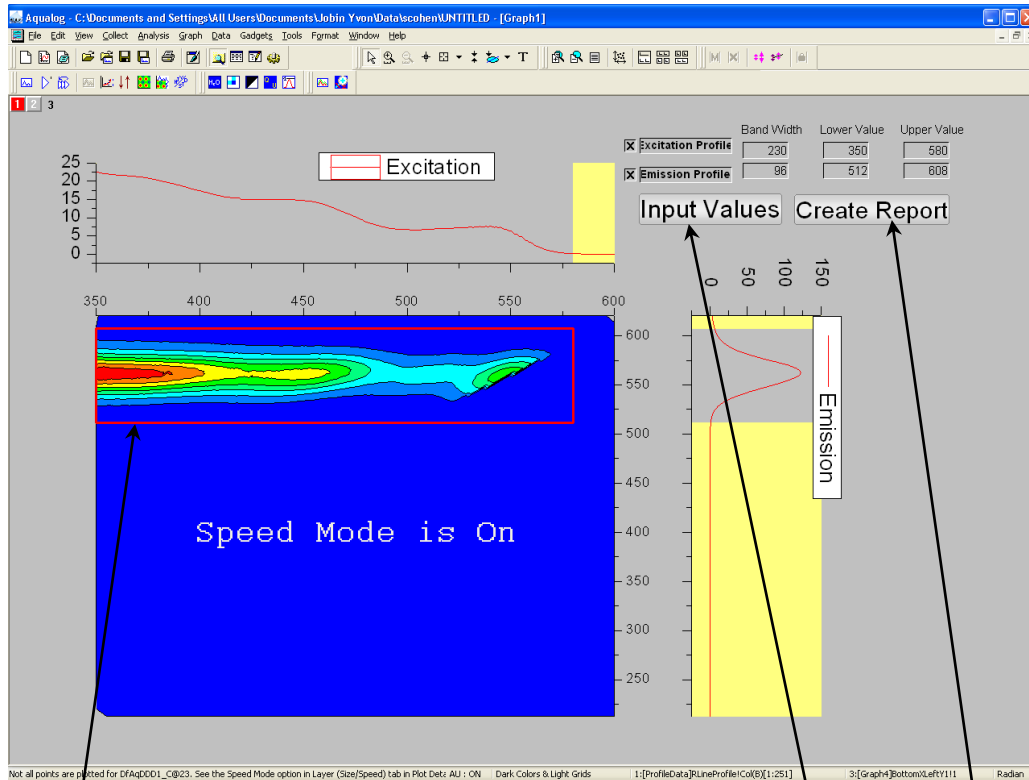

19 Move the boundaries of the red box to examine different cross-sections of the EEM, or click the Input Values button.

20 Use the Input Values window to enter manually the values of the cross-section.

21 Click the Create Report button.

A report appears:

Aqualog C:\Documents and Settings\All Users\Documents\Jobin Yvon\Data\scahen\UNTITLED - [Graph1]

File Edit View Collect Analysis Graph Data Gadgets Tools Format Window Help

Long Name A(X) B(Y) C(Z) D(V) E(Y) F(Y)  
 Units EX nm EM nm Excitation Emission  
 Comments  
 Lower 350 511.56  
 Upper 580 607.58

Long Name	A(X)	B(Y)	C(Z)	D(V)	E(Y)	F(Y)
1	580	0.1762	511.609	0.91576		
2	579	0.18194	513.278	1.18949		
3	578	0.24318	514.947	1.53086		
4	577	0.26297	516.616	1.99046		
5	576	0.30698	518.286	2.5530		
6	575	0.39882	519.956	3.30413		
7	574	0.41193	521.627	4.27798		
8	573	0.50315	523.297	5.43276		
9	572	0.57431	524.968	6.94115		
10	571	0.69109	526.64	8.9151		
11	570	0.8536	528.311	10.93399		
12	569	0.89995	529.983	13.58768		
13	568	1.11408	531.656	16.80118		
14	567	1.18961	533.328	20.40799		
15	566	1.42619	535.001	24.79477		
16	565	1.74345	536.674	29.58993		
17	564	1.80049	538.348	34.97468		
18	563	2.18637	540.021	41.16781		
19	562	2.28944	541.695	47.78287		
20	561	2.87769	543.37	54.62249		
21	560	3.17779	545.044	62.46667		
22	559	3.26663	546.719	70.14551		
23	558	3.77922	548.394	77.84754		
24	557	3.8413	550.07	86.05435		
25	556	4.39229	551.746	93.4125		
26	555	4.94334	553.421	100.1911		
27	554	4.9264	555.098	107.10018		
28	553	5.47912	556.774	112.73662		
29	552	5.47455	558.451	117.66539		
30	551	5.98748	560.128	121.27901		
31	550	6.47487	561.805	122.51035		
32	549	6.41989	563.483	122.00666		
33	548	6.85973	565.161	120.30427		
34	547	6.73625	566.839	116.68226		
35	546	7.10617	568.517	111.54894		
36	545	7.45087	570.195	105.25211		
37	544	7.28223	571.874	97.15774		
38	543	7.57379	573.553	88.61037		
39	542	7.33964	575.233	79.23149		
40	541	7.59288	576.912	70.5633		
41	540	7.75218	578.592	62.28061		
42	539	7.50494	580.272	54.57731		
43	538	7.67838	581.952	47.39598		
44	537	7.38335	583.632	41.28637		

Processed Graph: IFE\_RM\_NRM / Processed Data: IFE\_RM\_NRM / Processed XYZ: IFE\_RM\_NRM / Processed Contour: IFE\_RM\_NRM / Profile / AU : ON 25: [DfAqDD01]Profile! Radon



# 7: Troubleshooting

The Aqualog<sup>®</sup> system has been designed to operate reliably and predictably. If there is a problem, examine the chart below, and try the steps on the following pages.

<b>Problem</b>	<b>Possible Cause</b>	<b>Remedy</b>
<b>Light is not reaching the sample.</b>	Monochromator is miscalibrated.	Check and recalibrate monochromator.
	Sample turret is not in correct position.	Using Aqualog <sup>®</sup> software, set the position and open the cover to verify the position.
<b>Signal intensity is low.</b>	CW lamp is not aligned.	Align the lamp.
	Shutter(s) is(are) not completely open.	Open the shutter(s) in <b>Real Time Control</b> .
	Lamp power-supply is set to the wrong current rating.	Call the Service Department.
	Lamp is too old.	Replace lamp. (150-W lamp has lamp lifetime 1200–1500 h.)
	Shutter(s) closed.	Open all shutters in <b>Real Time Control</b> .
	Not enough signal at the detector.	Increase the CCD gain in the drop-down menu in the <b>Experiment Setup</b> window; increase the integration time; increase the number of accumulations.
<b>Signal intensity is at least 10 times lower than normal.</b>	Monochromators are set to wrong wavelength.	Select appropriate wavelength based on excitation and emission of sample.
	Detectors are saturated.	(Signal detector is linear to 65 535 counts. Reference detector saturates at 200 $\mu$ A.) Sample is too concentrated. Dilute sample by a factor of 10 or 100 and retry experiment.
	Optical density effects and self-absorption.	Sample is too concentrated. Dilute sample by a factor of 10 or 100 and retry experiment.
<b>Signal intensity reaches 65 535 (maximum).</b>	CCD detector is saturated.	Sample is too concentrated. Dilute sample by a factor of 10 or 100 and retry experiment. Shorten integration time. Reduce CCD gain. Check

		that the absorbance is linear with concentration.
<b>No signal.</b>	Lamp is not on.	Bad lamp: change xenon lamp.
	No sample is in sample compartment.	Place sample in the sample compartment.
	CCD detector has failed.	Call Service Department.
<b>Erratic signal.</b>	Lamp unstable.	Let lamp warm up 20 min before use Replace lamp Replace power supply Check electronics board(s)
	Light leaks.	Check dark value to determine.
	Sample has particles that scatter light irregularly.	Filter sample, or let particles settle before running scan.
	Temperature of instrument outside of specified operation range	
<b>Large off-scale peak at twice the excitation wavelength.</b>	Second-order effects from the instrument.	Use Rayleigh-masking tool to eliminate 2 <sup>nd</sup> -order peak.
<b>Stray light in emission scan (also see example in this chapter).</b>	Dirty cuvette.	Clean the cuvette as described in Chapter 8.
	Solid-sample holder in sample compartment.	Rotate the holder to prevent direct scatter from entering the emission spectrograph.
<b>Corrected excitation spectrum curves upward ~240–270 nm.</b>	Dark count is divided by low reference signal.	Use <b>Dark Offset</b> checkbox; retry scan.
<b>Noisy spectrum with magnetic stirrer.</b>	Stirring speed is too fast.	Use slower stirring speed.
	Stirring bar is too large; light beam is striking it.	Use a smaller stirring bar (available from Bel-Art Products, Pequannock, NJ).
<b>Communication problems between</b>	USB cable is improperly connected.	Check USB cable's connection.

<b>computer and instrument.</b>	Problem with the USB port on the host computer.	Change the USB cable to a new port; restart the host computer.
<b>Hardware Init. Error appears.</b>	Broken IR sensor in monochromator.	Replace IR sensor: Call Service Department.
<b>Sample turret is not operating.</b>	Software is not enabled. USB cable is connected improperly.	Check status. Check USB cable's connection.
<b>“Data file does not exist” or “file read error” message appears.</b>	User is not logged into Windows <sup>®</sup> XP as administrator or power user.	Log into Windows <sup>®</sup> XP as administrator and or power user, and restart Aqualog <sup>®</sup> software
<b>Validation test fails.</b>	Problem with the sample.	Confirm that the correct standard is inserted with the proper orientation; confirm that the standard cuvette is clean.
<b>Small discontinuity in absorption data at ~410 nm.</b>	Filter-wheel is not moving properly.	Call Service Department.

## Further assistance...

Read all software and accessory manuals before contacting the Service Department. Often the manuals show the problem's cause and a method of solution. Technical support is available for both hardware and software troubleshooting.

Before contacting the service department, however, complete the following steps.

- 1 If this is the first time the problem has occurred, try turning off the system and accessories.

After a cool-down period, turn everything back on.

- 2 Make sure all accessories are properly configured, and turned on as needed.

- 3 Following the instructions in Chapter 4, System Operation, run the verification tests to make sure the system is properly calibrated.

Print the spectrum or table for each and note the peak intensities.

- 4 Check this chapter to see if the problem is discussed.

- 5 Try to duplicate the problem and write down the steps required to do so.

The service engineers will try to do the same with a test system. Depending on the problem, a service visit may not be required.

- 6 If an error dialog box appears in the Aqualog<sup>®</sup> software, write down the exact error displayed.

- 7 In the Aqualog<sup>®</sup> software, in the **Aqualog** main window's toolbar, choose Help:

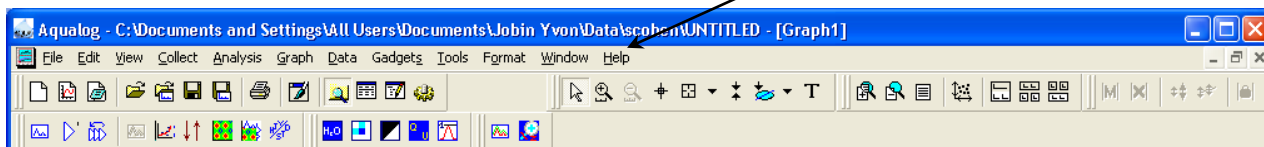

A drop-down menu appears.

- 8 Under Help, choose About Aqualog....

This opens the **About Aqualog** window:



The version of the software (both Aqualog<sup>®</sup> and Origin<sup>®</sup>) is listed here.



9 Click the View System Info button.

The **Installed Components** window appears, displaying all the software required for Aqualog<sup>®</sup> software.

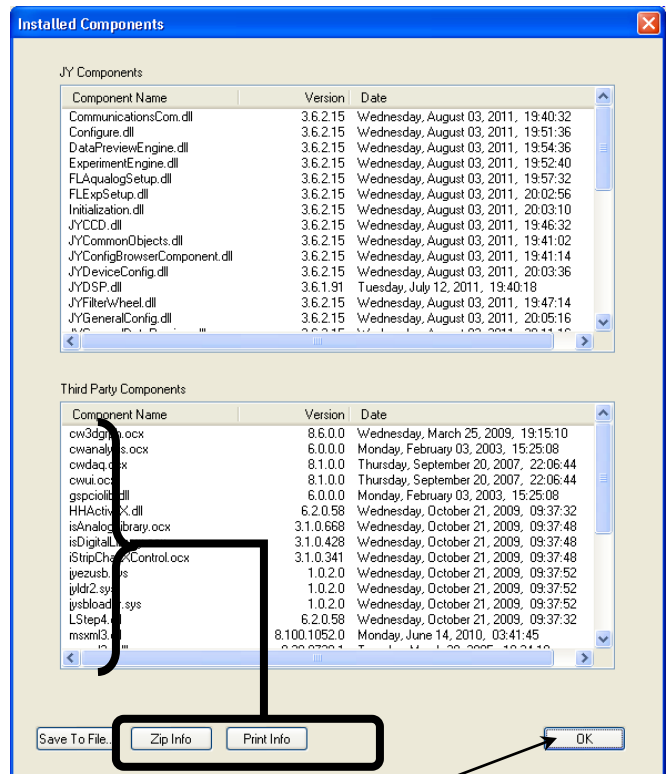

10 Record the information by clicking the:

- Save To File... button, which saves the information to a file;
- Zip Info button, which compresses the information while saving it;
- Print Info button, which prints out the software information.

11 Click the OK button to close the **Installed Components** window.

12 Click the OK button to close the **About Aqualog** window.

13 Write down the software's version numbers, along with the purchase dates, model numbers,

system configuration, and serial numbers of the instrument and its accessories.

## 14 Determine the SpectrAcq firmware version:

- a Open the **Experiment Setup** window.

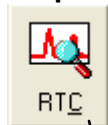

- b Click the RTC button to enter the **Real Time Control**.

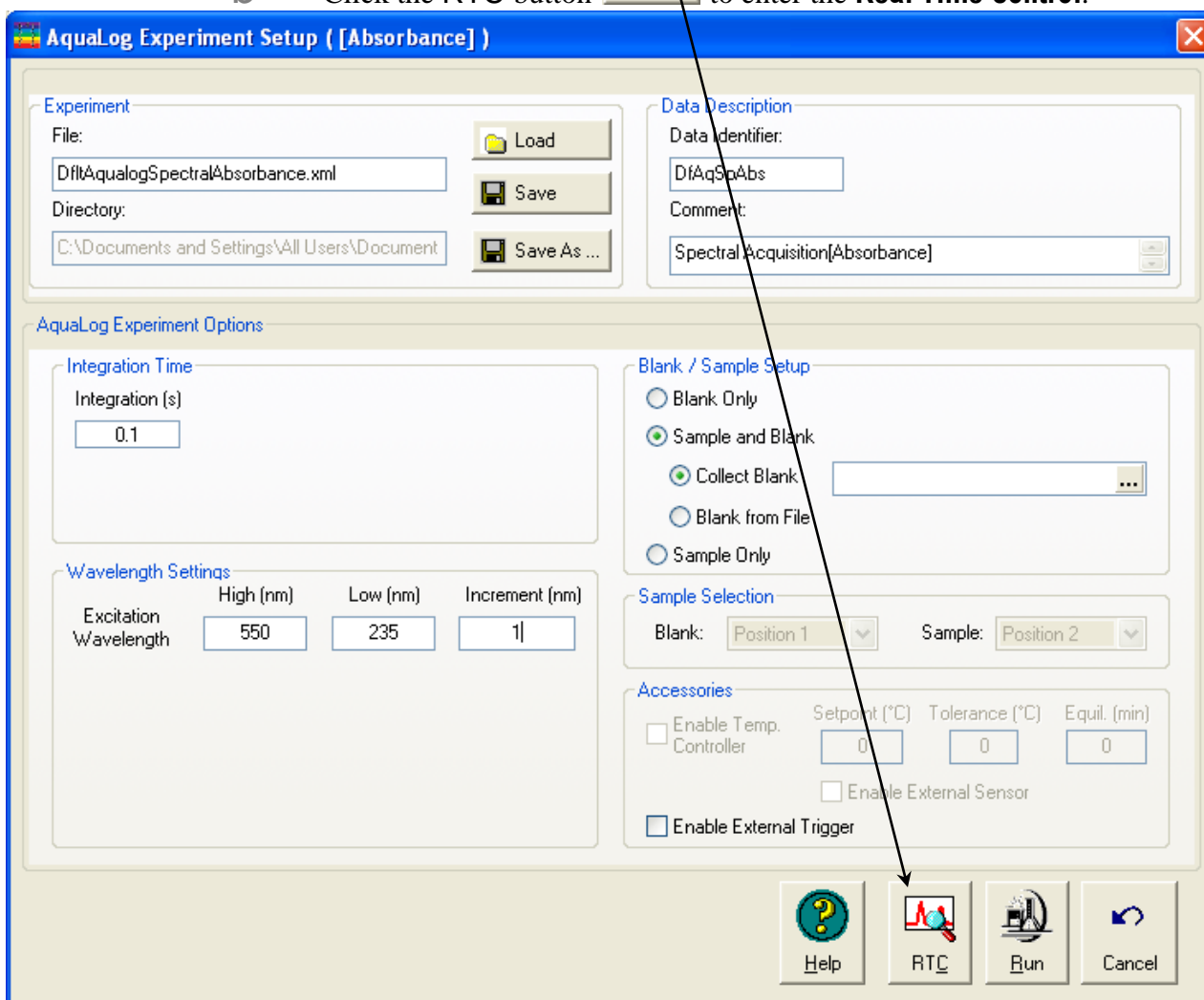

The **Real Time Control** appears:

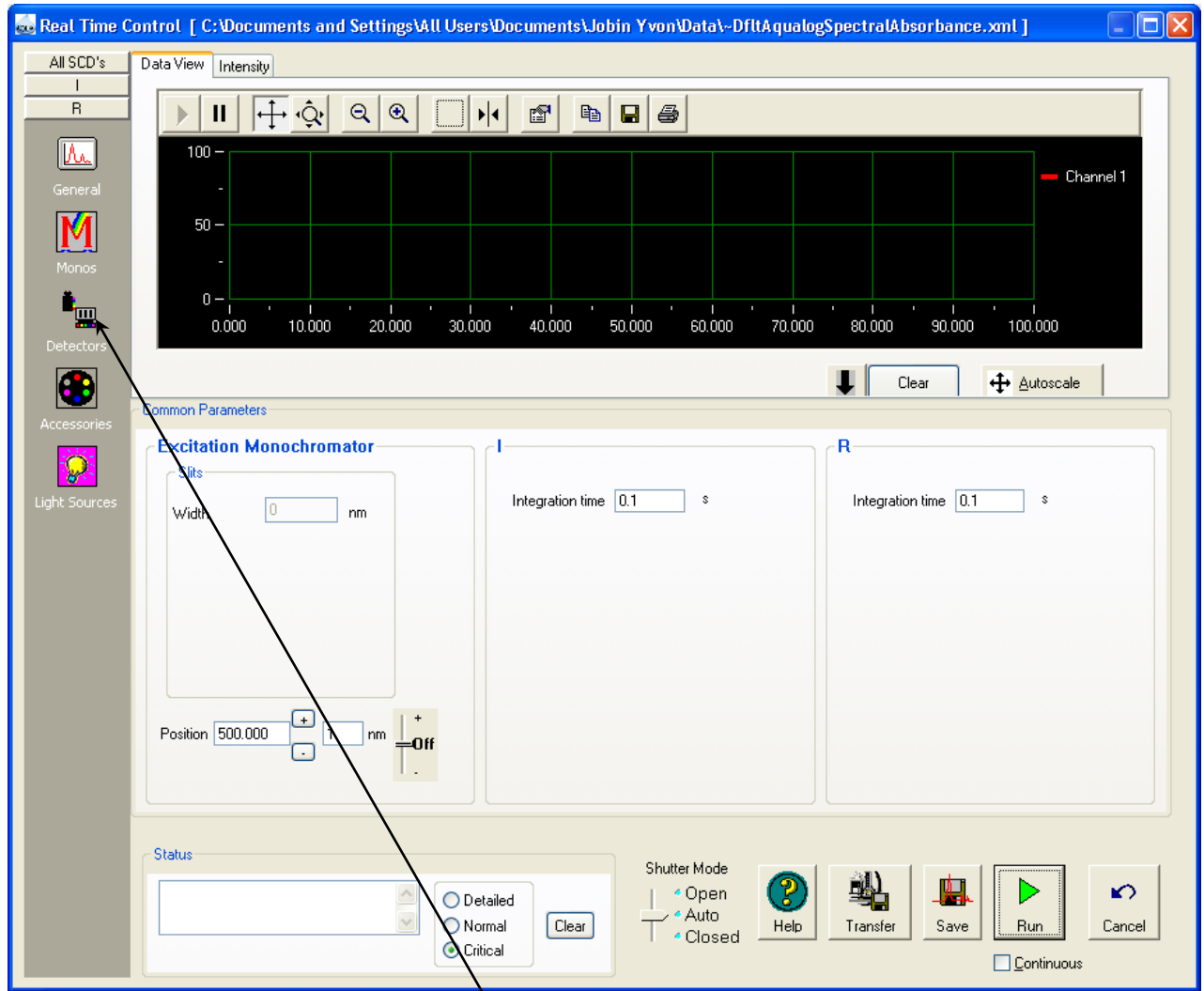

C Click the Detectors icon.

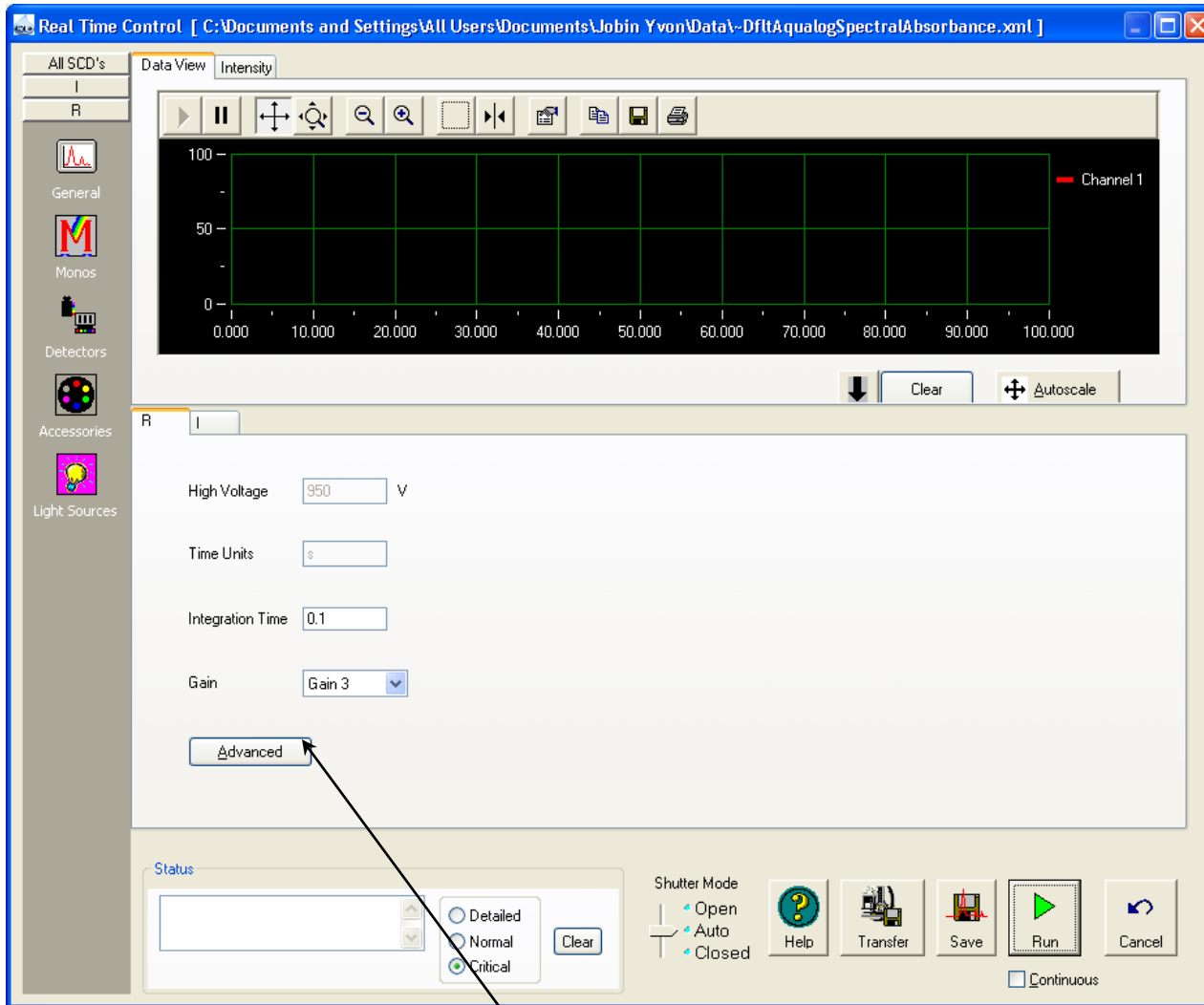

d Click the Advanced button.  
The **Single Channel Advanced Parameters** window appears.

e Write down the Device Id field.

f Click the OK button to close the window.

If the problem persists or is unlisted, call the Service Department at (877) 546-7422.

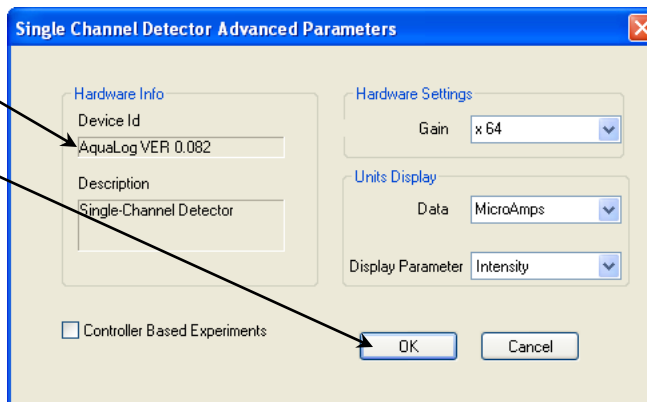

# 8: Modeling with Solo

## Introduction

The Aqualog<sup>®</sup> generates excitation-emission matrices that are fully corrected and treated, for immediate analysis using the multivariate toolbox from our partner, Eigenvector, Inc.'s Solo software package. This chapter explains the operations associated with three major tools for evaluating the identities and quantities of components of your mixture:

- Parallel-Factor Analysis (PARAFAC)
- Principal-Components Analysis (PCA)
- Classical Least-Squares Analysis (CLS)

Each of these tools is described, starting from importing a file, through pre-processing data, fitting and evaluating the model, and generation of a report.

In addition, if you want to compare the internal consistency of a dataset, use the Split Half Analysis function.

You can use the Solo software package for evaluating the data with conventional collection and export schemes from the Aqualog<sup>®</sup> software, and also the Sample Queue tool.

For detailed explanations of theory and operation of the Solo package, please see the website [www.eigenvector.com/software/solo.htm](http://www.eigenvector.com/software/solo.htm) .

# Using PARAFAC



*Note: Though theoretically you can attempt to deconstruct a mixture with many, many components using PARAFAC, HORIBA recommends only a practical maximum of six components.*

## 1 Start the PARAFAC modeling method.

- a On the host computer's desktop, click the Solo icon. The software may take a while to load. Be patient until the **Solo+MIA Workspace Browser** window appears:

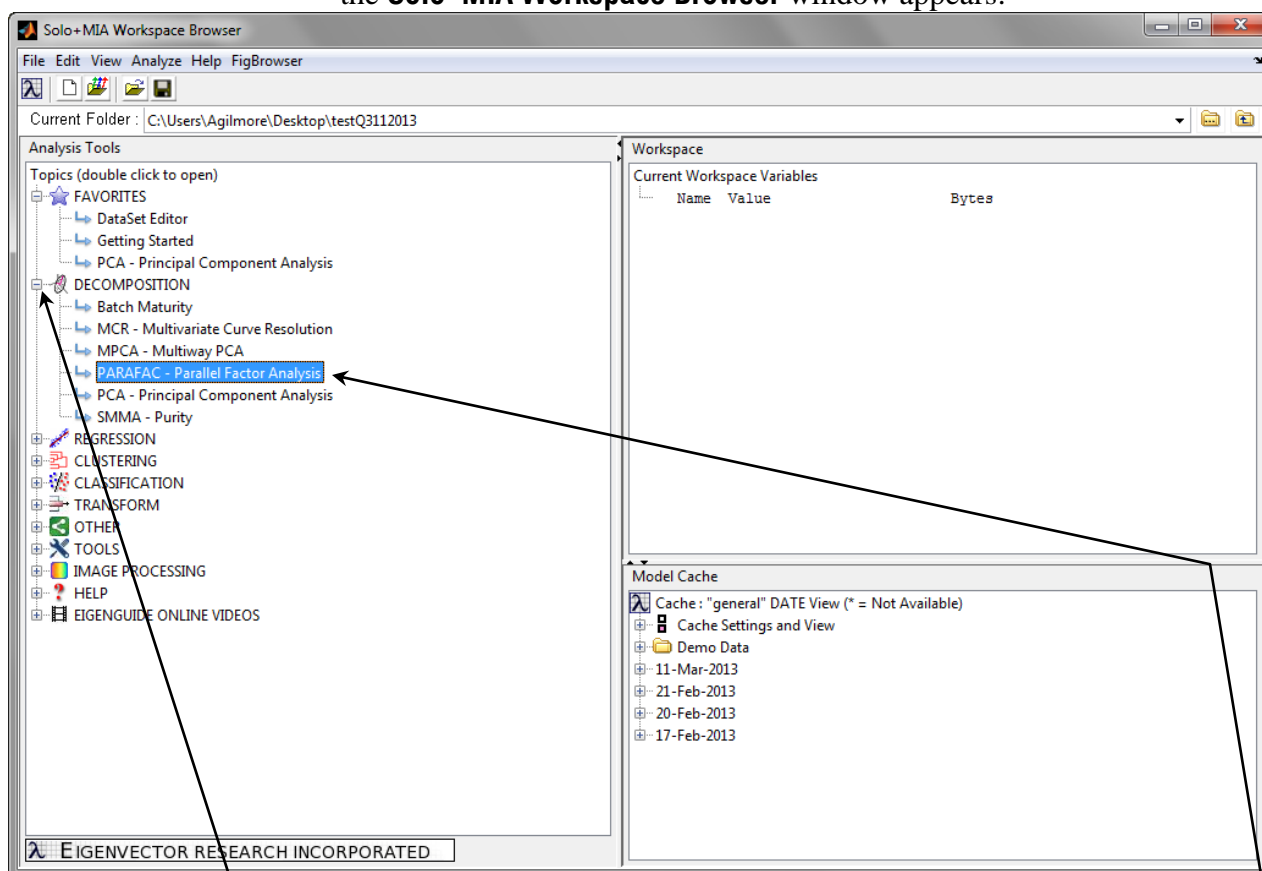

- b In the Analysis Tools area, click DECOMPOSITION to open the subheadings.
- c Click PARAFAC – Parallel Factor Analysis to begin the analysis. The **Analysis – PARAFAC (No Model)** window appears.

## 2 Choose the dataset to analyze.

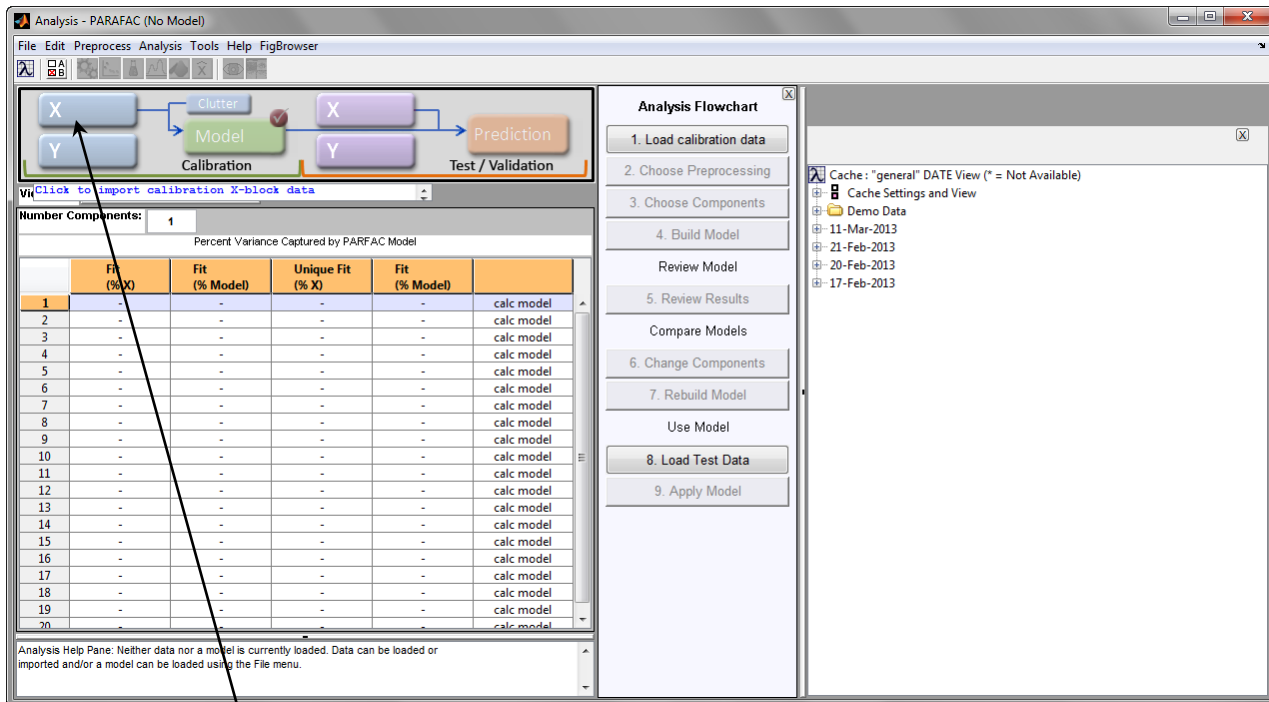

- a Click the blue-gray X button to open the desired dataset. The **Import** window opens.
- b Choose the Horiba JY Aqualog File (DAT) file type, then click the OK button.
- c The **Select File to Open** window appears.
- d Browse for and select all the files you wish to analyze, then click the Open button. Here we choose all four files. The first three are the individual components, and the fourth is a mixture of the three. All four have been fully corrected.

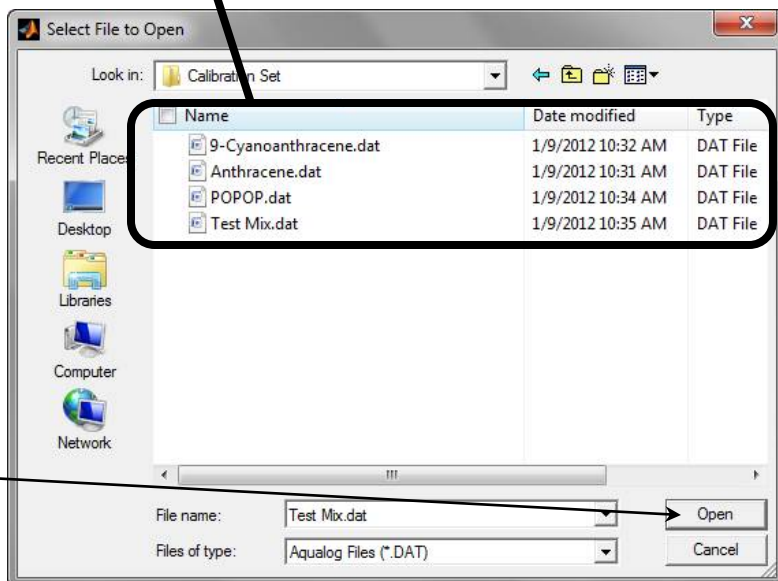
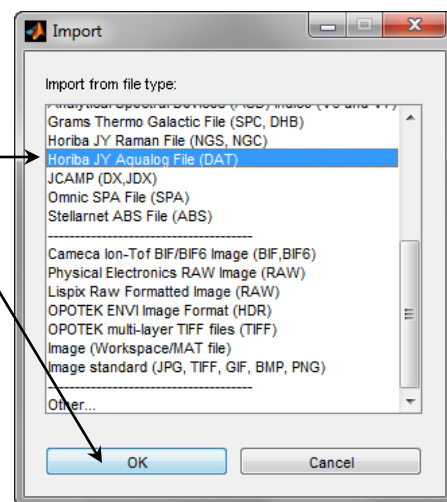

The light-blue X button turns dark blue, and the 1. Load Calibration data label is grayed-out, indicating that the data are loaded into the software.

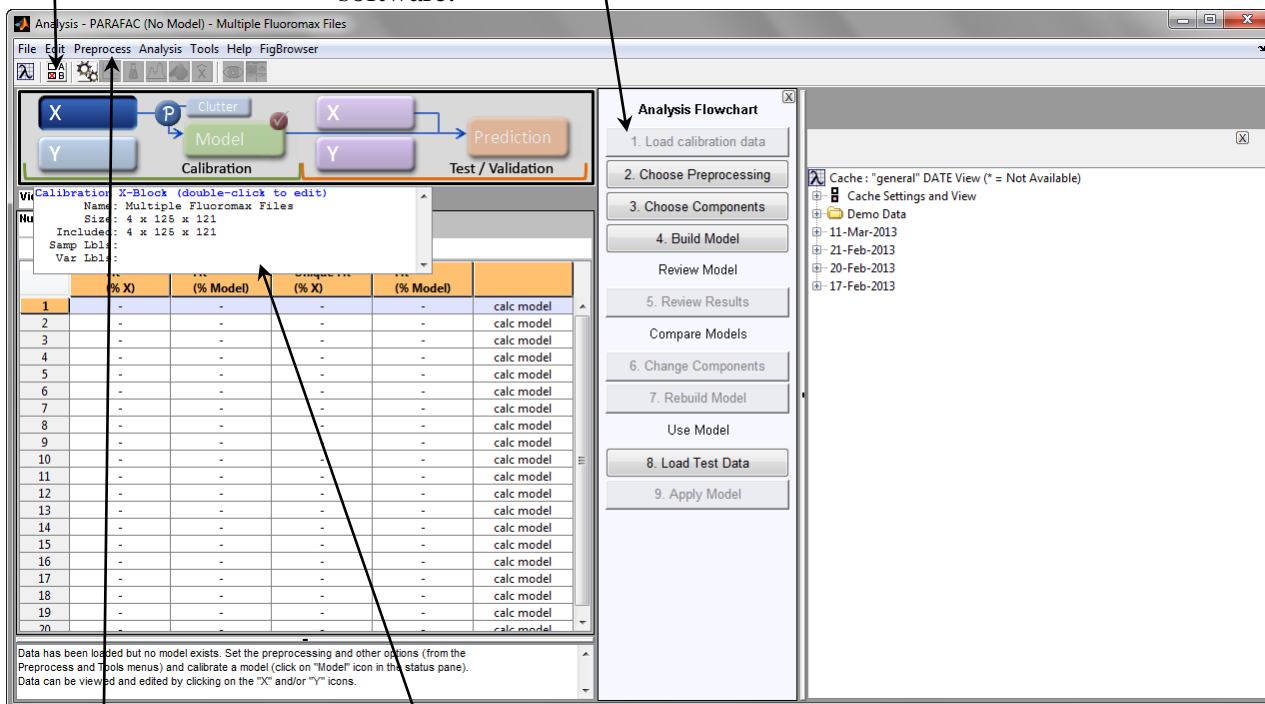

e You can double-click on the dark-blue X button to see the details about the dataset.

### 3 Edit your data, if desired.

The following algorithm edits masked areas, with an additional Raman mask, and 1<sup>st</sup>- and 2<sup>nd</sup>-order Rayleigh lines. This procedure is also useful for treating data from experiments where the solvent has not been matched for refractive index.

a Click Preprocess in the toolbar. A drop-down menu appears.

b Click X-block. A sub-menu appears.

c Choose Custom....

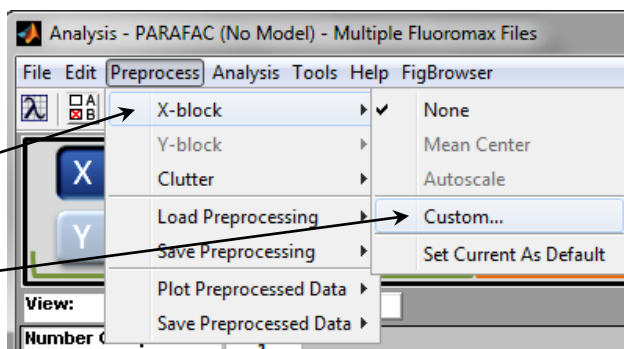

The **Preprocessing X-block** window appears:



d In the Available Methods list, choose EEM Filtering, then click the Add --> button.

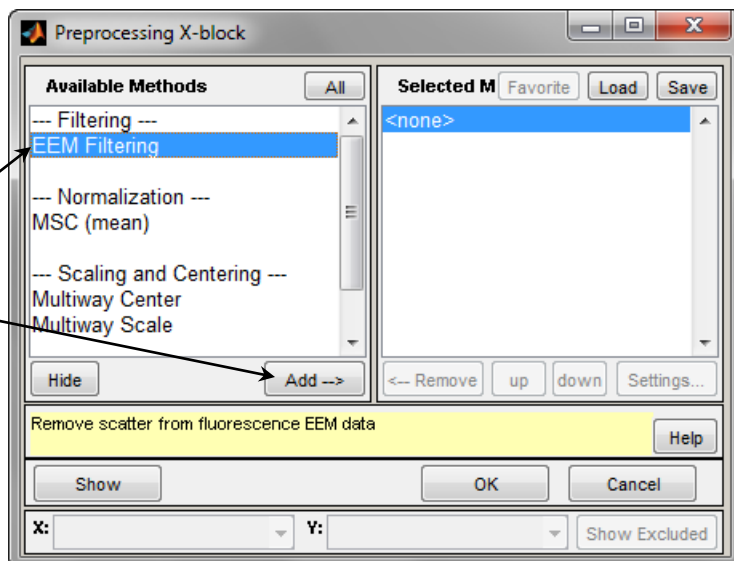

The EEM Filter Settings window appears:

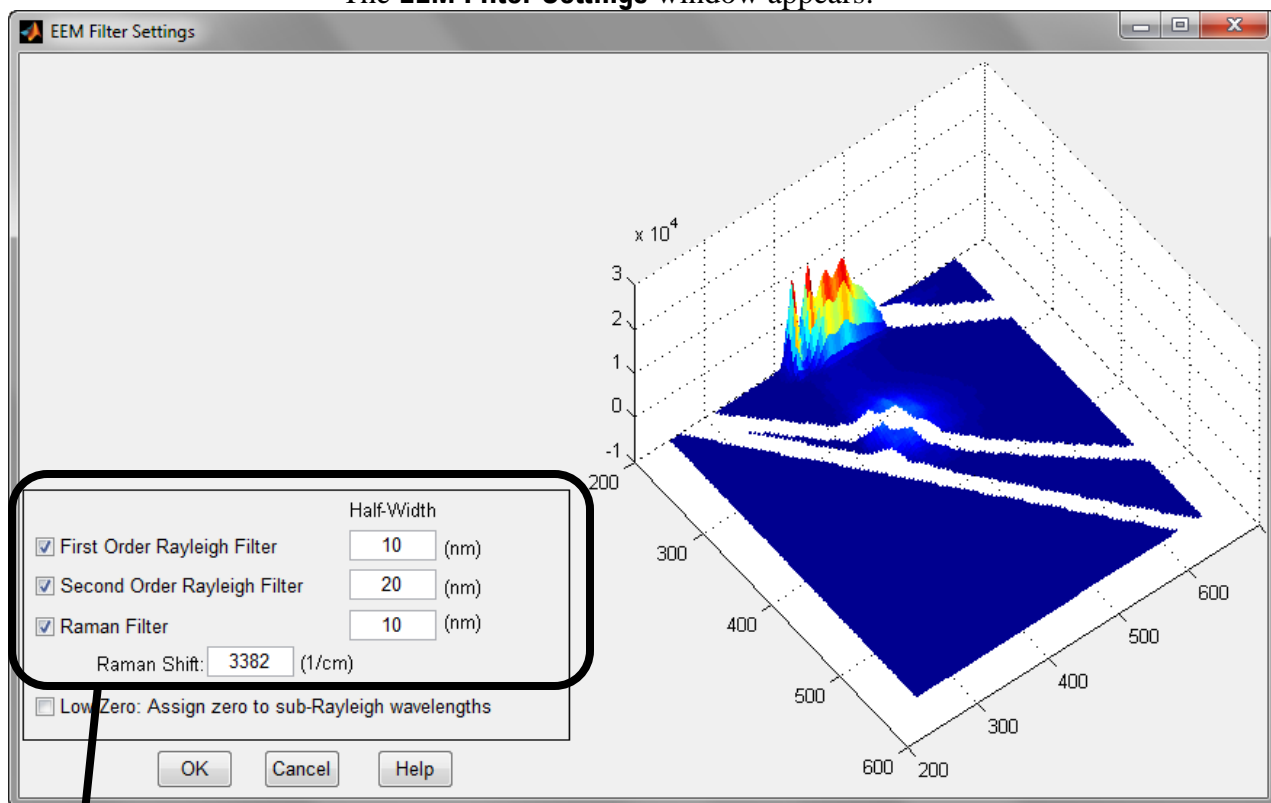

e Choose to activate:

- First Order Rayleigh Filter
- Second Order Rayleigh Filter
- Raman Filter

For each filter, enter the desired Half-Width, or leave the default. For the Raman Filter, use the default Raman Shift of 3382 cm<sup>-1</sup> or enter a different shift.

As each filter is activated, the corresponding data disappear from the plot on the right.

f Click the OK button when all desired filters are set properly.



**Note:** Activating these masking filters applies to the entire dataset you have chosen, not just the plot visible in the window.

The **EEM Filter Settings** window closes. All filters that you have activated now appear in the Selected Methods list on the right of the **Preprocessing X-block** window:

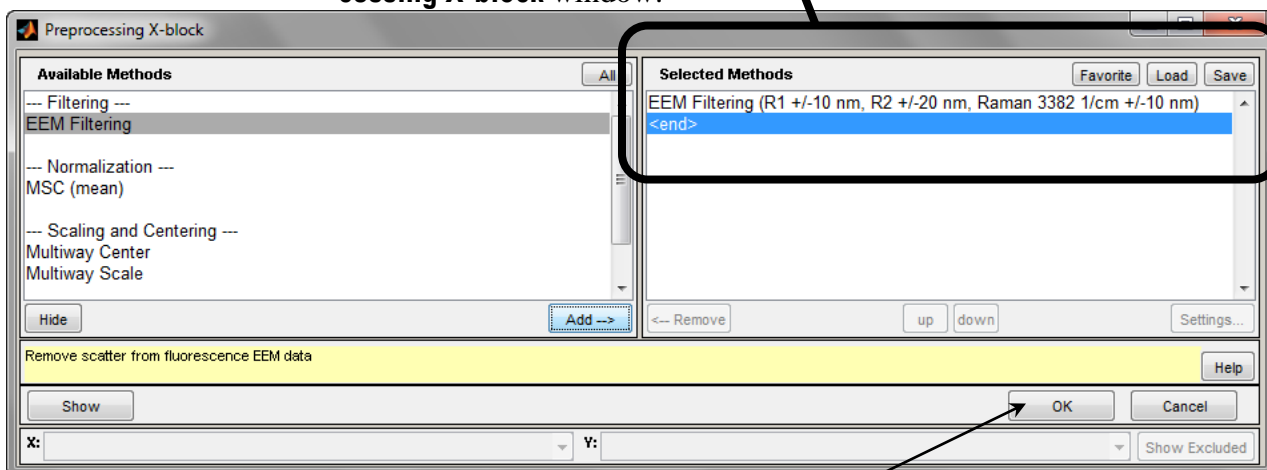

g Click the OK button to run the filters.  
The **Preprocessing X-block** window closes.

## 4 Choose the number of components.

We use 3 in this model, entered into the Number Components field.

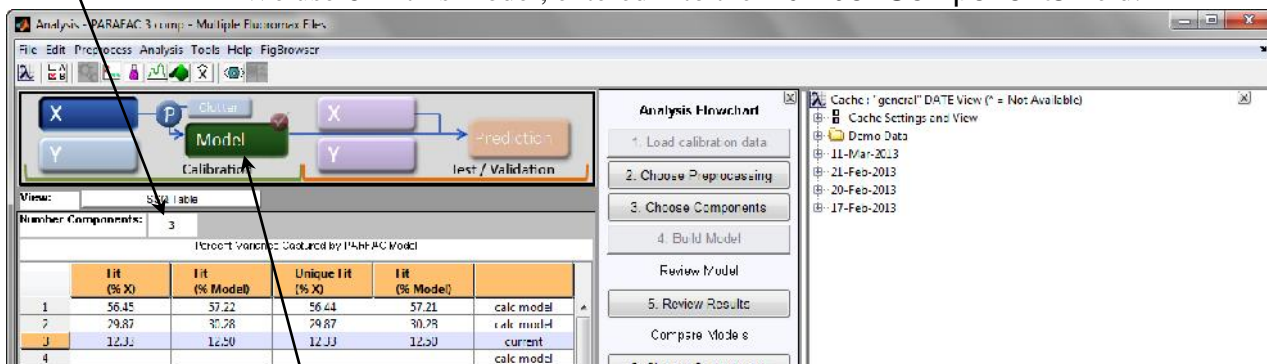

## 5 Click the green Model button.

A progress bar appears as PARAFAC fits the data. Be patient.

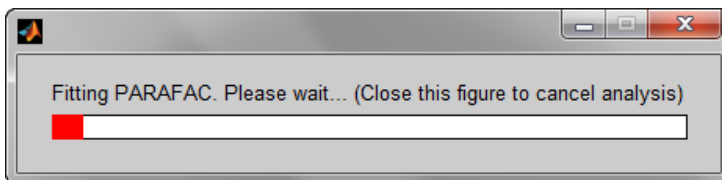

When the fitting is finished, the Model button turns dark green, and the fit appears in the table on the lower left:

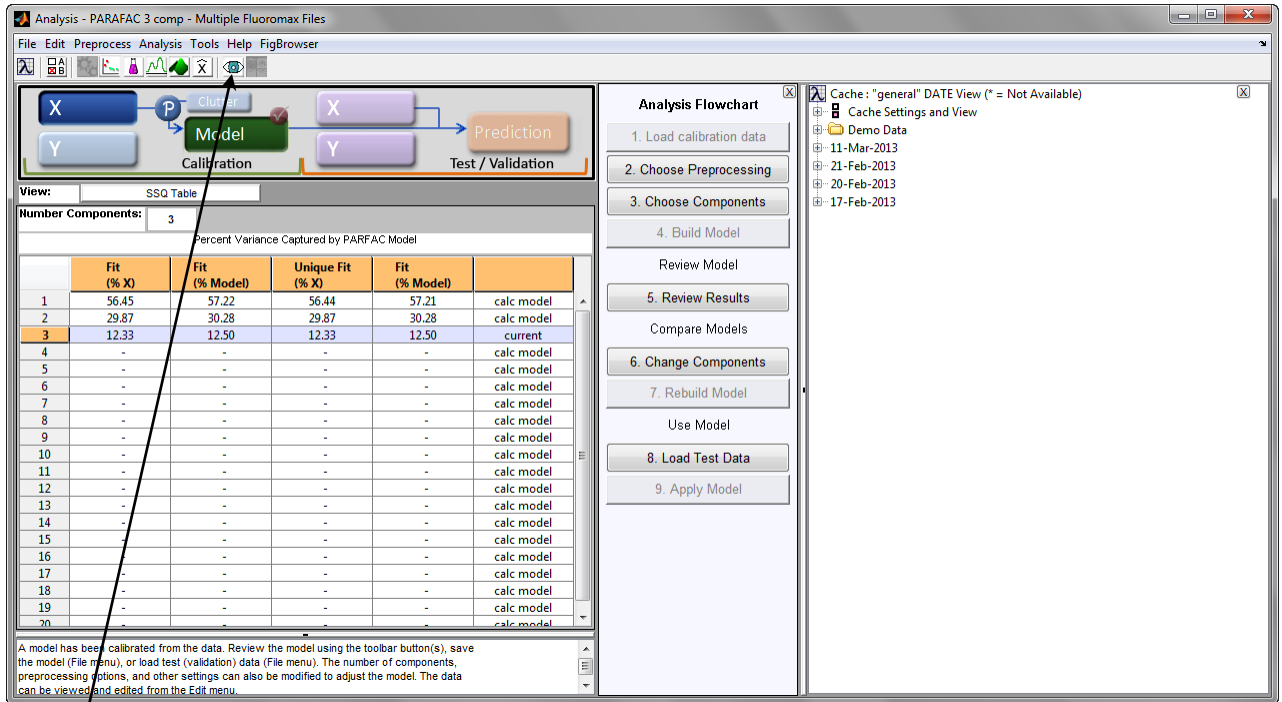

## 6 Evaluate the data.

a You can view details by clicking the View Model Details button in the toolbar.

The **Figure 1: PARAFAC** window appears with thumbnails of each graph:

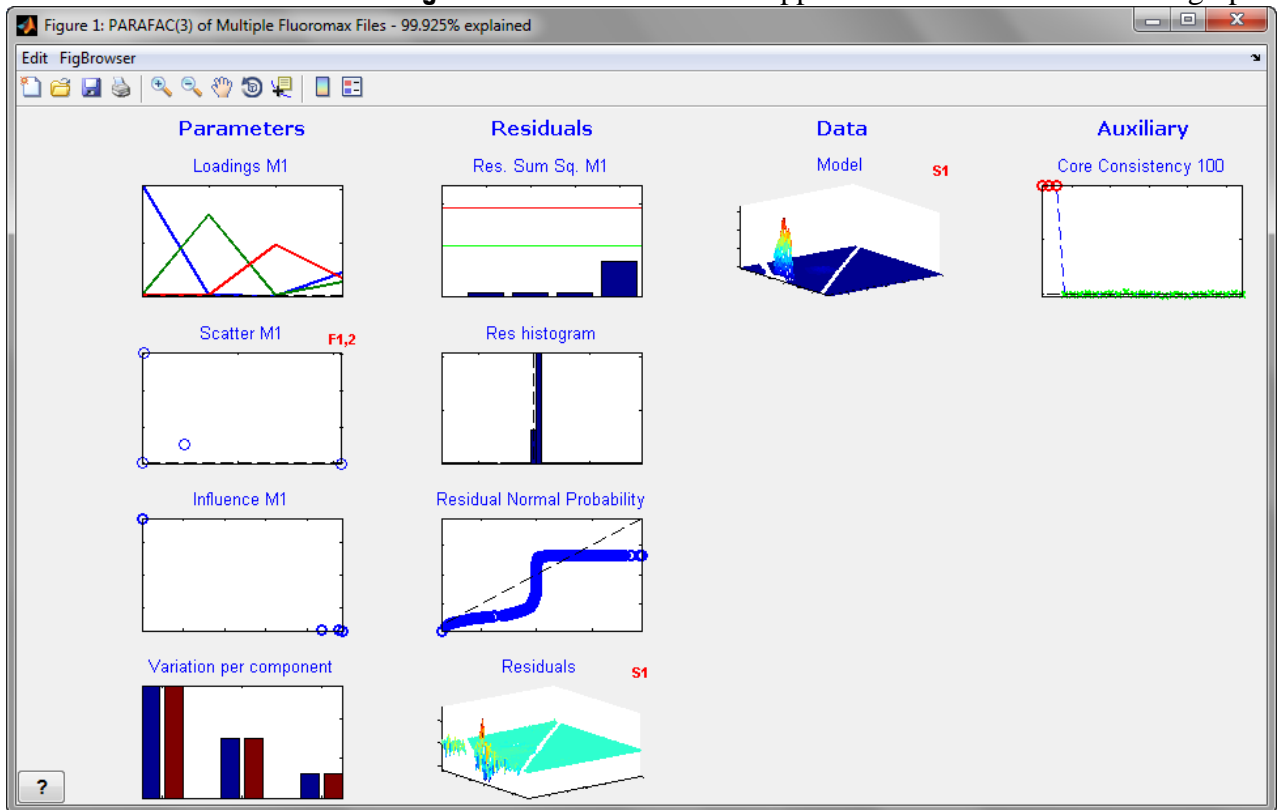

Probably the best set of parameters to view is Loadings M1 in the Parameters column, which corresponds to concentrations of each component.

**b** Left-click on the Loadings M1 thumbnail in the upper left to view successive thumbnails (M2, then M3, then M1 again) of the parameter.

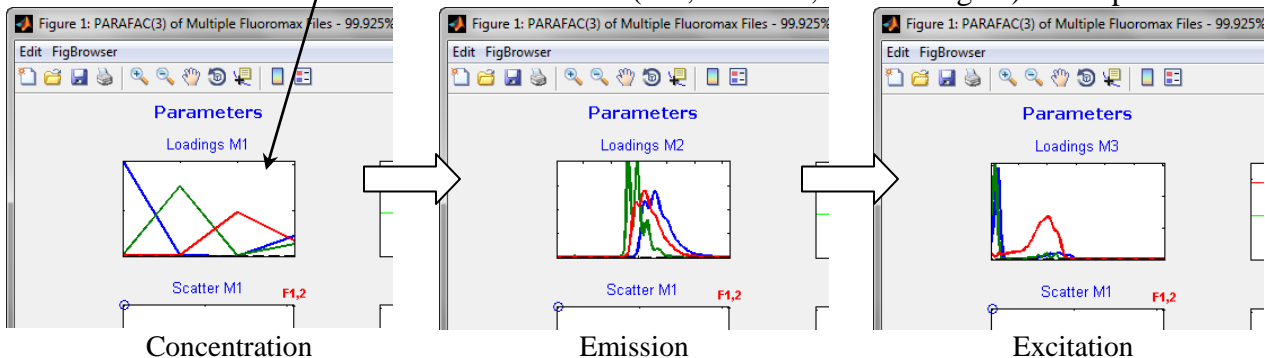

**c** Right-click on the Loadings M1 thumbnail to view an enlarged version of the graph in a separate window. When you right-click, a This plot in separate window message appears:

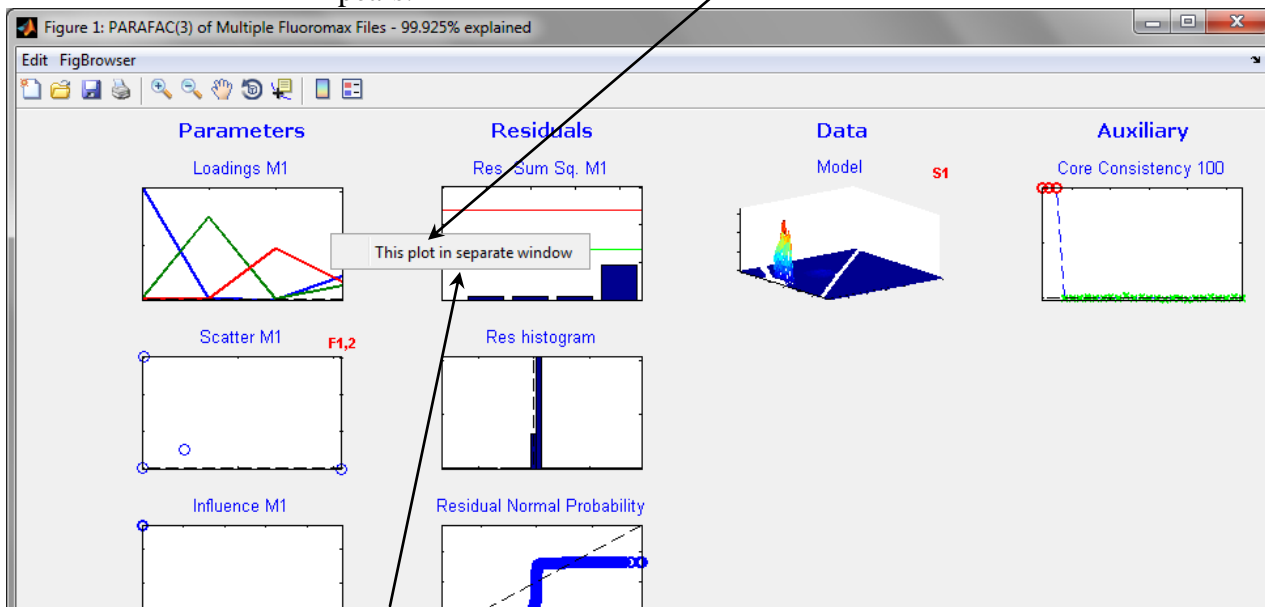

Click on the message to open the visible plot in a separate window:

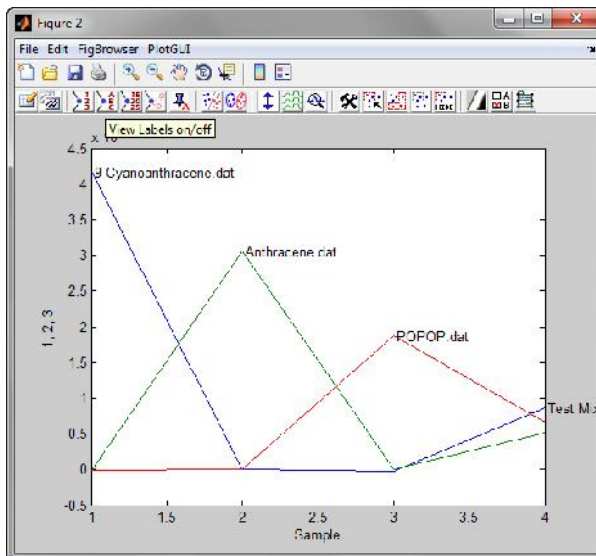

d Turn the labels on and off by clicking the View Labels on/off button

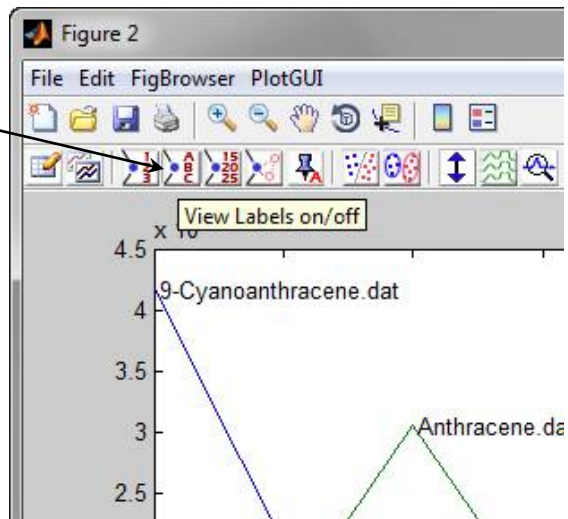

e Review the data and models themselves by left-clicking the red S# next to the Raw data thumbnail in the Data column to see successive sample EEMs:

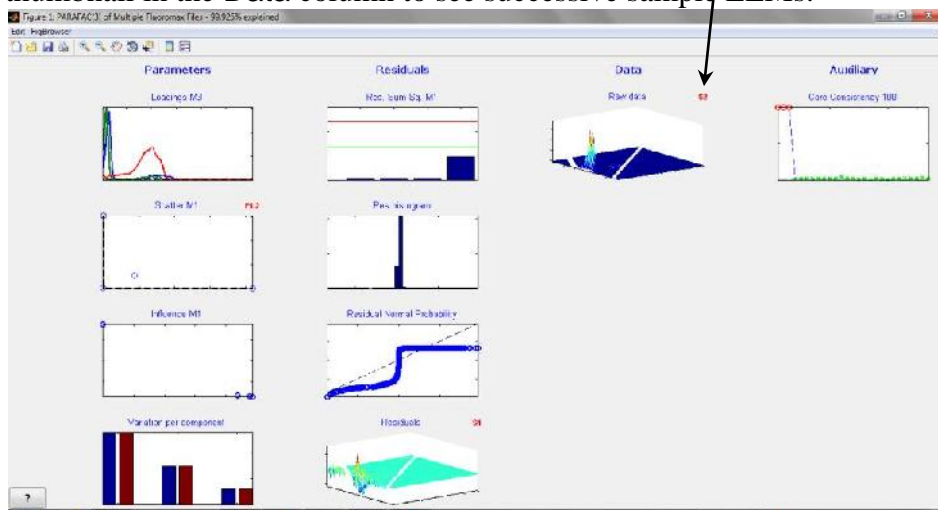

then

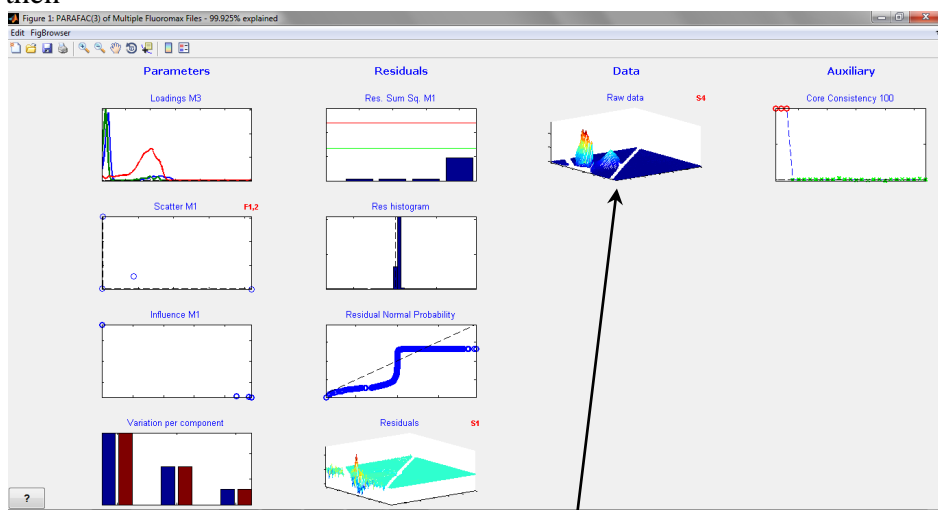

f Left-click on the thumbnail plot itself to switch between the raw data and the model.

# 7 Evaluate the model.

a Look at the goodness-of-fit value at the top of the window:

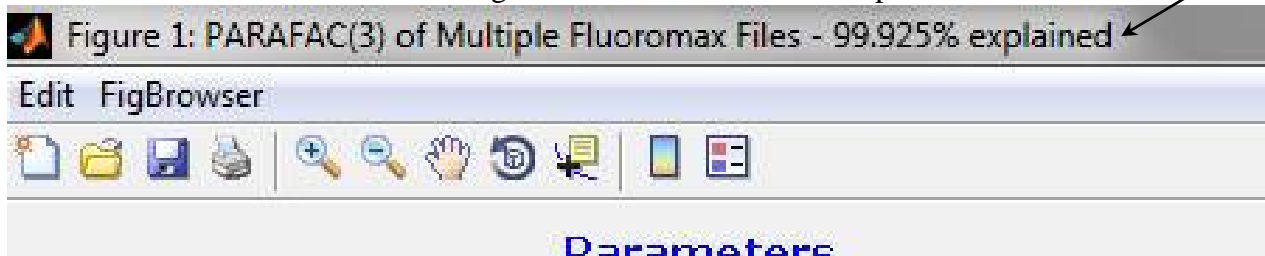

b Examine the Residuals column, especially the Res. Sum. Sq. M1 thumbnail.

Confidence intervals are the green (95%) and red lines (99%):

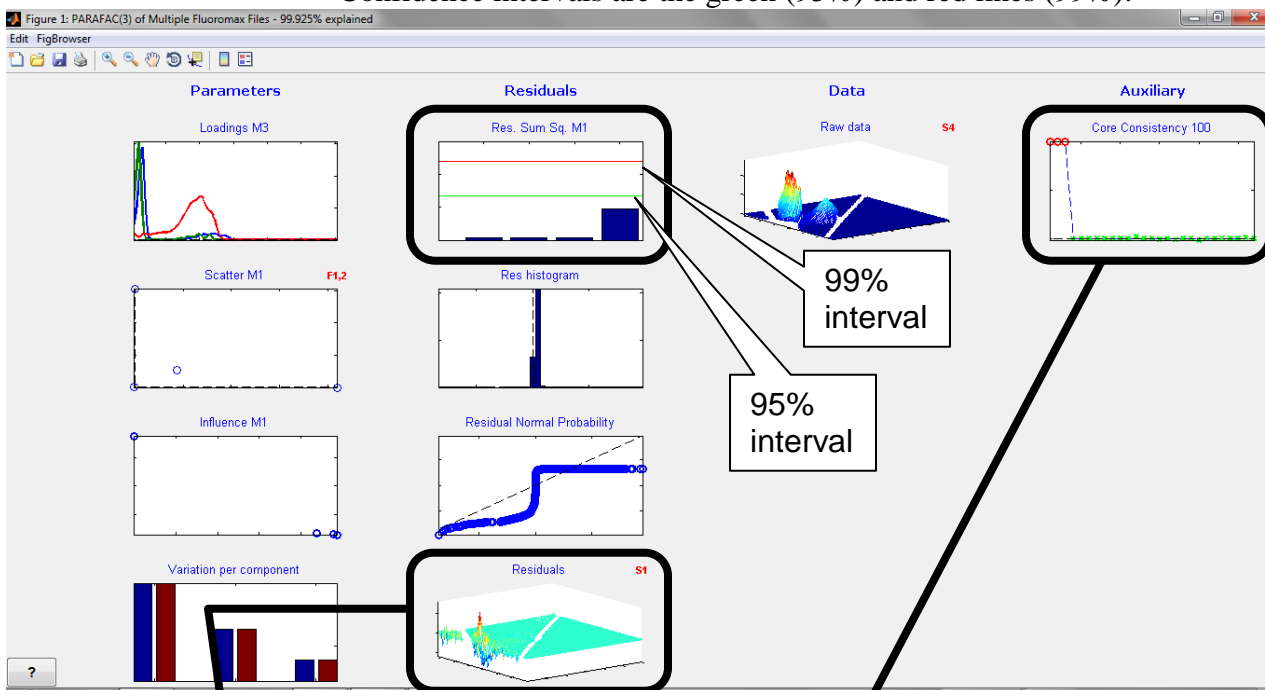

c Examine the Core Consistency thumbnail in the Auxiliary column. Three components together make up 100% of the mixture, with no unexplained leftovers, so it is a good fit.

d Examine the Residuals thumbnails in the Residuals column. These are plots of the data minus the model, which should appear random for a good fit.

- e To see the individual components in the sample, in the **Analysis** window click the Plot 2D Loading Surfaces button .

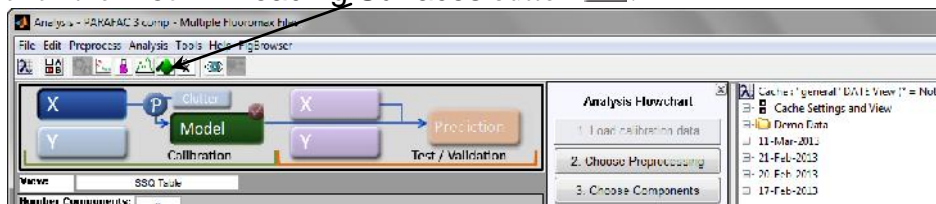

Two windows appear simultaneously:

- **Plot Controls** window
- **Loading Surfaces** window

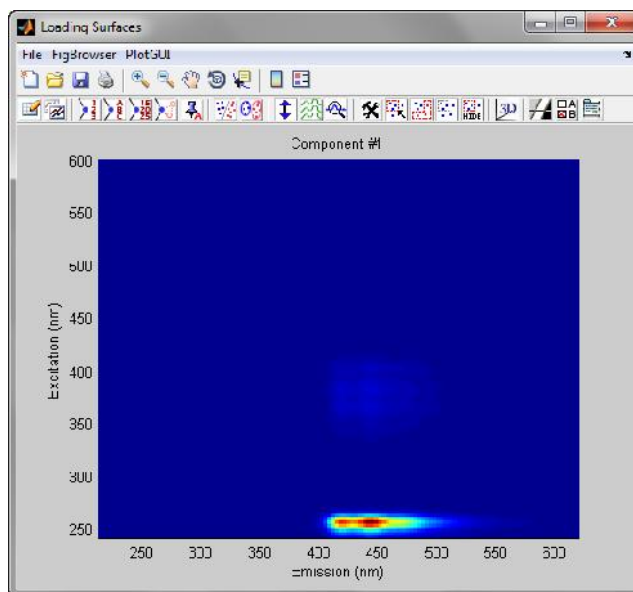
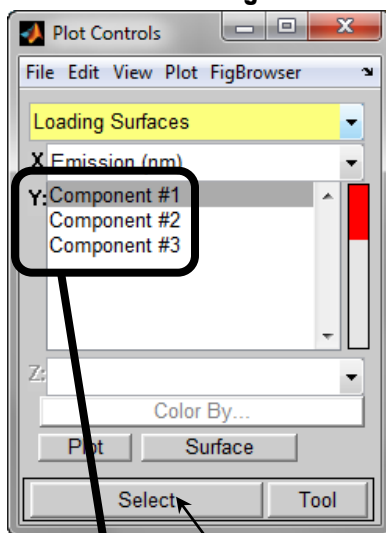

In the **Plot Controls** window, highlight which component you want to view in the **Loading Surfaces** window, then click the **Select** button.



**Note:** The plots produced in the **Loading Surfaces** window are good for publication purposes.

## 8 Examine the residuals.

- a In the **Analysis** window, click the Plot Data Estimate and Residuals button .

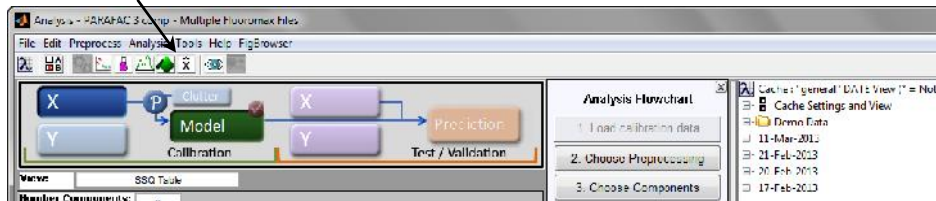

The **Display Data** window appears:



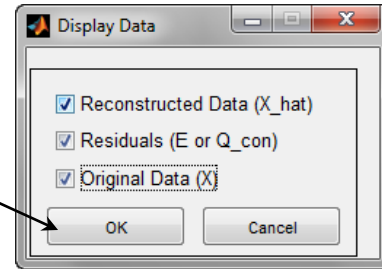

b Choose the data you wish to display, then click the OK button.

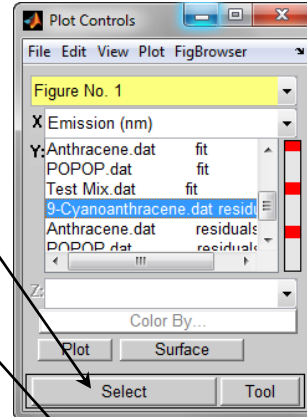

The **Plot Controls** window asks which data sets to display:

c Choose the set(s) and click the **Select** button.  
The plot appears.



d For ease of viewing, click the **Edit All Settings** button .

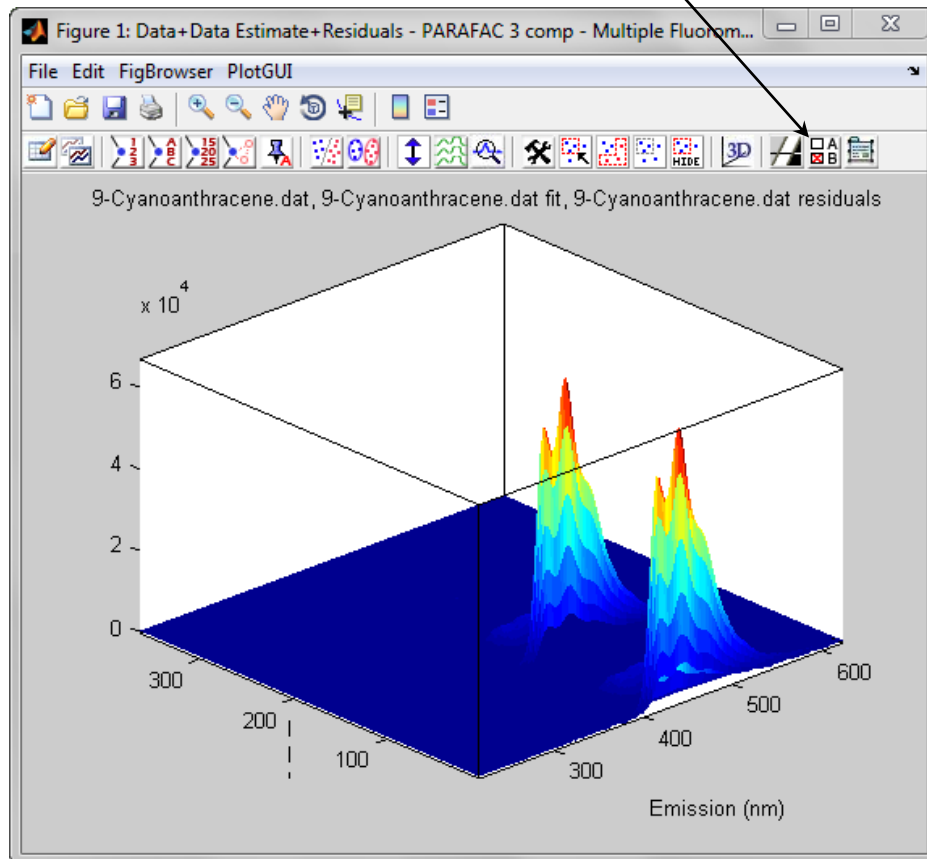

The **Options/Preferences** window appears:



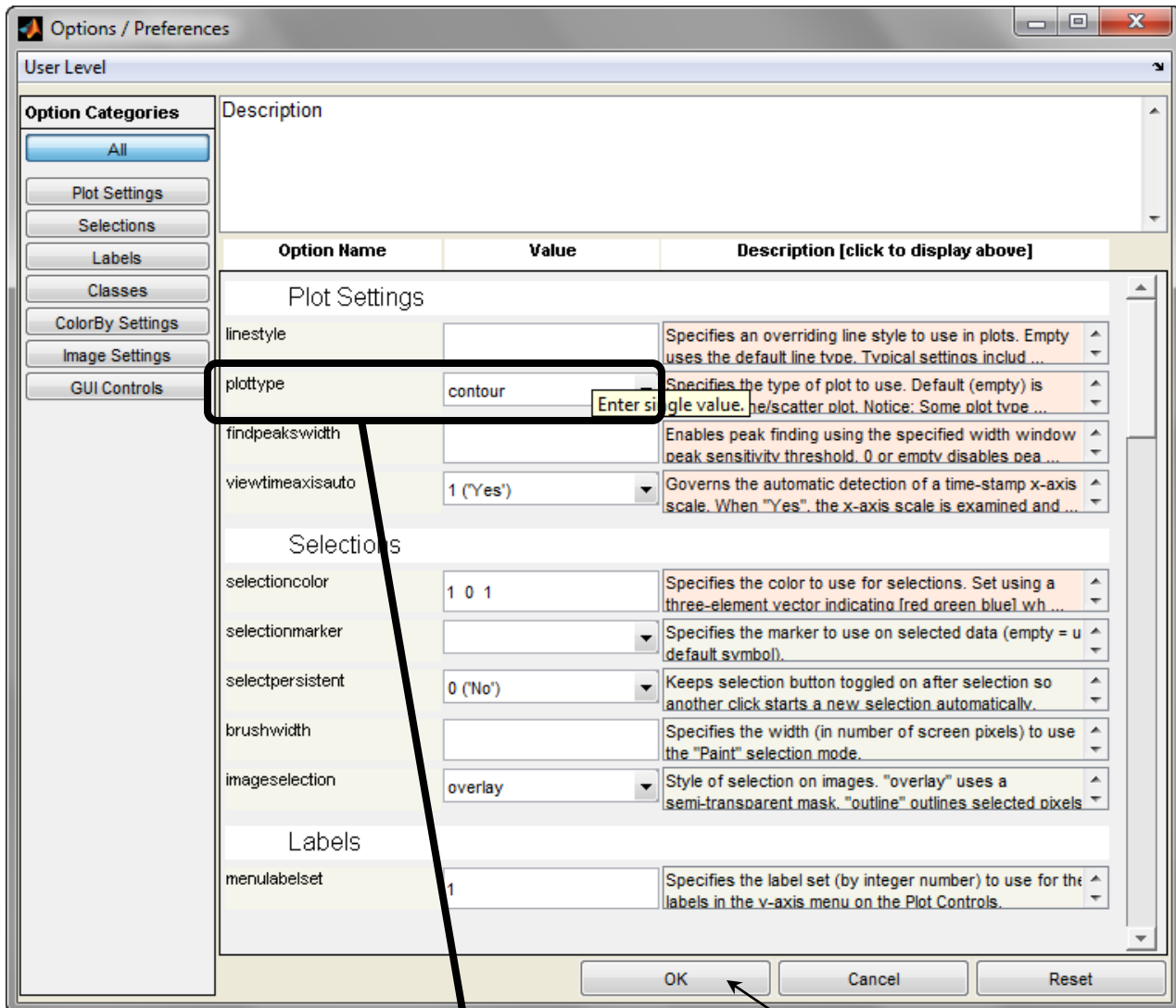

e Change the plottype to contour, then click the OK button. The plot changes to a "top view":

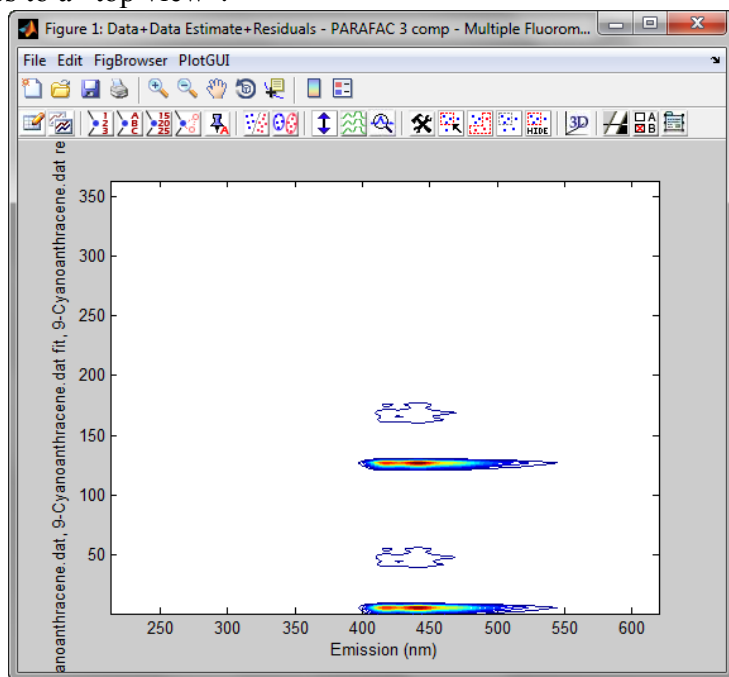

# 9 Change the fitting parameters if you wish.

a In the **Analysis** window, choose Edit.  
A drop-down menu appears.

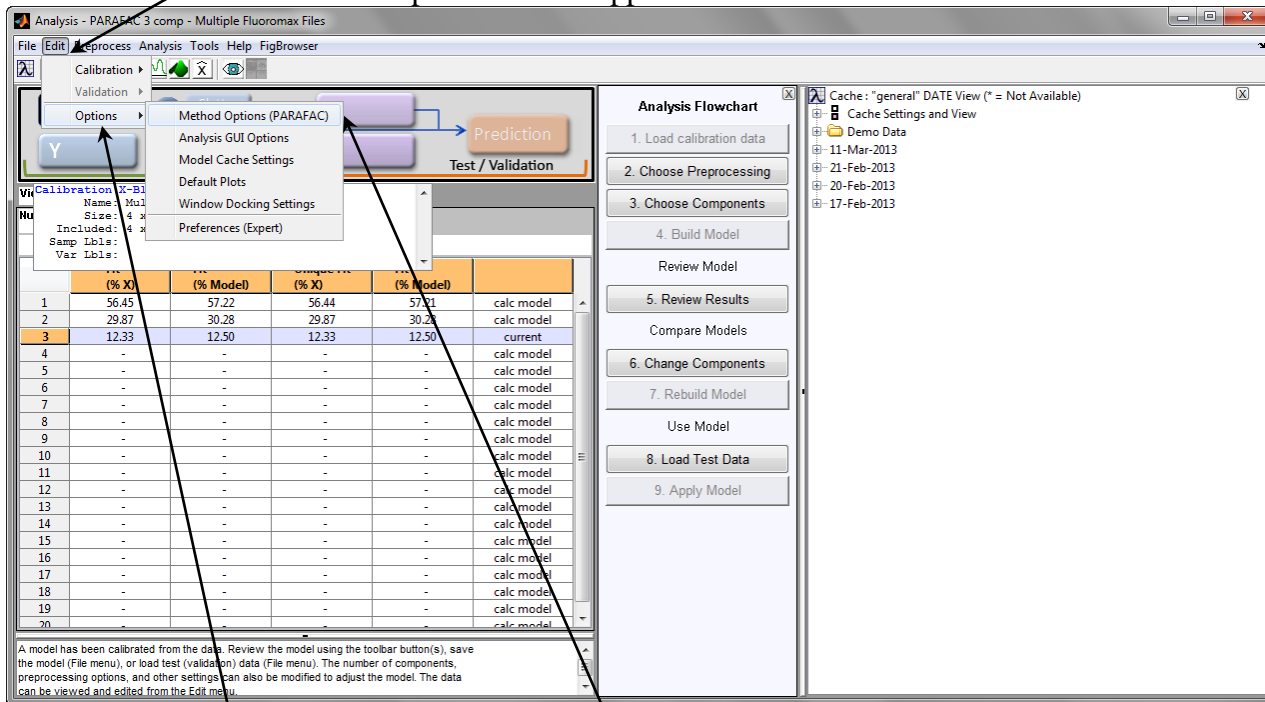

b Choose Options.  
A sub-menu appears.

c Choose Method Options.  
The **Options/Preferences** window appears:

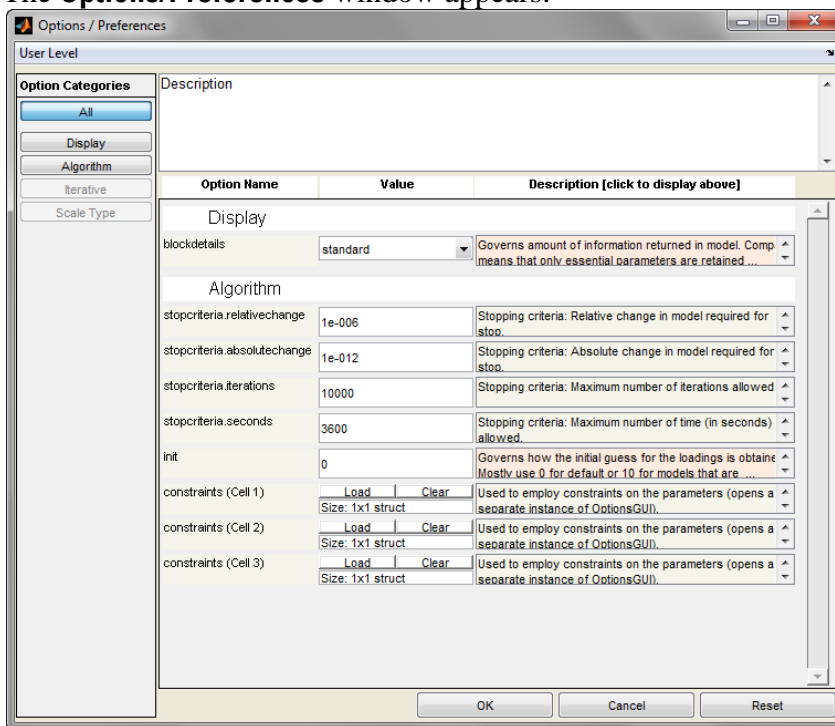

Among the important parameters to change is constraints. Here we want three constraints per loading, and none negative.

d Click Load, and the Constraints area appears. From the Value drop-down menu, choose nonnegativity, then click the OK button.

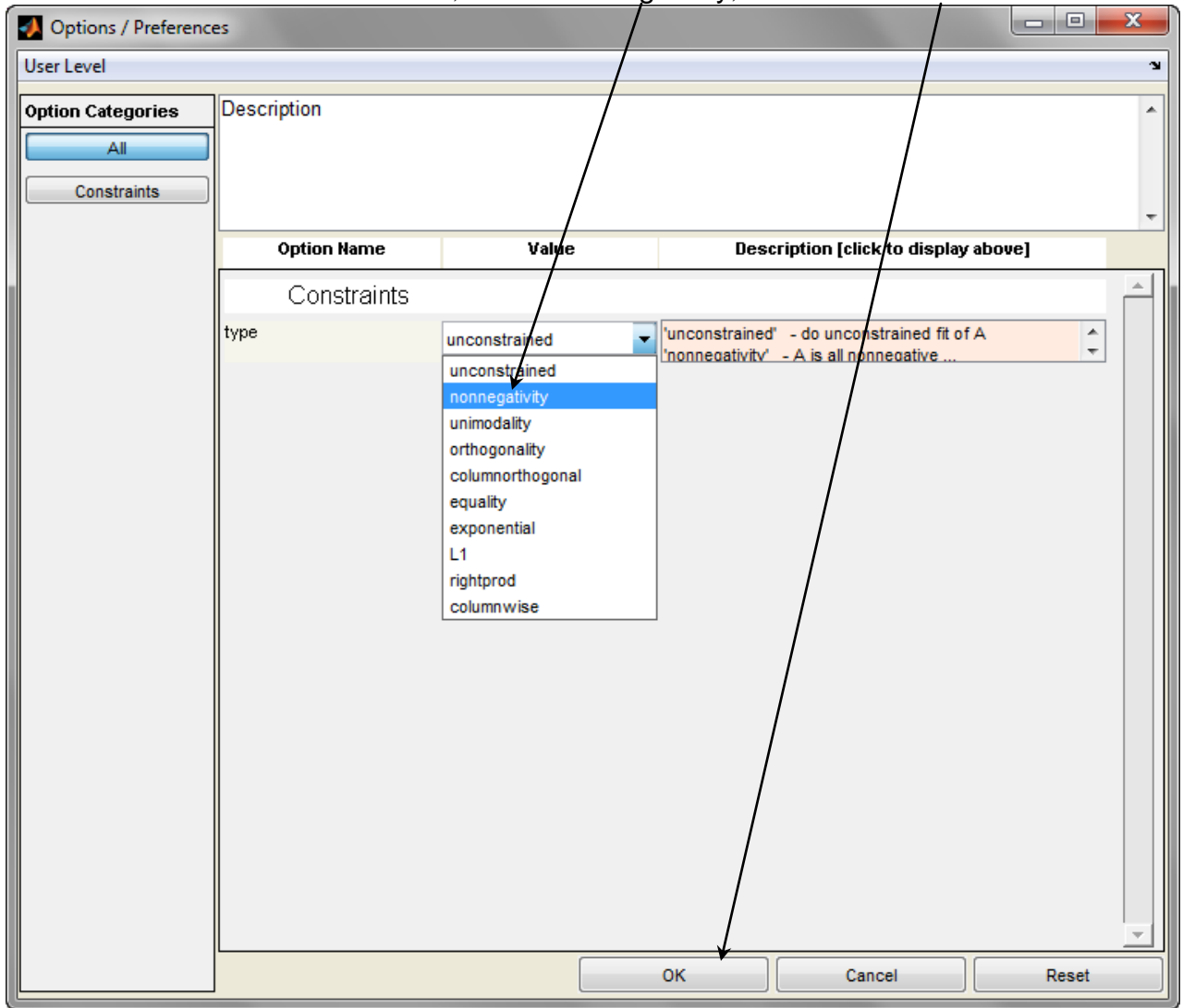

e Repeat the other two loadings so that all loadings cannot be negative.

# Perform Split-Half Analysis button

This function may be used if there are more than four samples in a dataset. **Perform Split-Half Analysis** splits the dataset into two halves, and compares each half-set to the other half-set, and each half-set to the whole dataset. This is a check for consistency within the data.

- 1 Load into the PARAFAC window a dataset for analysis.

The dataset must contain more than four data points.

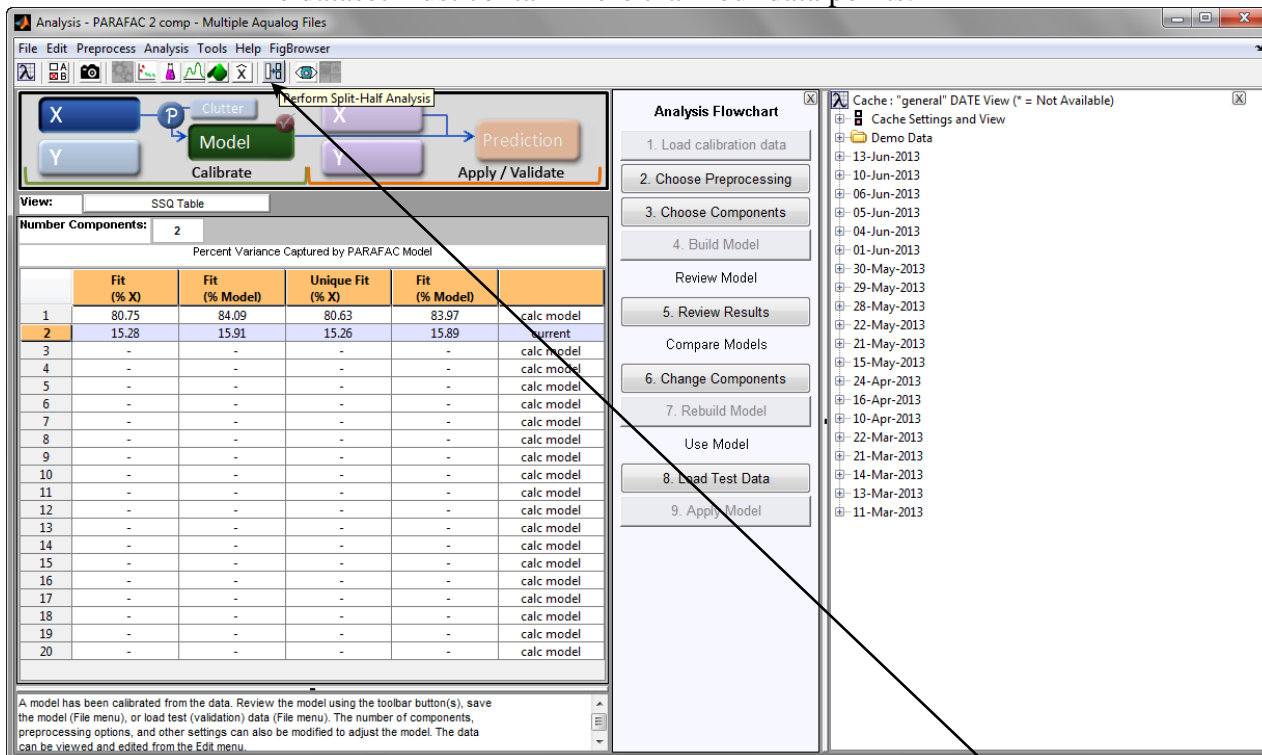

- 2 In the PARAFAC window, click the **Perform Split-Half Analysis** button .

The software performs a split-half analysis. Two progress bars appear: The **Performing Split Half Analysis** progress bar, and the **Fitting PARAFAC** progress bar.

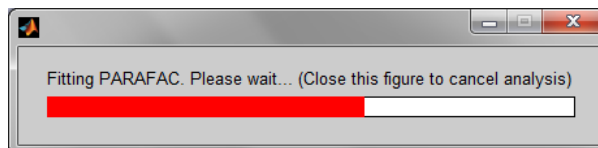
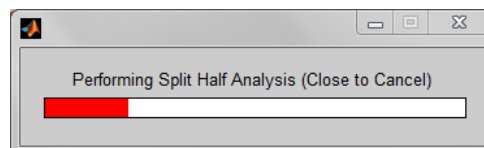

When the analysis is complete, a series of graphs appear on the **Split Half Analysis Results** window:

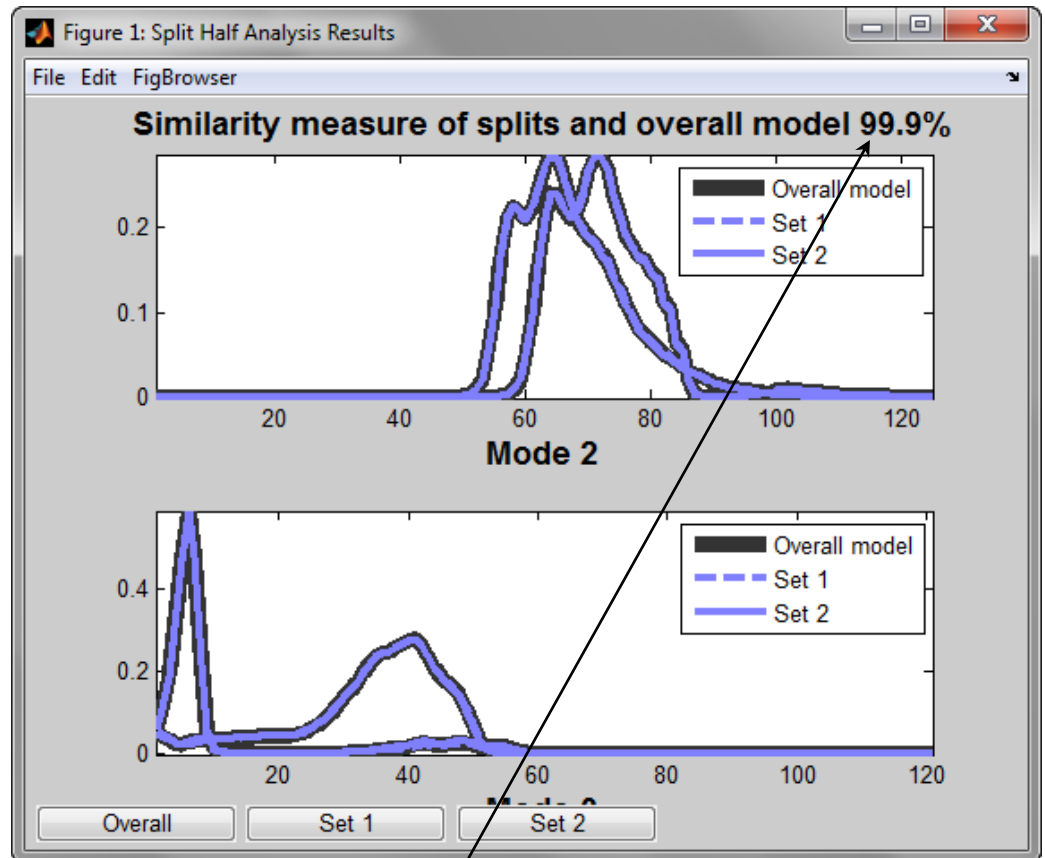

The similarity measure is the check on how well each dataset matches to the other. Here, the similarity is 99.9%, which is excellent.

# Using Principal-Component Analysis

This can help corroborate a fit you have done with PARAFAC, either before or complementary to the PARAFAC modeling.

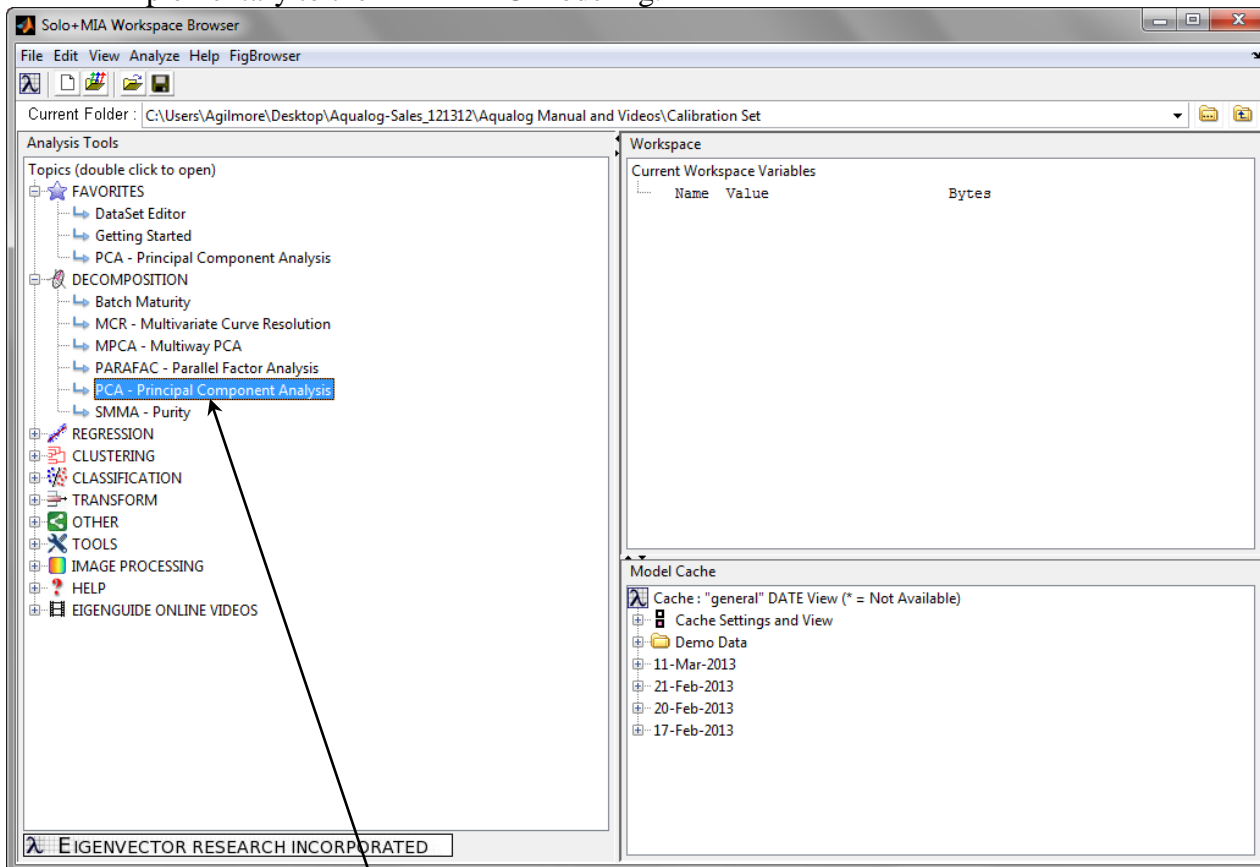

- 1 In the **Solo+MIA Workspace Browser** window, open the **DECOMPOSITION** header, and click **PCA – Principal Component Analysis**.

The **Analysis – PCA (No Model)** window appears:

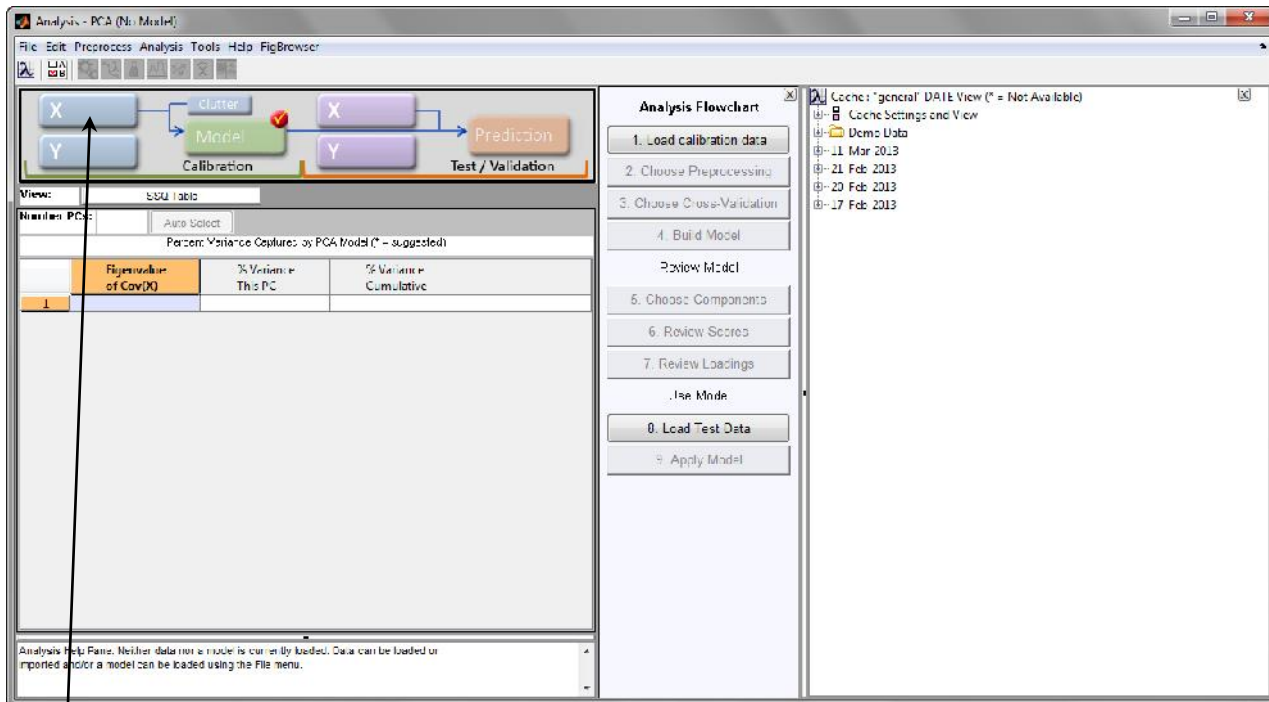

## 2 Convert the 3-D arrays that .DAT files use into 2-D arrays.

This is often termed “unfolding”.

a Click the light-blue X button to import the data file(s). The **Import** window appears.

b Choose the Horiba JY Aqualog File (DAT) type, and click the OK button. The **Select File to Open** window appears.

c Choose the desired files, then click the Open button. Here we choose the three individual components, plus the mixture.

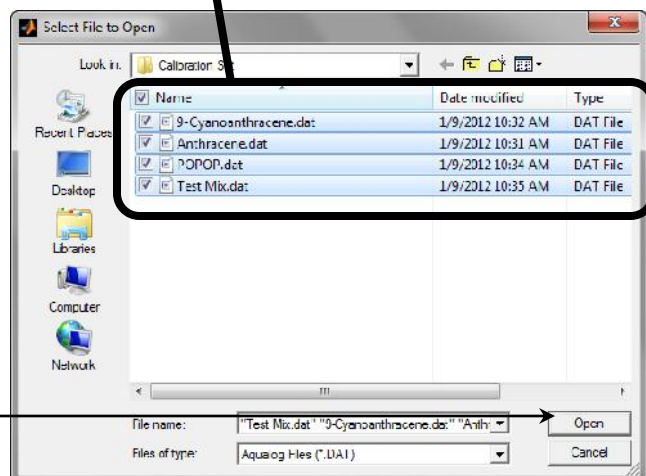
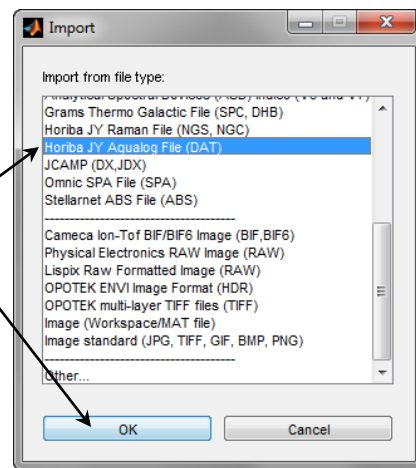

The data load into Solo, and the light-blue X button turns dark blue.

- d In the **Analysis** window, right-click the dark-blue X button. A menu opens.

- e Choose **Edit Data**. The **Multiple Fluoromax Files – DataSet Editor** window appears:

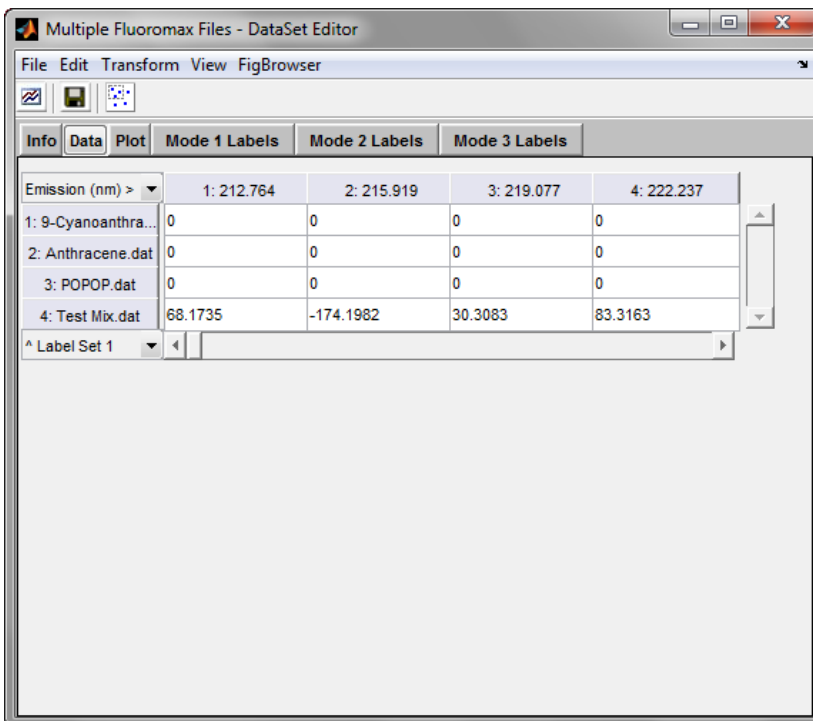
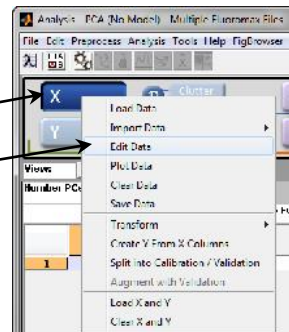

- f Click **Transform**. A menu appears.

- g Choose **Reshape**. The **Reshape Data** window opens:

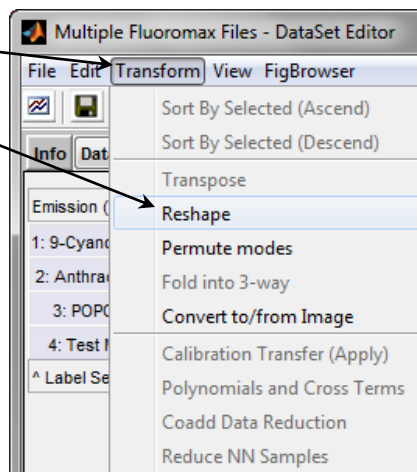
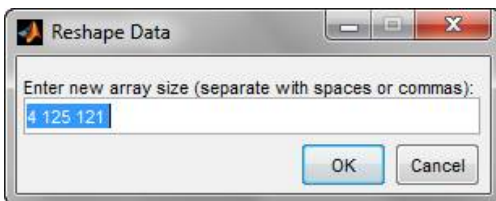

We want to reshape this particular data file so that it becomes 4 matrices × 125 excitations × 121 emissions.



h Enter an asterisk between the 125 and 121, as shown below:

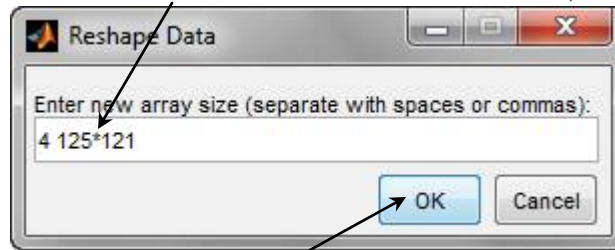

i Click the OK button.  
The **Warning: Replacing Missing Data** window appears:



j Click the OK button.

The data are reshaped and appear in the **Analysis** window:

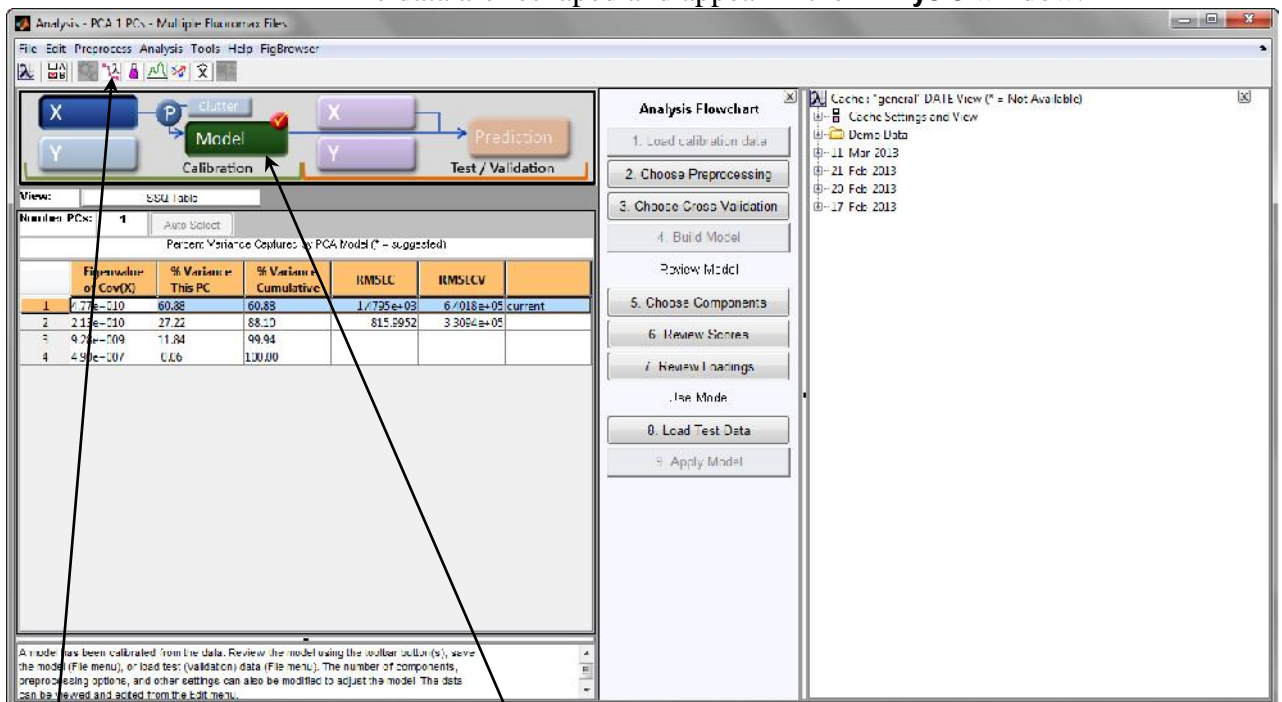

3 Model the data by clicking the Model button.

The model executes.

4 Evaluate the model.

a Click the Plot Eigenvalues/Cross-validation Results button .

- b The **Plot Controls** window opens.  
 Choose **Cumulative Variance Capture**,  
 and click the **Plot** button.

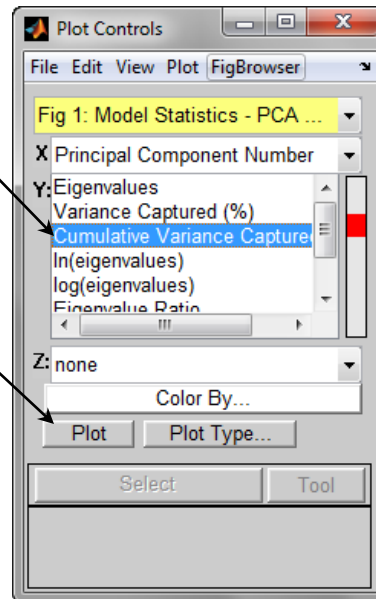

The plot opens.

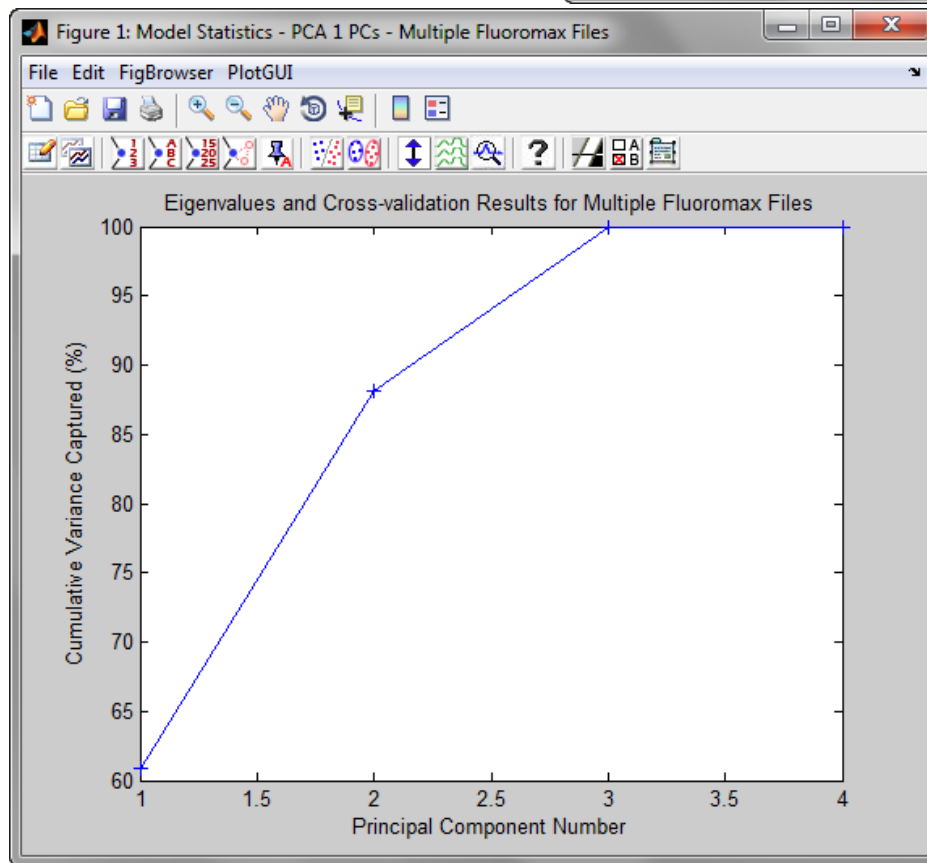

In this plot, note that component 1 constitutes 60% of the mixture, components 1 + 2 are 88%, and components 1 + 2 + 3 = 100% of the mixture, with no unexplained variance. Thus this is a good fit.

# Using classical least-squares fitting

This can be useful for calibrating EEMs using pure standards as components from a library.

## 1 Import the standards.

a In the **Solo+MIA Workspace Browser** window, in the Analysis Tools area, open the REGRESSION header, and click the CLS – Classical Least Squares sub-header.

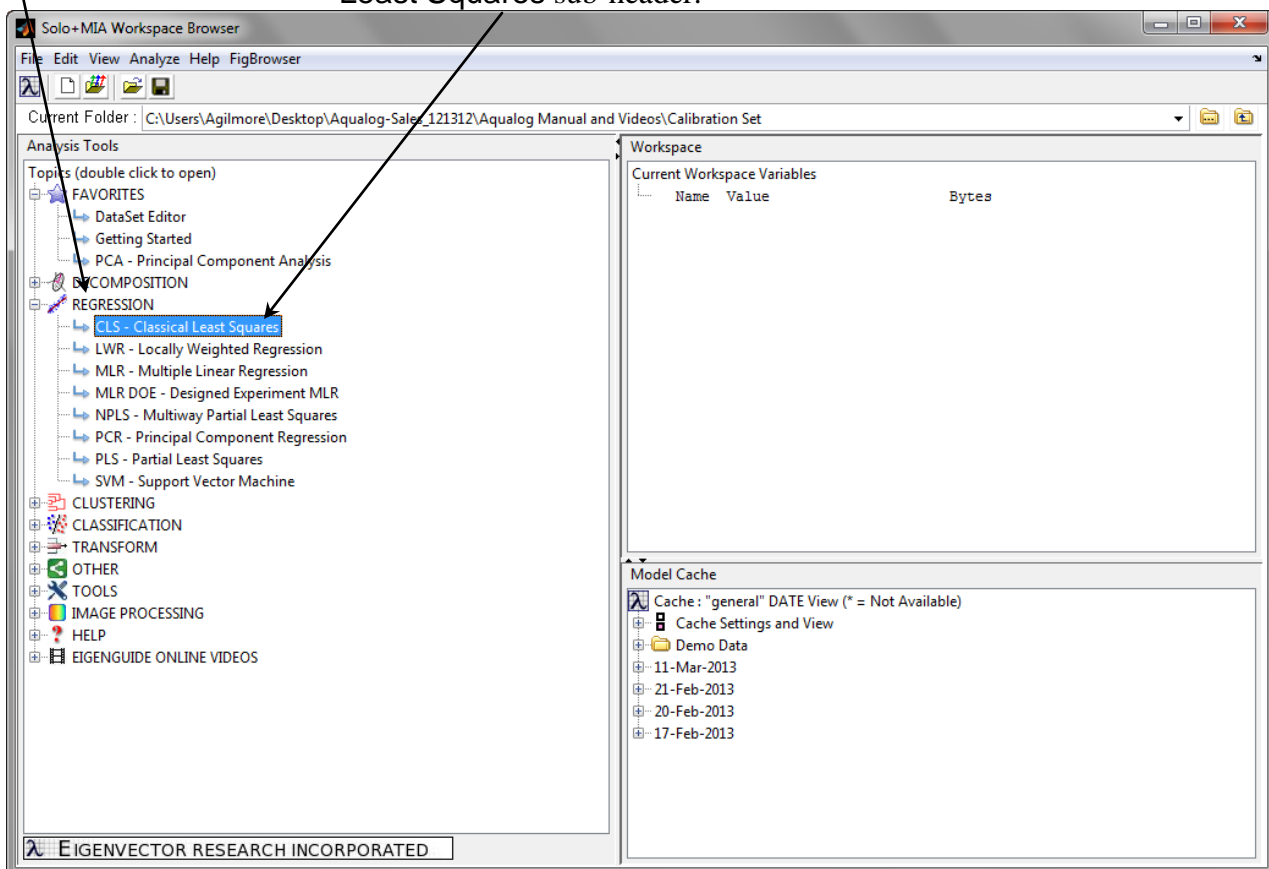

The **Analysis – CLS (No Model)** window appears:

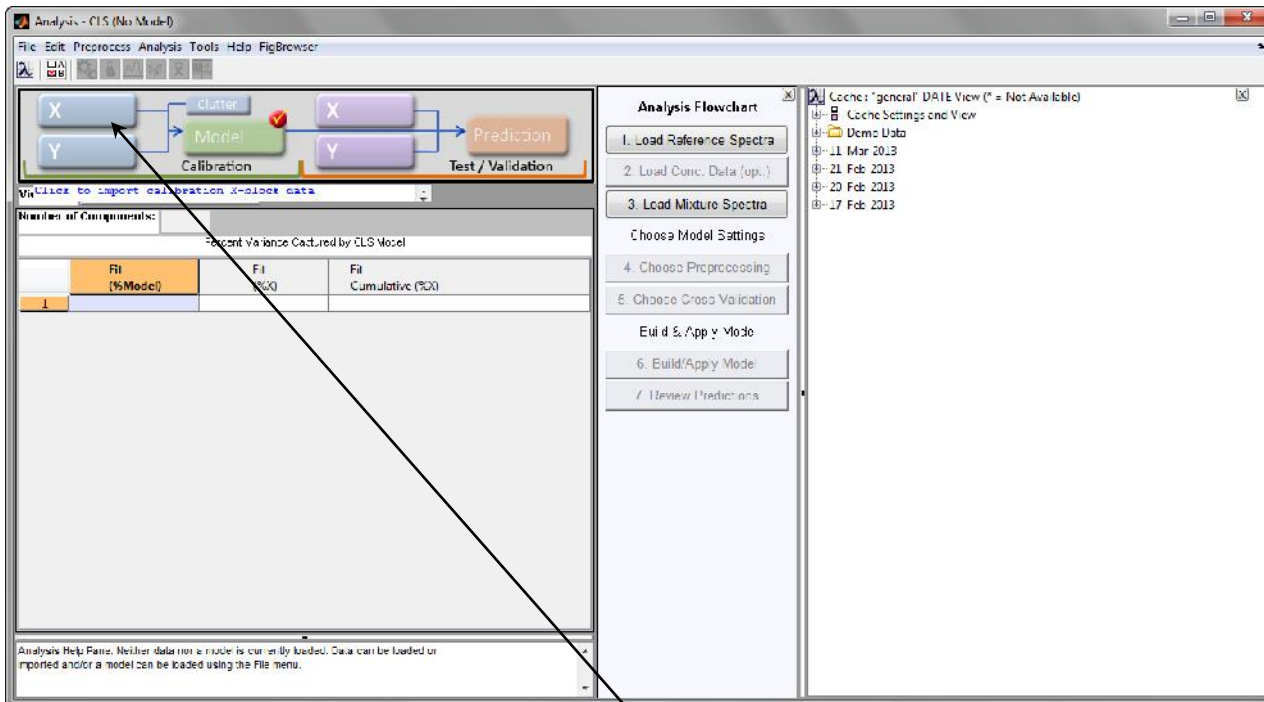

b Click the light-blue X button. The **Import** window appears.

c Choose **Horiba JY Aqualog File (DAT)**, and click the **OK** button.

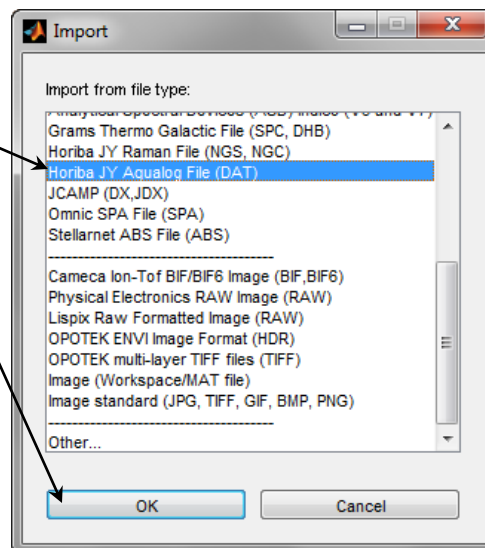

The **Select File to Open** window appears:

d Browse for and choose the three pure

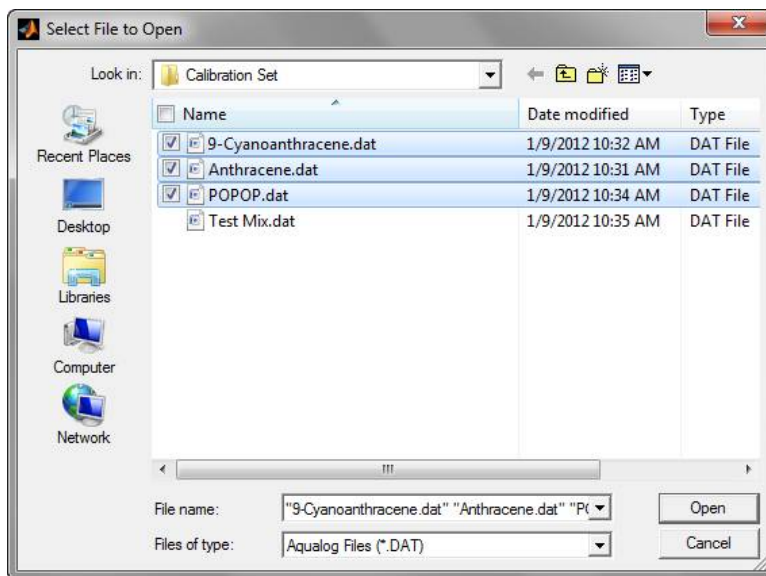

components as standards, and click the Open button.

The light-blue X button turns dark blue to show that the data are imported.

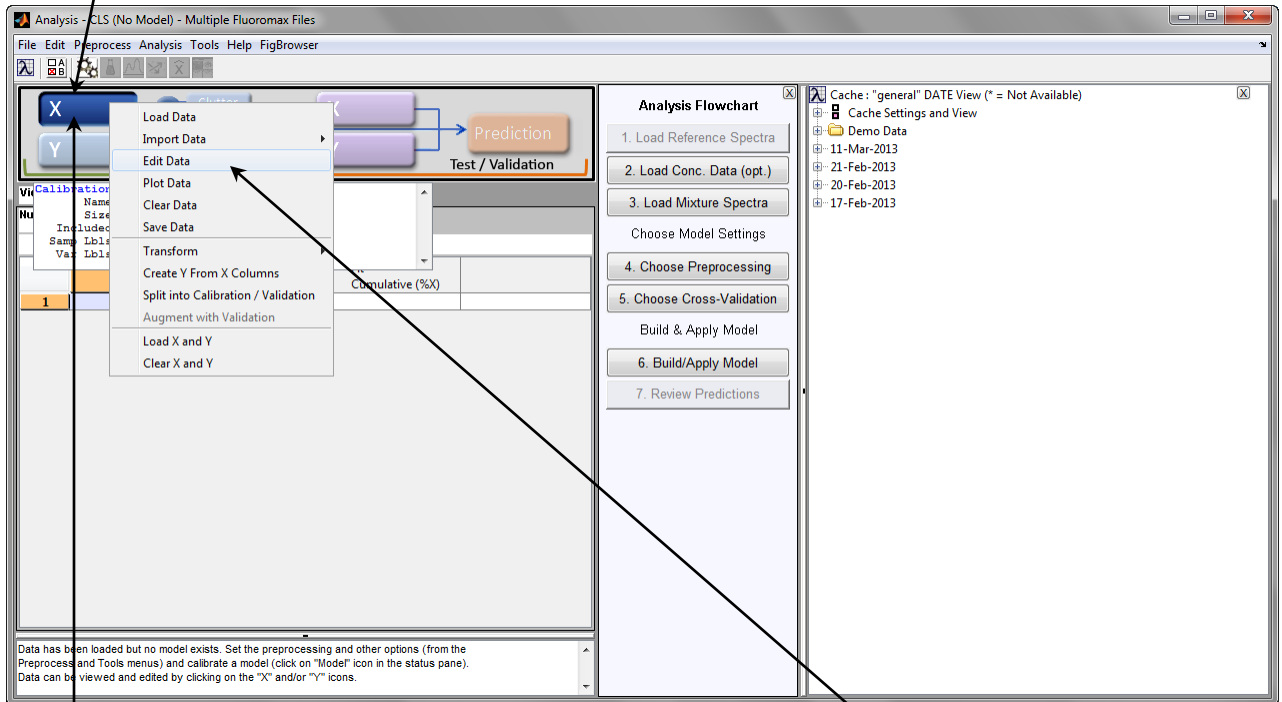

e Right-click the dark-blue X button.  
A menu appears.

f Choose Edit Data.  
The **DataSet Editor** window opens:

g In the toolbar, choose Transform.

h A menu appears.

i Choose Reshape.

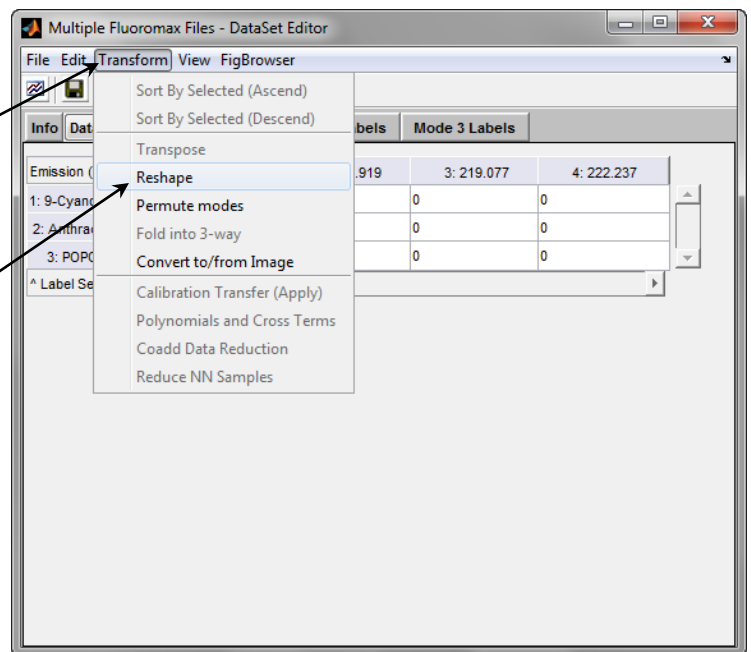

The **Reshape Data** window appears:

j As in previous procedures in this chapter, unfold the data by entering an asterisk as shown, then click the OK button.

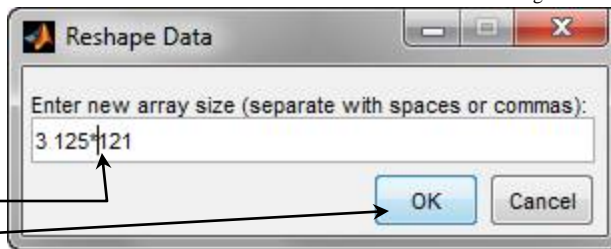

The **No Y-block** warning window appears.

k Click the Yes button to continue, or you may enter the concentration data manually by clicking the 2. Load Conc. Data (opt.) button.

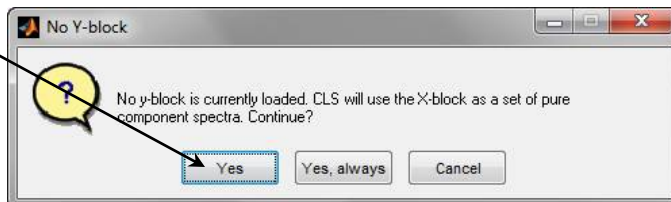

l The data are loaded.

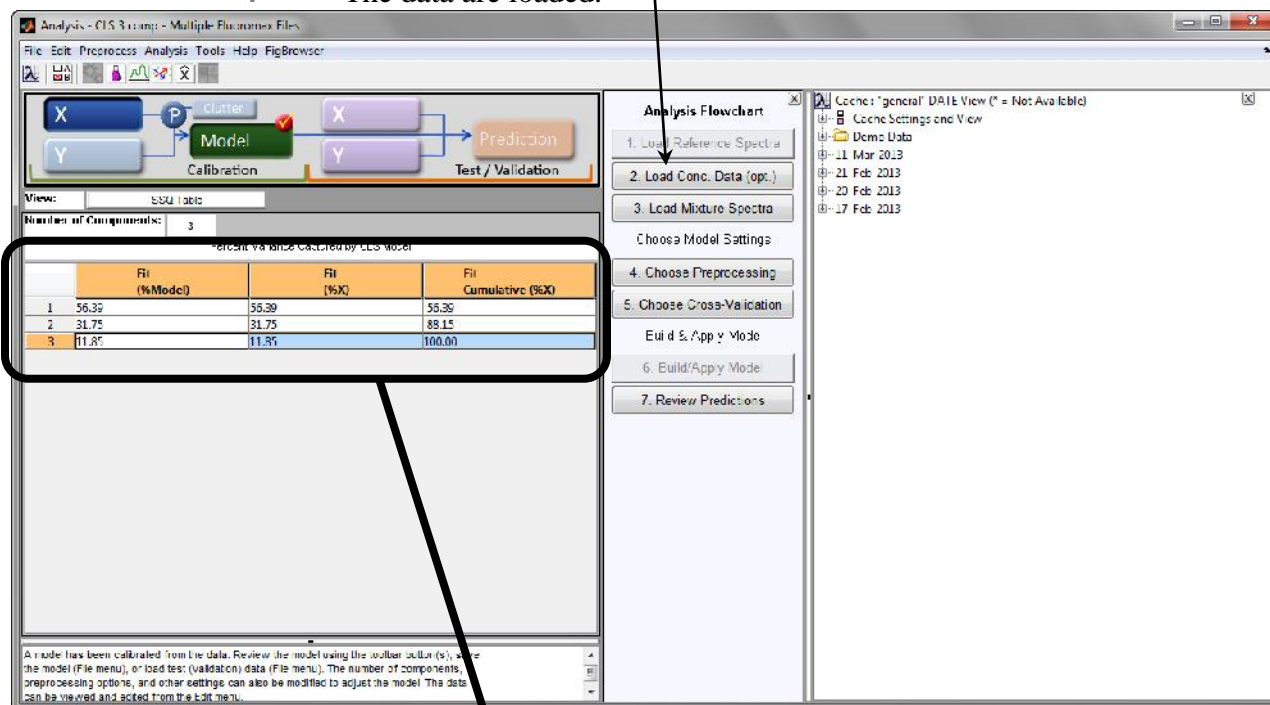

The fit appears in the **Analysis** window.

## 2 Load the validation data.

a Click the pale purple X button. The **Import** window appears again.

b As before, choose Horiba JY Aqualog File (DAT), and click the OK button. The **Select File to Open** window appears:

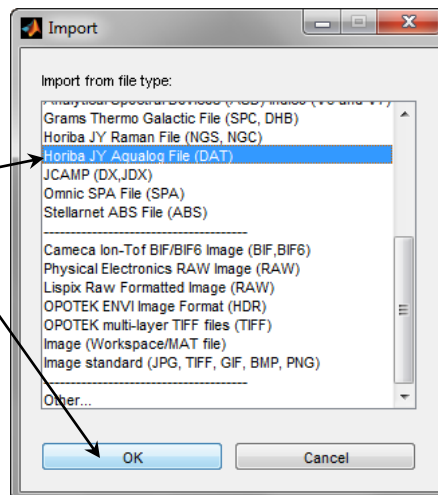



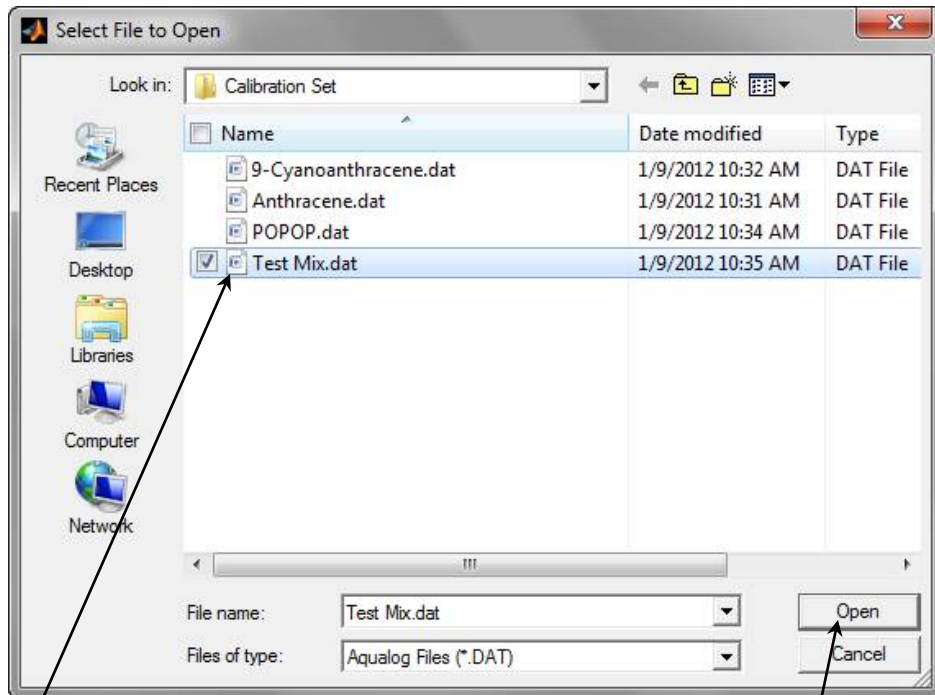

**c** Here we choose the mixture file to use for validation purposes, and click the Open button.

**d** Reshape the data as in Step 1, sub-steps f to l. The data are loaded as before.

### 3 Compare the model to the sample.

In the **Analysis** window, click the Prediction button:

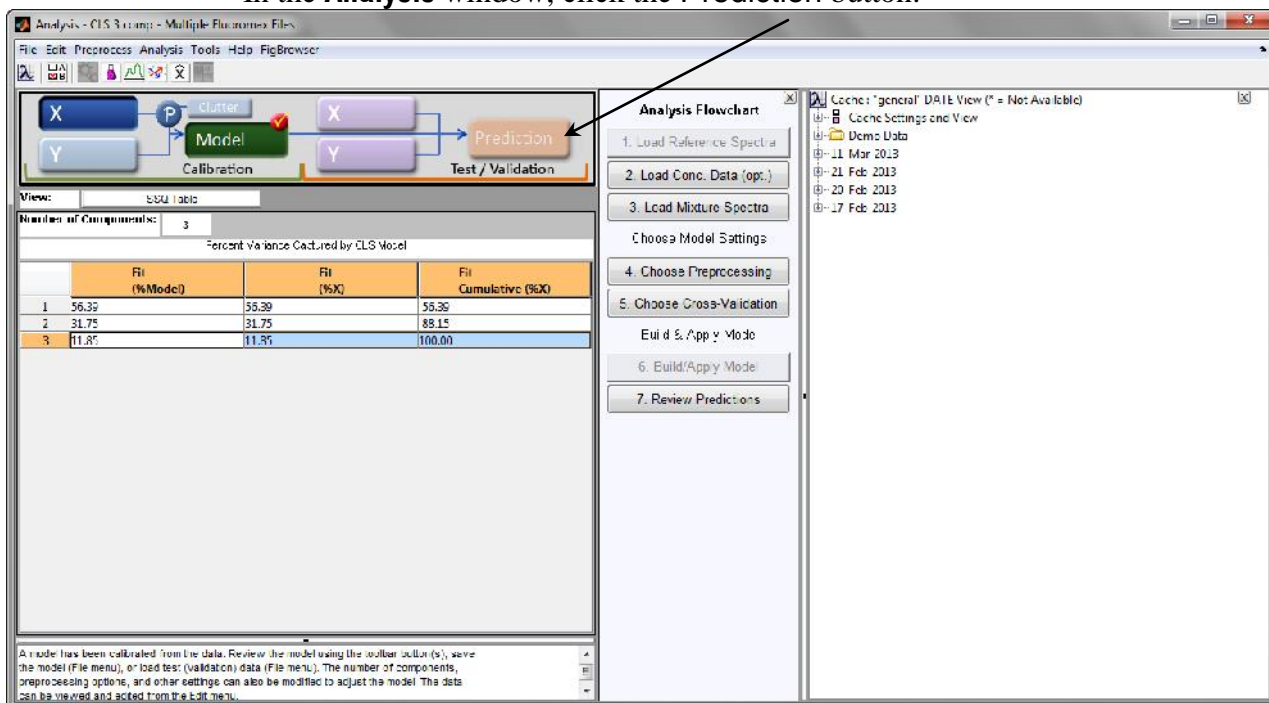

The Prediction button applies the calibration model to the mixture data.

# 4 View the comparison.

a Click the Plot Scores and Sample Statistics button .

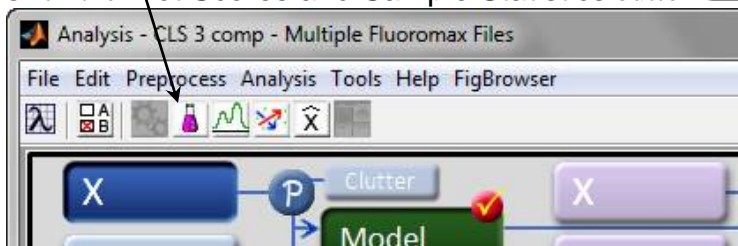

The **Plot Control** window and the data appear:

Ignore the Hotelling plot, in the upper-left corner. Instead, view the three other plots.

The black data points are the calibration samples; the red data points are the mixture (i.e., validation set).

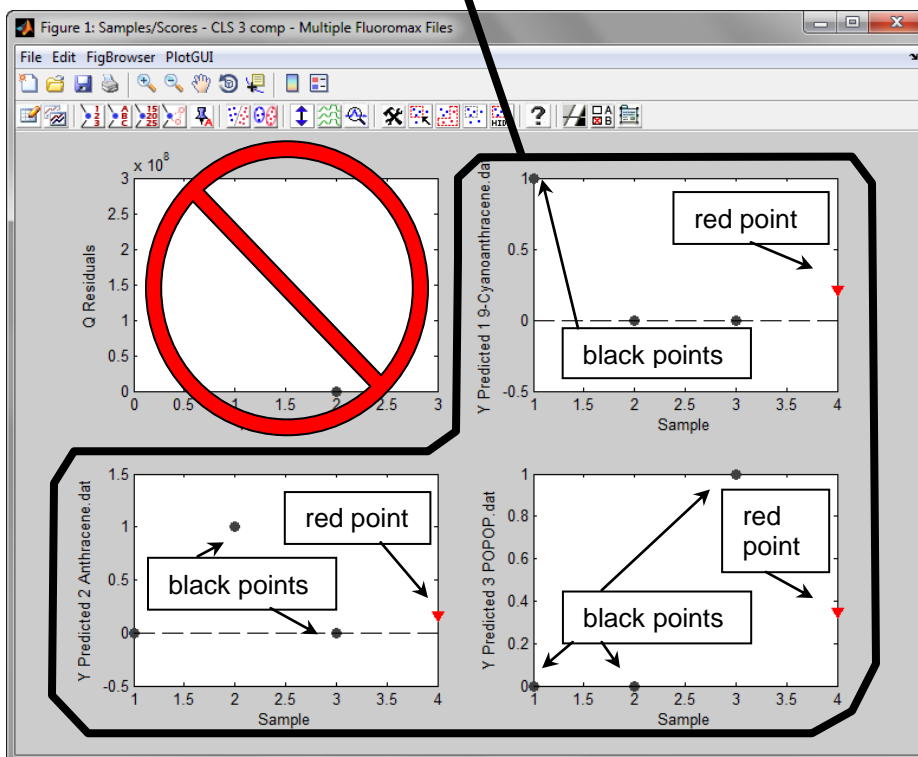
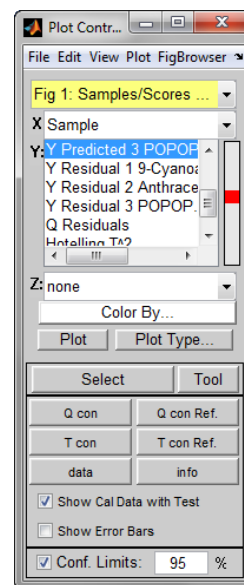



Now load the pure standard to prove this.

- b Import the pure standard using the purple X button, and reshape as before:

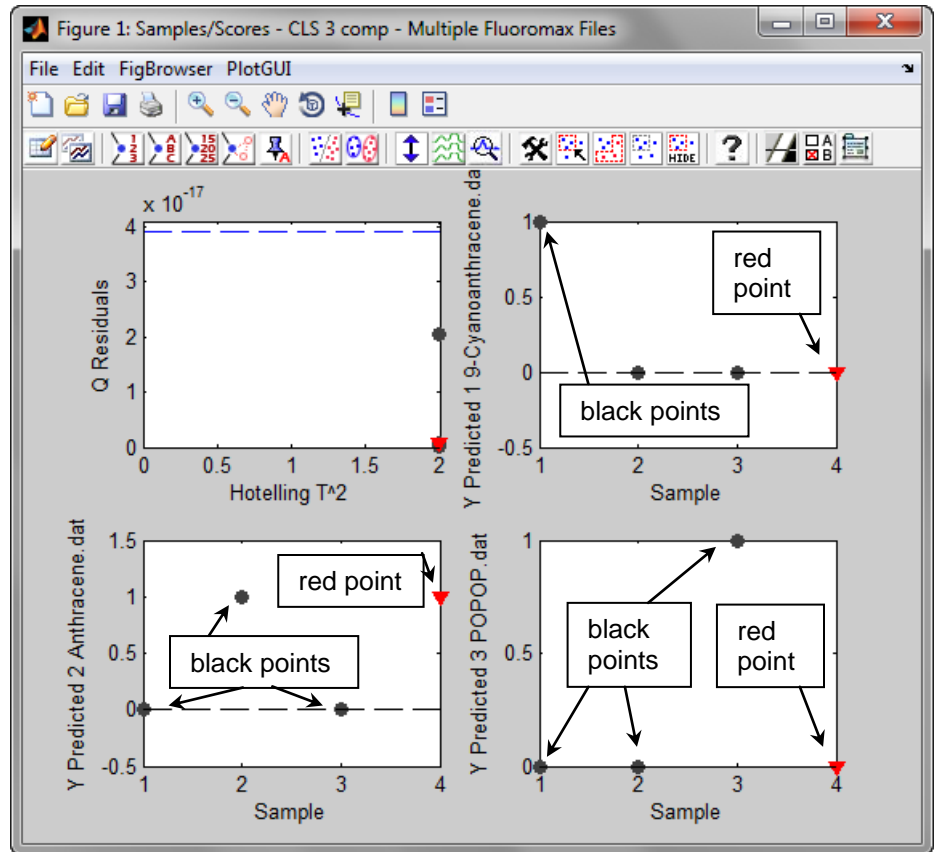



# 9: Optimizing Data

Spectra can be enhanced by optimization of data-acquisition. This chapter lists some methods of optimizing sample preparation, spectrofluorometer setup, and data correction to get higher-quality data.

## Cuvette preparation

1 Empty all contents from the cuvettes.

2 Fully immerse and soak the

cuvettes for 24 h in 50% aqueous nitric acid.

This cleans the cuvettes' inner and outer surfaces.

3 Rinse with de-ionized water.



4 Clean the cuvettes in the cleaning solution with a test-tube brush.

Use Alconox<sup>®</sup> or equivalent detergent as a cleaning solution.

5 Rinse the cuvettes with de-ionized water.

6 Soak the cuvettes in concentrated nitric acid.

7 Rinse them with de-ionized water before use.



**Note:** Clean the sample cells thoroughly before use to minimize background contributions.



**Warning:** Nitric acid is a dangerous substance. When using nitric acid, wear safety goggles, face shield, and acid-resistant gloves. Certain compounds, such as glycerol, can form explosive materials when mixed with nitric acid. Refer to the Materials Safety Data Sheet (MSDS) for detailed information on nitric acid.



**Caution:** Soaking the cuvettes for a long period causes etching of the cuvette surface, which results in light-scattering from the cuvettes.

# Sample preparation



**Caution:** Always read the Materials Safety Data Sheet before using a sample or reagent.

The typical fluorescence or phosphorescence sample is a solution analyzed in a standard cuvette. The cuvette itself may contain materials that fluoresce. To prevent interference, HORIBA Scientific recommends using non-fluorescing fused-silica cuvettes that have been cleaned as described above.

## Small-volume samples

If only a small sample-volume is available, and the intensity of the fluorescence signal is sufficient, dilute the sample and analyze it in a 4-mL cuvette. Correct absorbance readings require 1 cm path-length cells; reduced-volume cells are not supported. Inner-filter corrections also require 1 cm path-length cells.

## Solid samples

Solid samples usually are mounted in the 1933 Solid Sample Holder, with the fluorescence collected from the front surface of the sample. The mounting method depends on the form of the sample. See the section on “Highly opaque samples” for more information on sample arrangement in the sample compartment.

- Thin films and cell monolayers on coverslips can be placed in the holder directly.
- Minerals, crystals, vitamins, paint chips, phosphors, and similar samples usually are ground into a homogeneous powder. The powder is packed into the depression of the Solid Sample Holder (see next page for diagram). For very fine powder, or powder that resists packing (and therefore falls out when the holder is put into its vertical position), the powder can be held in place with a thin quartz coverslip, or blended with potassium bromide for better cohesion.
- A single small crystal or odd-shaped solid sample (e.g., contact lens, paper) can be mounted with tape along its edges to the Solid Sample Holder. Be sure that the excitation beam directly hits the sample. To keep the excitation beam focused on the sample, it may be necessary to remove or change the thickness of the metal spacers separating the clip from the block.



**Note:** Avoid thick coverslips, because the excitation beam may not hit the sample directly with a thick coverslip. Microscope coverslips are useful, except that they are not quartz, and do not transmit UV light.

## Dissolved solids

Solid samples, such as crystals, sometimes are dissolved in a solvent and analyzed in solution. Solvents, however, may contain organic impurities that fluoresce and mask the signal of interest. Therefore, use high-quality, HPLC-grade solvents. If background fluorescence persists, recrystallize the sample to eliminate organic impurities, and then dissolve it in an appropriate solvent for analysis.

## Biological samples

For reproducible results, some samples may require additional treatment. For example, proteins, cell membranes, and cells in solution need constant stirring to prevent settling. Other samples are temperature-sensitive and must be heated or cooled to ensure reproducibility in emission signals.

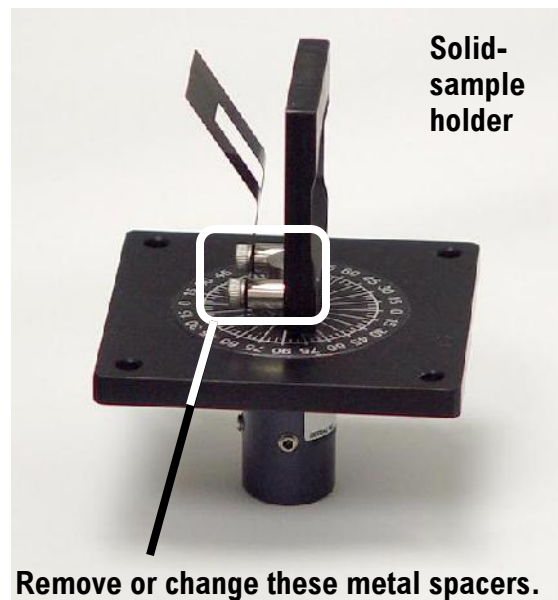

# Running a scan on a sample

## Precautions with the Solid-Sample Holder

Avoid placing the front face of the sample so that the excitation beam is reflected directly into the emission monochromator. If the sample is rotated at  $45^\circ$  from excitation, this may occur, increasing interference from stray light. Instead, set up the sample with a  $30^\circ$  or  $60^\circ$ -angle to the excitation, preventing the excitation beam from entering the emission slits. The photograph at right illustrates how a  $60^\circ$ -angle to the excitation keeps the incoming excitation light away from the emission monochromator's entrance.

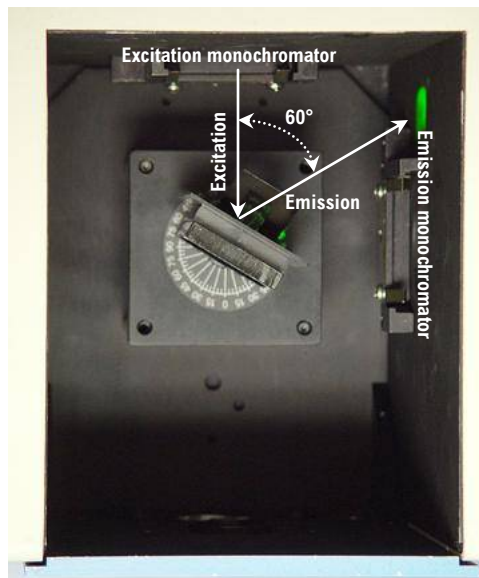

**Note:** The focal point of the excitation beam must be on the sample itself.

## Keep signal within detector's linear region

Be sure that the signal remains within the detector's linear region, so that the CCD does not saturate.

# Improving the signal-to-noise ratio

Because of various hardware or software conditions, occasionally it is necessary to optimize the results of an experiment.

The quality of acquired data is determined largely by the signal-to-noise ratio ( $S/N$ ). This is true especially for weakly fluorescing samples with low quantum yields. The signal-to-noise ratio can be improved by:

- Using the appropriate integration time,
- Summing together more accumulations,
- Changing the sample's concentration
- Binning more pixels together
- Increasing the gain on the CCD

The sections that follow discuss the alternatives for improving the  $S/N$  ratio and the advantages and disadvantages of each.

## Determining the optimum integration time

The length of time during which photons are counted and averaged for each data point is referred to as the *integration time*. An unwanted portion of this signal comes from noise and dark counts (distortion inherent in the signal detector and its electronics when high gain is applied). By increasing the integration time, the signal is averaged longer, resulting in a better  $S/N$ . This ratio is enhanced by a factor of  $t^{1/2}$ , where  $t$  is the multiplicative increase in integration time. For example, doubling the integration time from 1 s to 2 s increases the  $S/N$  by over 40%, as shown below:

For an integration time of 1 second,

$$\begin{aligned} S / N &= t^{1/2} \\ &= 1^{1/2} \\ &= 1 \end{aligned}$$

For an integration time of 2 seconds,

$$\begin{aligned} S / N &= t^{1/2} \\ &= 2^{1/2} \\ &\approx 1.414 \end{aligned}$$

or approximately 42%.

Because  $S/N$  determines the noise level in a spectrum, use of the appropriate integration time is important for high-quality results.

### To discover the appropriate integration time:

- 1 Find the maximum fluorescence intensity by acquiring a preliminary scan, using an integration time of 0.1 s.
- 2 From this preliminary scan, note the maximum intensity, and select the appropriate integration time from the table below.

Signal intensity (counts)	Estimated integration time (seconds)
100 to 1000	4.0
1001 to 5000	2.0
5001 to 50 000	1.0
50 001 to 65 535	0.1

Set integration time through **Experiment Setup** for a specific experiment, or **Real Time Control** to view the effects of different integration times on a spectrum. See the Aqualog<sup>®</sup> on-line help to learn more about setting the integration time.



## Scanning a fluorescent sample multiple times

Scanning a sample more than once, and averaging the scans together, enhances the  $S/N$ . In general, the  $S/N$  improves by  $n^{1/2}$ , where  $n$  is the number of scans.

**To scan a sample multiple times,**

- 1 Open the **Experiment Setup** window.
- 2 Specify the number of scans in the **Accumulations** field.

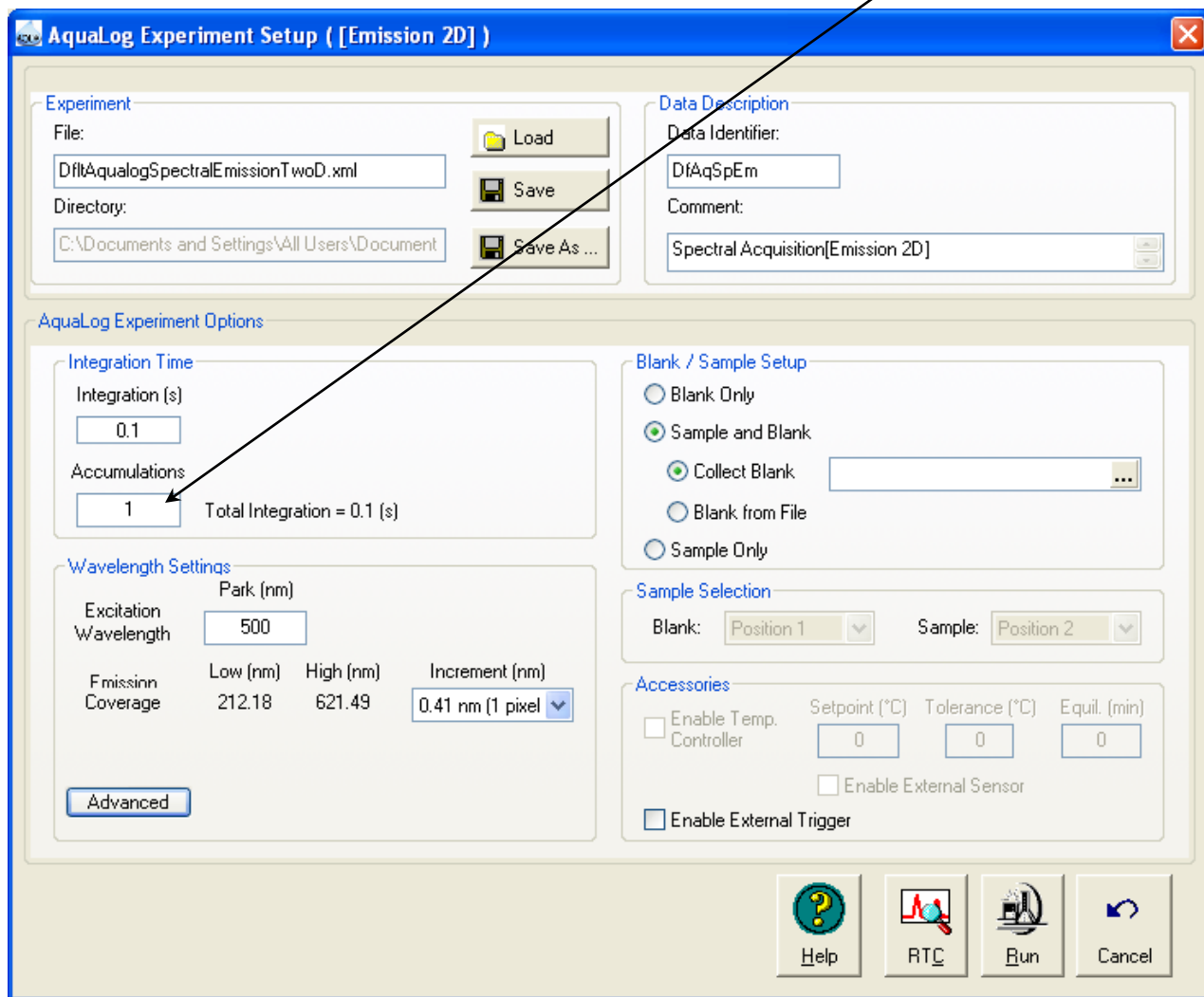

See Aqualog<sup>®</sup> on-line help for detailed instructions regarding the data-entry fields.

## Using the appropriate wavelength increment

The increment in a wavelength scan is the spacing, in nm, between adjacent data points. The spacing between the data points affects the resolution of the spectrum, and total time for acquisition. Consider the required resolution, time needed, and concerns about sample photobleaching. Most samples under fluorescence analysis display relatively broad-band emissions with a Lorentzian distribution, so they do not require a tiny increment.

In Aqualog<sup>®</sup> software, increments are measured in pixels, with a conversion to nm. A first try might be 0.82 nm increment. After acquiring the initial spectrum, examine the results. If two adjacent peaks are not resolved (i.e., separated) satisfactorily, reduce the increment to 0.41 nm. If the spectrum is described by an excessive number of data points, increase the increment, to save time and lamp exposure. A scan taken, using an increment of 0.41 nm, with a peak at full-width at half-maximum (FWHM) of 40 nm, should be characterized with a 1.64-nm increment instead. For optimal reduction of CCD readout noise relative to your required spectral resolution, we advise that you use the maximum binning (8 pixels) possible (the bandpass of the Aqualog is fixed at 5 nm). Please see discussion of CCD readout noise below (page 9-9).

For time-based scans, the increment is the spacing in s or ms between data points. Here, the consideration is the necessary time-resolution. The time increment dictates the total time per data point and for the scan in general. Set this value to resolve any changes in the luminescence of samples as they react or degrade. Time increments often range from 0.1–20 s.

You can change the increment using the Increment drop-down menu in the **Experiment Setup** window.

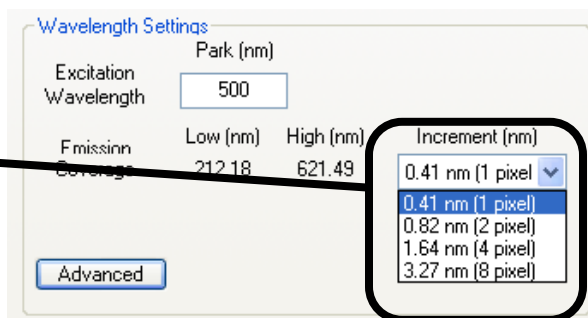

# Sources for instrument noise

## Gamma-ray spikes

These are occasional random spikes in the data, so collect data again, or remove the outlier.

## Stray scattered light in excitation/emission

This problem is caused by particles that scatter light in the sample. Therefore filter the sample, clean the sample cell, and avoid (bio)fouling.

## CCD saturation

Monitor message/Q log to see if the signal is beyond the linear region of the detector.

## CCD shot (Poissonian) noise

Increase count-rate up to saturation by increasing integration time or pixel-binning or both. The signal-to-noise ratio increases proportionally to the square-root of the number of electron counts. For example, if the signal  $S = 10\,000$  counts, noise = 100,  $S/N = 100$ . For  $S = 240\,000$  counts, noise = 489,  $S/N = 489$ .

## CCD dark noise

For a cooled CCD, this becomes less of a problem. Here, minimize the integration time, maximize the count rate, and optimize the gain. Consider that dark noise accumulates linearly with time.

## CCD readout noise

Every time you read a pixel, noise occurs. The lowest readout noise is at 3.28 nm (8 pixels/bin). Increase the pixel-binning up to the limits of your desired spectral resolution in order to separate your peaks in the spectrum.

In the case of resolution, the general formula is that a minimum of 2 pixels is required to resolve a peak. The Aqualog<sup>®</sup> bandpass is fixed at 5 nm. Therefore 3.28 nm is near the resolution limit and generally exceeds the half-width of CDOM peaks (typically are 20–30 nm FWHM).

# Optimizing Raman and QSU standards

## Misconception

Raman and quinine sulfate “intensities” should match exactly the CDOM fluorescence intensities and the measurement integration times. Not true!

But Raman and QSU signals are both primarily limited by shot noise; signal counts accumulate linearly with time.

QSU absorbance is very low, at 1 ppm (0.01384) so dilution could increase the error to below absorbance error specification (0.001). The quantum yield for quinine sulfate, 55%, is at least ten times higher than CDOM.

## Recommended practice

- 1 Get the best  $S/N$  for determining the value of the normalization factor (RSU or QSU)**

Integrate the signals with matching CCD bin and gain settings (as CDOM sample) up to CCD saturation.

- 2 Then divide the normalization intensity factor by the integration time for the sample and normalization standard, to get the most accurate normalization factor.**

Otherwise the uncertainty in the factor propagates into the value of the signal. Use the QSU and RSU tools to match the QSU or RSU factors to the EEM binning and integration time.

# Suggestions for best use of the Aqualog<sup>®</sup>

## Keep the signal in the detector's linear range

Know the CDOM concentration to avoid exceeding the Beer-Lambert linearity for IFE correction. Use the Single Point Absorbance experiment to measure A254 (A450) for samples, in order to establish an acceptable signal range and evaluate the linearity of dilution if necessary.

## Keep the cuvette clean

Use the sample only EEM experiment, then apply the Rayleigh masking tool followed by the profile tool to integrate axes, and evaluate presence of signals above the zero baseline.

## Choose the correct integration time

Avoid saturation and under-accumulation of signals. Sort samples by their A254 value, and pre-determine best integration times, to achieve peak counts between 3000 and 15 000 in S1c/R1c signal of the EEM. You usually can do this with a 2D Emission experiment exciting at 254 nm. Then program each batch of sample into separate Q integration-time experiments.

## Establish wavelength settings for excitation and CCD bin and Gain.

Default recommendations as above include excitation from an absorbance value below the IFE linearity limit (typically 200–240 nm). This depends on salinity (i.e., UV extinction) and interfering compounds with iron, etc. Bin the CCD at 4–8 pixels, but weak samples are better with 8. The Gain is usually best at Medium. High gain is not ideal for long integration times because of amplified accumulation of dark noise.

## Use solvent-matching

Solvent matrix-effect differences for blank and sample can lead to incomplete Raman subtraction and Rayleigh masking. Therefore, match solvents for refractive indices and salinity conditions (especially the UV cutoff). Use appropriate Rayleigh mask-widths (usually 10–20 nm) for scattering samples to completely eliminate the scatter edges, which are multiplied by IFE correction. The Solo software removes Raman signals as a supplemental nullification mask after Aqualog<sup>®</sup> blank-subtraction.

## Determine normalization factors for sample Q or EEM experiment

Determine the optimal RSU or QSU using matching CCD bin and gain settings. Adjust the factor for the difference between the sample (Q) experiment integration time, and entered into the normalization tool or Q entry field.

## Validate the instrument with the samples at appropriate intervals

HORIBA Scientific advises you to monitor the water Raman *S/N* and or the QSU test using the Starna RM samples at least once a week per operation. These sample tests validate absorbance/excitation and emission calibration as well as instrument throughput.

The NIST SRMs for emission, excitation and absorbance probably will not need re-checking until lamp replacement (1000 hours or 50% intensity loss) and even then likely will not require recalibration or correction. HORIBA Scientific recommends that re-correction is performed or assisted by trained Aqualog service personnel.

## Configure excitation scanning range, interval, and emission binning for IFE correction and PARAFAC

The absorbance scan range should include excitation and emission ranges, typically 200 (240)–800 nm (depending on Aqualog<sup>®</sup> model), because IFE includes both primary and secondary effects. Closely match the excitation intervals and bin settings for two reasons:

- 1) PARAFAC equally weighs excitation and emission spectra so resolution should be symmetrical, and
- 2) Absorbance data for IFE should match fluorescence intervals to eliminate problems with interpolations of sharp peaks and valleys common in many compound spectra.

## Use the appropriate tools to collect multiple data-sets

Special tools are needed to use the multi-position sample changer, autosampler, or continuous (stopped) flow system, or to collect multiple EEMs without overfilling project files. Use the sample Q tool to configure sample changer for the 2- or 4-position sample changer, or enable external triggering to coordinate with the autosampler or flow system.

# 10: Maintenance

## Introduction

The Aqualog<sup>®</sup> requires little maintenance. To remove dust and fingerprints, wipe the outside panels with a clean, damp cloth. The lamp is the only component that must be replaced routinely. For the Aqualog<sup>®</sup>-UV, the charcoal filters also must be replaced, generally when the lamp is replaced. Regular examination of the xenon-lamp scan and water Raman spectrum serves as early indicators of the system's integrity. See Chapter 3 for these tests.

## Lamp replacement

### When to replace the lamp

Obtaining good spectral results depends on the xenon lamp. The Aqualog<sup>®</sup> keeps track of lamp usage automatically. After 1000 h of use, a **Lamp hours** warning notice appears on the host computer's monitor after you initialize the Aqualog<sup>®</sup>:

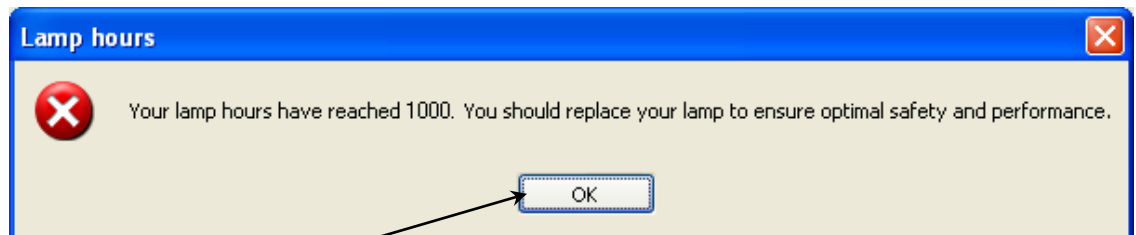

Click the OK button to acknowledge the message. Replacing the lamp within the recommended time may prevent a catastrophic failure. Each time the lamp is turned on constitutes one full hour of use. Therefore, HORIBA Scientific suggests leaving the lamp on during brief periods of inactivity.

### Parts and tools required

The replacement xenon lamp is packed in the manufacturer's box. Read all instructions and precautions before removing the lamp from the protective cover, and inserting it into the Aqualog<sup>®</sup>.

- Phillips screwdriver
- 3/32" Allen key
- 7/64" Allen key
- 1/8" Allen key
- 9/64" Allen key



**Warning:** Do not remove the protective cover from the replacement lamp until instructed to do so.



## Hazards

- Xenon-arc lamps are an explosion hazard. Wear explosion-proof face-shield and protective clothing when opening the lamp housing and handling the lamp.
- Disconnect the lamp power supply from the AC power line (mains) while handling lamp leads. Lethal high voltages may exist.
- The lamp remains extremely hot for approximately one hour after it has been turned off. Do not touch the lamp or the metal unit until the lamp has cooled.
- Never look directly at the xenon arc or its reflection. Intense radiation can permanently damage eyes.
- Do not touch the focusing lens, back-scatter mirror, or the surface of the lamp. Fingerprints will be burned onto these surfaces when the lamp is ignited.



## Changing the lamp

- 1 Switch off and prepare the Aqualog<sup>®</sup>.
  - a Be sure that the Aqualog<sup>®</sup> and the host computer are turned off, and that the lamp has completely cooled.
  - b Remove the AC (mains) power cord from the Aqualog<sup>®</sup>.
  - c Disconnect the USB cable, power cord, and any other cables attached to the spectrofluorometer.
- 2 Gently remove the sample mount from the front of the Aqualog<sup>®</sup>.

The standard Aqualog<sup>®</sup> front is held via a friction fit, with no screws to remove. Some accessories require removal of 4 screws. Some sample mounts also have a 15-pin connector at the inside end for automated accessories.





### 3 Remove the lamp cover.

- a With an Allen key, remove the three screws from inside the left wall of the sample compartment.



- b With the Allen key, remove the three screws from inside the right wall of the sample compartment.

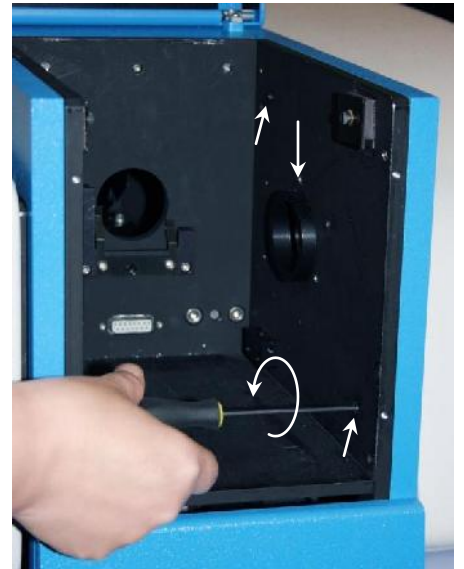

- c Pull the left half of the chassis cover to the left.



- d Pull the right half of the chassis cover to the right.

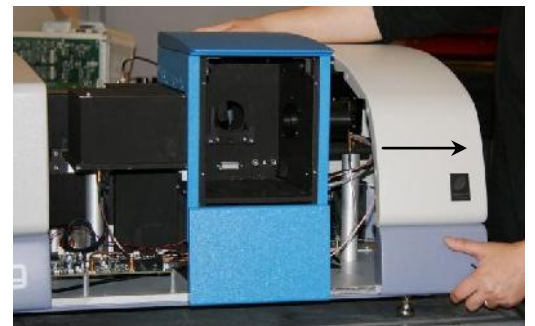

There should be a gap wide enough to completely expose the lamp housing:

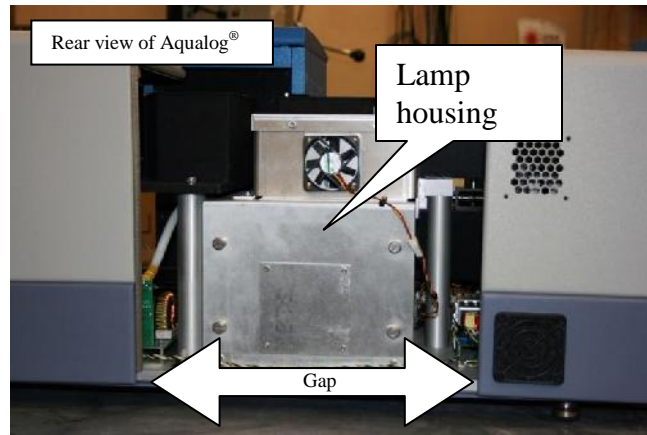

## 4 Remove lamp housing.

a Disconnect the fan cable.

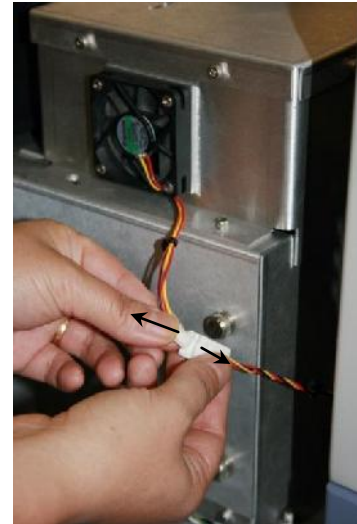

b Loosen the four spring-loaded screws on the lamp housing.



- C Remove the cover of the lamp housing.



- d Tilt the instrument upward enough to remove the bolt from underneath the chassis.



**Loosen the bolt.**



**Remove the bolt.**

- e With an Allen key, remove the two locking screws from the baseplate.



- f Lift the lamp mount up, then out of the instrument.

Be aware of the two alignment pins that fix the underside of the mount to the instrument.

The lamp is held in place by spring tension and the height adjustment on top of the lamp. The anode and cathode connections are attached to the lamp via thumbnuts on top and bottom of the lamp.

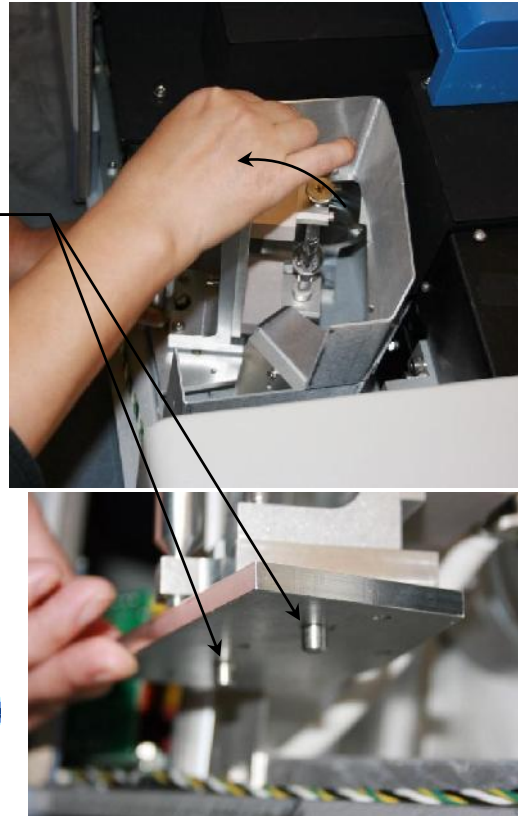

**Warning:** Wear protective gloves whenever handling xenon bulbs.

## 5 Prepare the replacement lamp.

- a Place the new xenon bulb (still in its protective cover) nearby.
- b Open the new bulb's protective cover. Keep this cover handy for later.

## 6 Remove the old xenon lamp.

- a Loosen the top and bottom thumbnuts on the lamp electrodes. Remove the nuts and washers. There are two washers for each thumbnut.





- b With an Allen key, loosen the left screw on the retainer bracket.

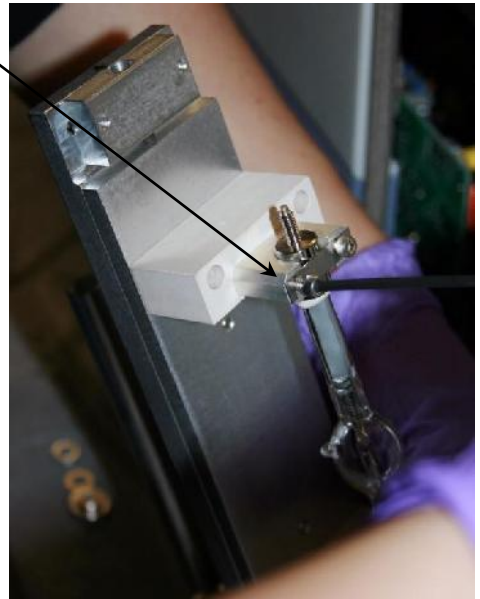

- c Raise the retainer to free the bulb.



- d Lift bulb out.



**Caution:** Improper connections to the lamp severely affect lamp performance and affect the power supply. Carefully note the anode and cathode connections to the lamp. The anode (+) is on top; the cathode (-) is on the bottom. The nipple on the lamp's glass envelope marks the anode (+) side.



- 7 Place the old lamp in the protective cover from the new lamp.
- 8 Put the old lamp (inside the protective cover) in a safe place.
- 9 Install the new lamp.



**Warning:** Do not touch any portion of the lamp except the metal cathode and anode.

- a Write down the serial number of the lamp, found etched on the anode end of the bulb:

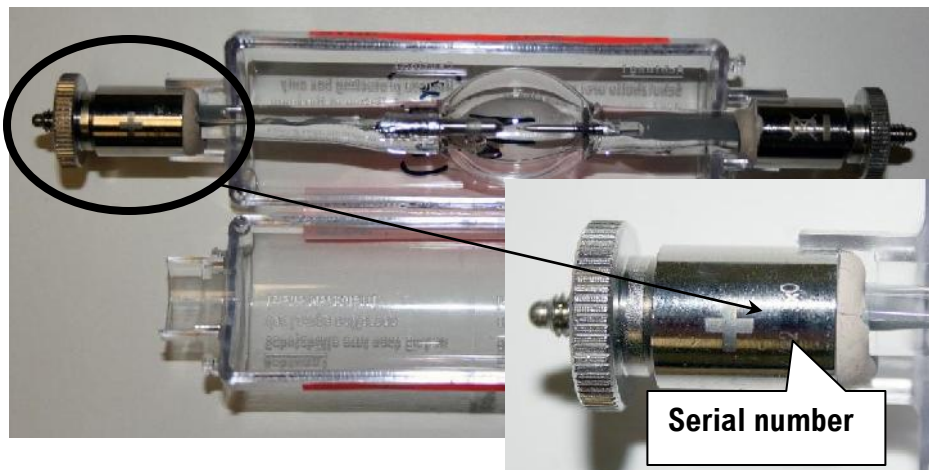

- b Insert the bulb with anode at the top, pointy electrode upward, and the nipple towards the left (out of the optical path).

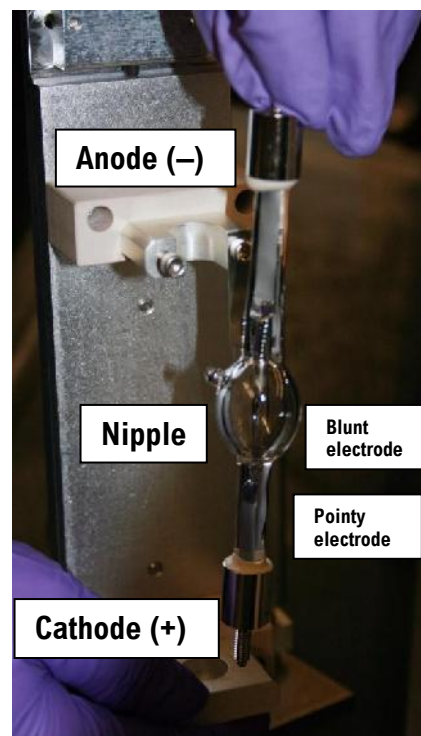

c Drop retainer into position.



**Note:** Keep the nipple facing left, out of the optical path.

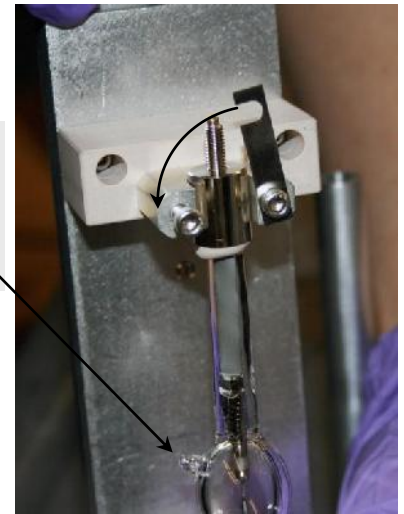

d Tighten retaining screw with Allen key.

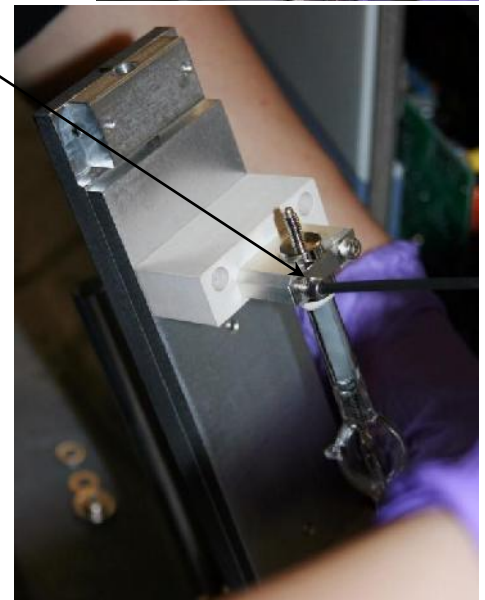

e Place each cable connector between two washers, thread onto correct electrode, and affix with thumbscrew. Tighten the thumbscrew by hand.



**Note:** Keep the electrode cables pointed to the right, and the nipple to the left.

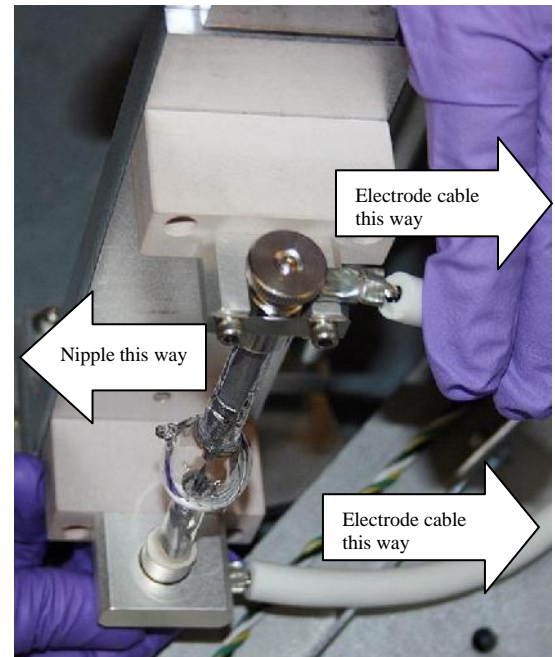

- f Line up pins on underside of lamp mount with holes in baseplate. Replace lamp mount in instrument.

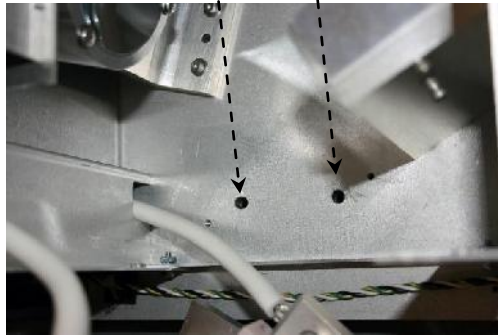
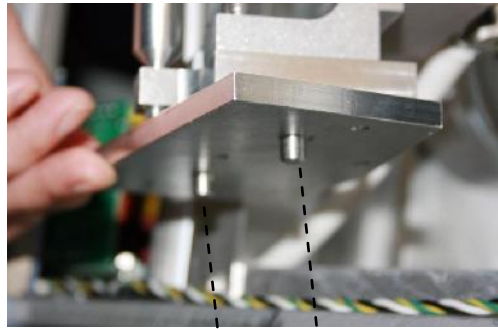

**Note:** Be sure the lamp mount is completely flat against the baseplate.



The electrode cable should be underneath the cover.





- g Replace the two locking screws.



- h Tilt the instrument back far enough to replace the hex bolt underneath the chassis.



*Note: Don't tighten the bolt yet!*



- i Re-install the cover.

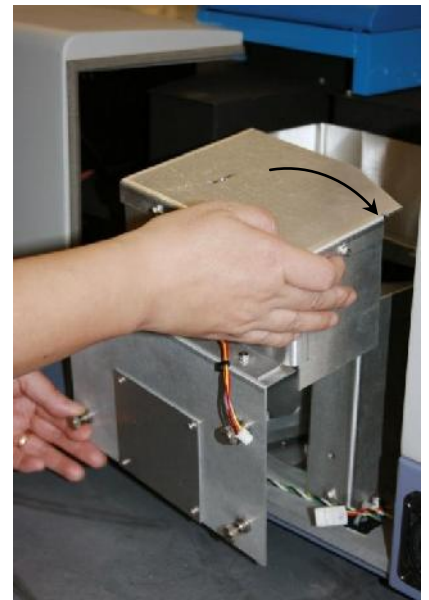

- j Hand-tighten the four spring-loaded screws.

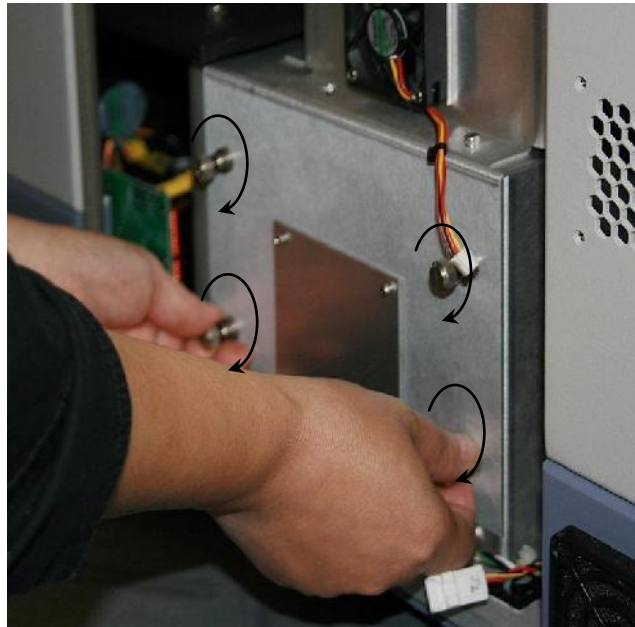

- k Reconnect the fan cable.



## 10 Reconnect all cables (power, communications, accessories, etc.) to the Aqualog<sup>®</sup>.



**Note:** Do not replace the Aqualog<sup>®</sup> covers until the lamp is correctly adjusted.

# 11 Reset the hour-meter.



**Caution:** Intense ultraviolet, visible, or infrared light may be present, so wear eye- and skin-protection, such as light-protective goggles and light-blocking clothing.

- a With the chassis still removed, turn on the Aqualog®.
- b Insert a fluorescence sample with a known emission peak in the sample compartment, and close the sample-compartment lid.



**Note:** This example uses Rhodamine 6. You may choose another sample, whose peaks and signal may vary.

- c Let the lamp warm up for at least 30 min.
- d In the Windows® Start menu, choose All Programs, then Jobin Yvon, then Utilities, then Lamp Reset.

The **Aqualog Configuration** window appears:

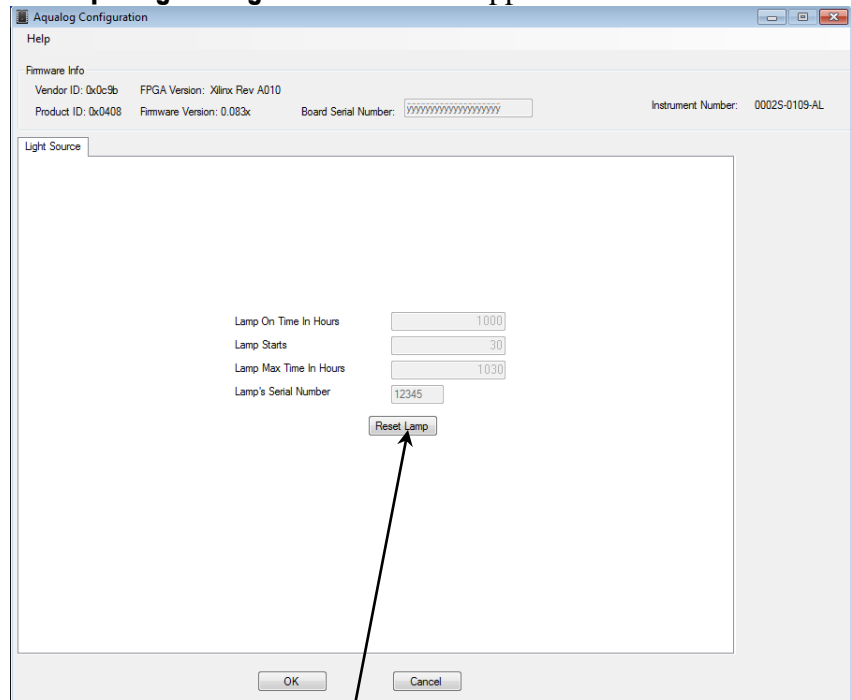

- e Click the Reset Lamp button.

- f The **Lamp Info** window appears.  
 Enter the new bulb's serial number that you noted down previously, then click the OK button.  
 The **Lamp Info** window closes, and the **Aqualog Configuration** window resets its values.

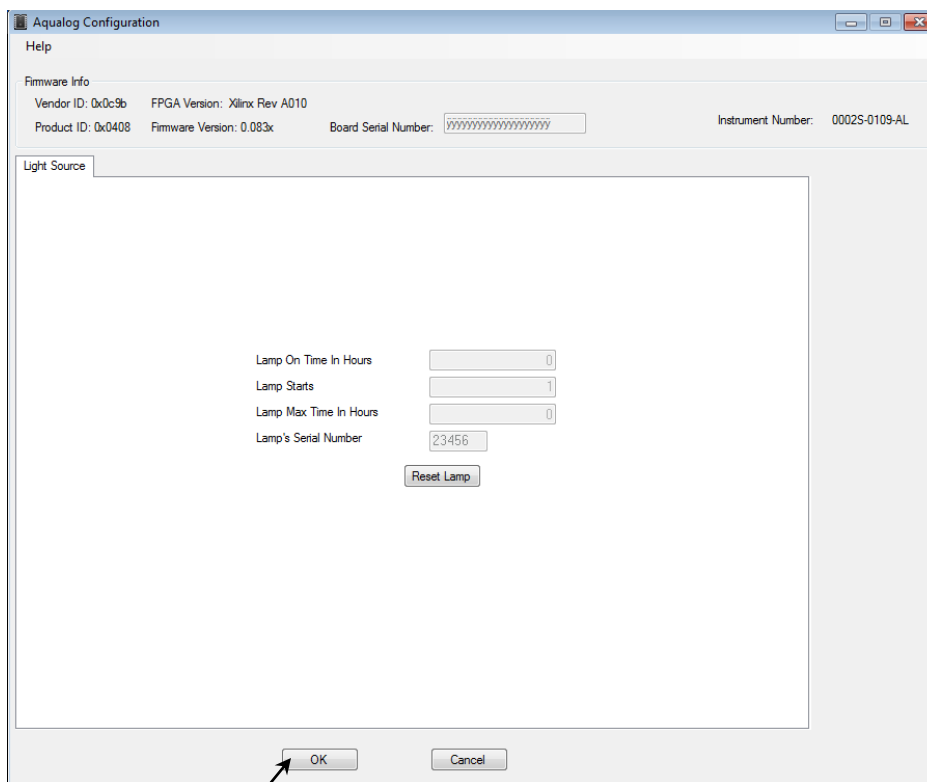
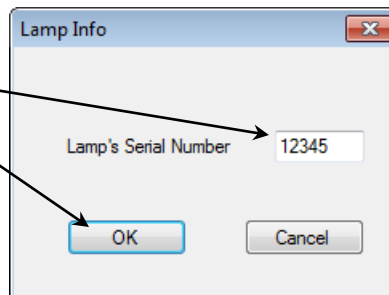

- g Click the OK button to finish.  
 The **Aqualog Configuration** window closes.

## 12 Adjust the new xenon lamp.

- a Start the Aqualog<sup>®</sup> software.  
 b In the main window, choose Collect\Advanced Setup\System Reinitialization.  
 The Aqualog<sup>®</sup> initializes, then the **Aqualog Main Experiment Menu** appears.  
 c Choose Spectra.

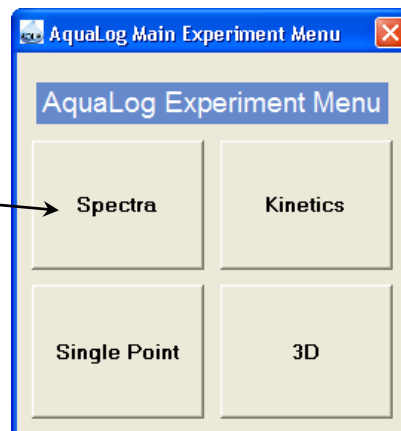

- d The **Aqualog Experiment Type** window appears.
- Click Emission 2D, then click the **Next >>** button.

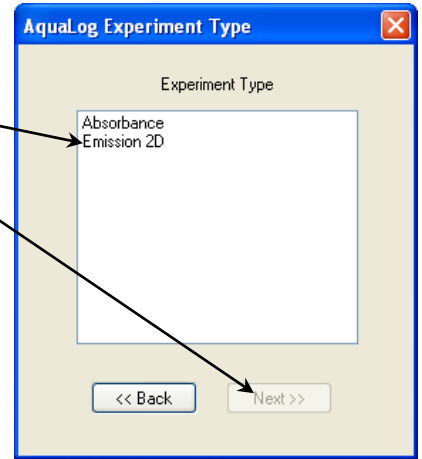

The **Experiment Setup** window appears:

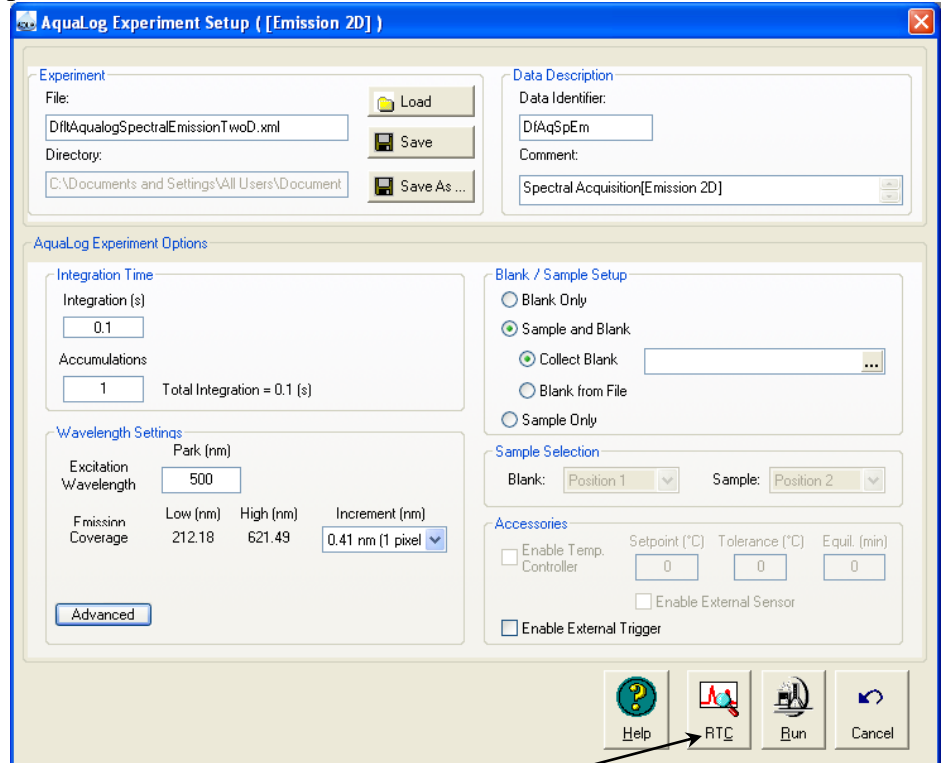

- e Click the **RTC** button to open the **Real Time Control**:

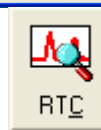

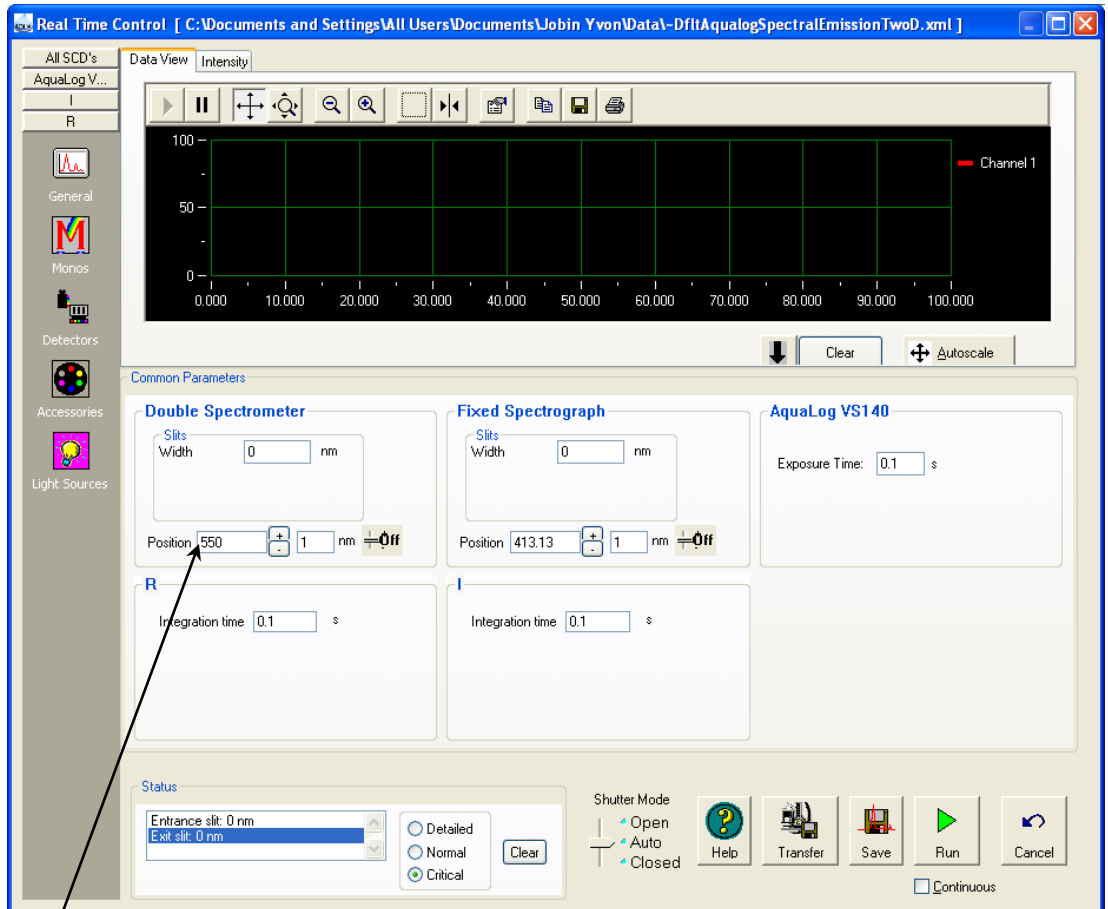

- f In the Double Spectrometer area, enter the excitation wavelength appropriate for your sample in the Position field. In this example, we will excite the rhodamine 6 at 550 nm, so we enter 550 nm.

g Choose the Aqualog V... tab to adjust the emission detector's parameters:

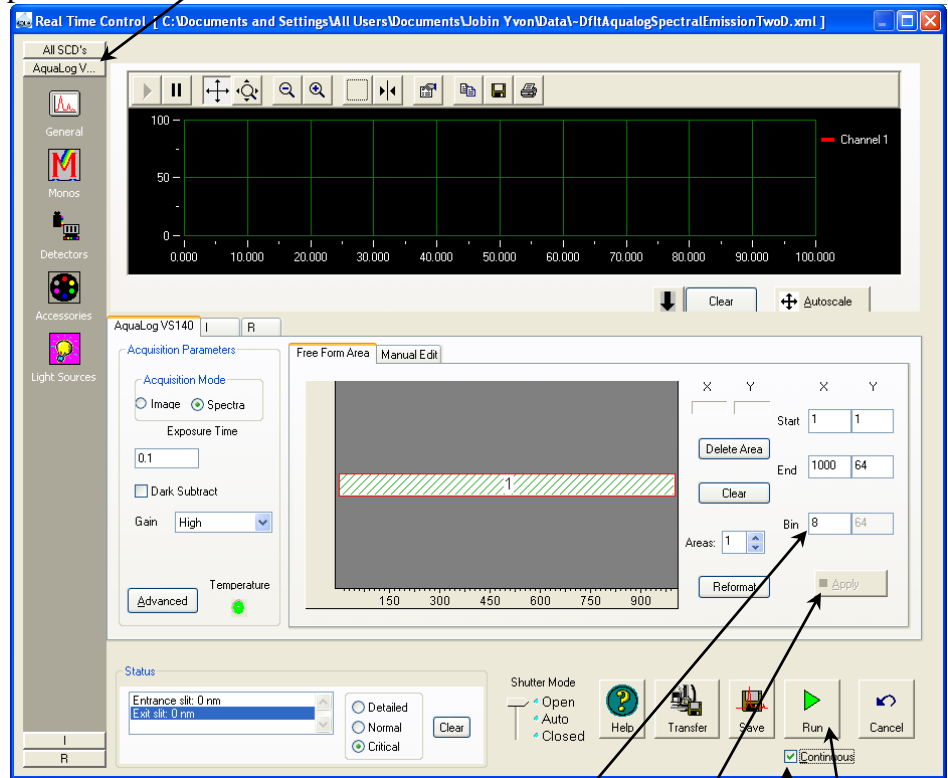

h Set the Bin to 8, to shorten the integration time.

i Click the Apply button.

j Activate the Continuous checkbox to take data continuously.

k Set the Shutter Mode slide-switch to Open.



l Click the Run button to start the scan.  
The instrument starts scanning.

m Just below the graph area, click the ↓ button to expand the plot:

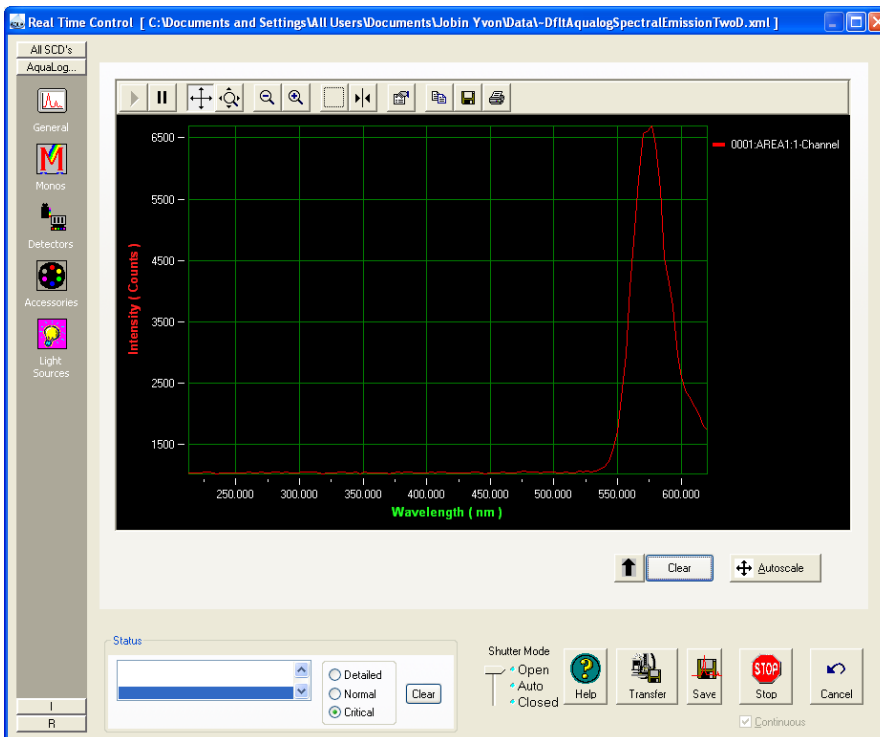

n On the back of the lamp housing, insert an Allen key to loosen two internal set screws:

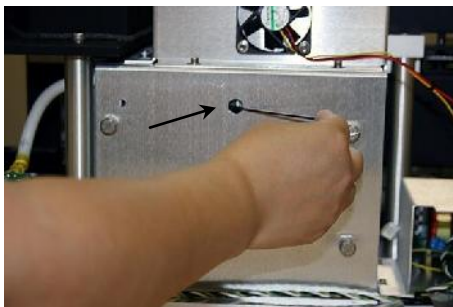

Loosen the left internal screw.

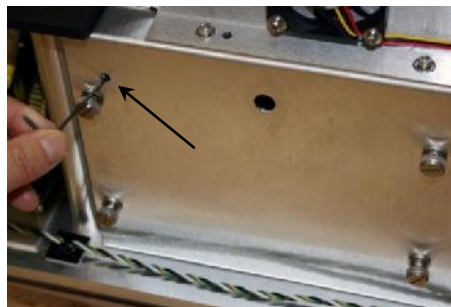

Loosen the right internal screw.



**Note:** These screws must be loosened, otherwise the bulb is not adjustable.

o Adjust the xenon lamp's height using a 5/64" Allen key. While turning the key, watch the signal intensity on the **Real Time Control** display, and try to maximize the signal.

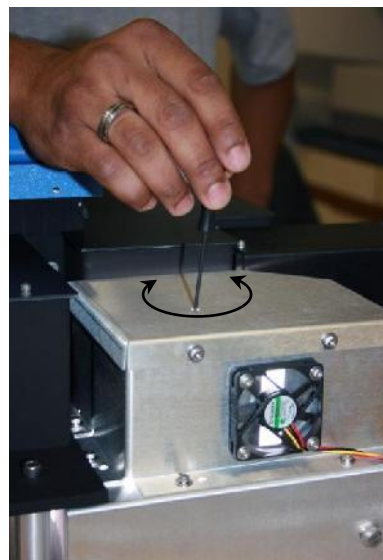



- p Adjust the xenon lamp's centering using a 5/64" Allen key:  
While turning the key, watch the signal on the **Real Time Control** display, and try to maximize the signal.

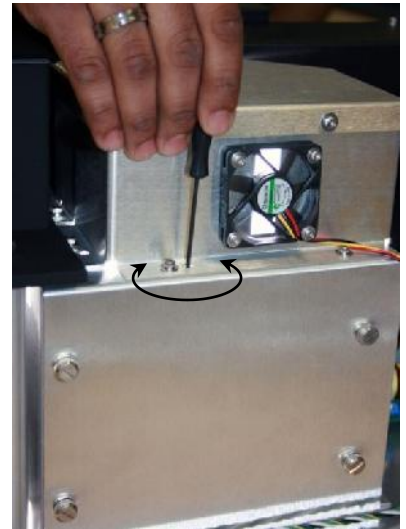

- q Adjust the xenon lamp's focus using a 5/64" Allen key.  
While turning the key, watch the signal on the **Real Time Control** display, and try to maximize the signal.

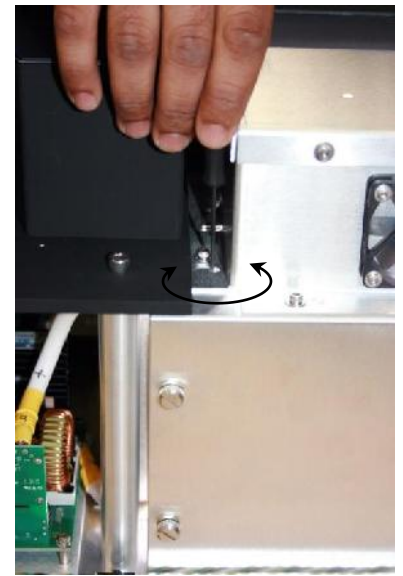

- r When optimized, click the **Cancel** button, turn off the instrument, tighten the internal set screws on the housing, and unplug all external cables.

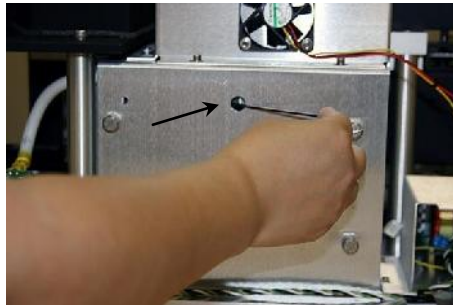

Tighten the left internal screw.

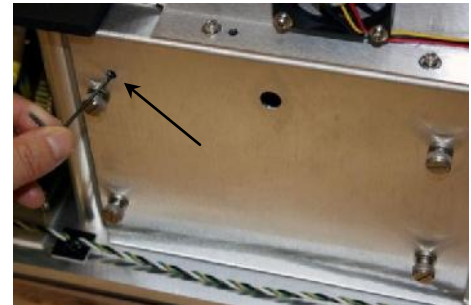

Tighten the right internal screw.

## 13 Finish closing the instrument.

- a Let the lamp and instrument cool at least 20 min, then raise the chassis enough to tighten the bolt underneath. This locks the alignment of the new bulb.

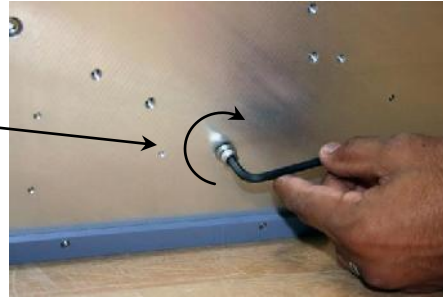

- b Slide the left and right covers closed.



- c Reconnect all cables (power, communications, accessories, etc.) to the Aqualog<sup>®</sup>.

# Changing the charcoal filters on the Aqualog<sup>®</sup>-UV

## Introduction

The UV-enhanced lamp within the Aqualog<sup>®</sup>-UV spectrometer produces a minor amount of ozone. Therefore, for safety, all ventilation ports on the Aqualog<sup>®</sup>-UV's chassis contain charcoal filters to absorb the ozone as the air leaves the instrument.

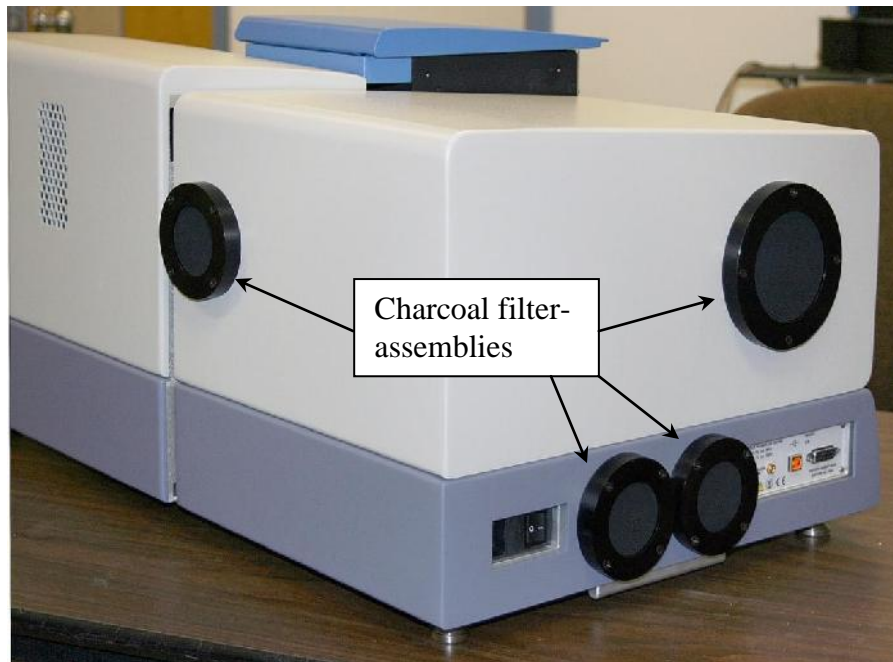

These four charcoal filters become saturated with time, and thus must be changed on occasion. HORIBA Scientific recommends that you change the charcoal filters when you change the lamp, after every 1000 hours of use. At that time, the internal hour-meter on the Aqualog<sup>®</sup>-UV activates the **UV Filter Warning** window on the host computer's monitor:

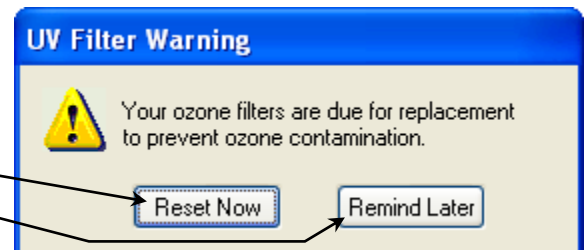

Click the **Reset Now** button to change the filters now, or the **Remind Later** button to change the filters at a later time. If you do not change the filters now, the **UV Filter Warning** window will appear each time you restart the instrument. When you click the **Reset Now** button, the Aqualog<sup>®</sup>-UV's internal hour-meter resets to 0 hours.

## Parts required

Aqualog UV filter kit (J356947)  
Phillips screwdriver

## Method

- 1 Be sure that the instrument is switched off and unplugged from the AC (mains) outlet.
- 2 Change the lamp if required.
- 3 With a Phillips screwdriver, remove the four screws that hold each filter-assembly to the chassis.

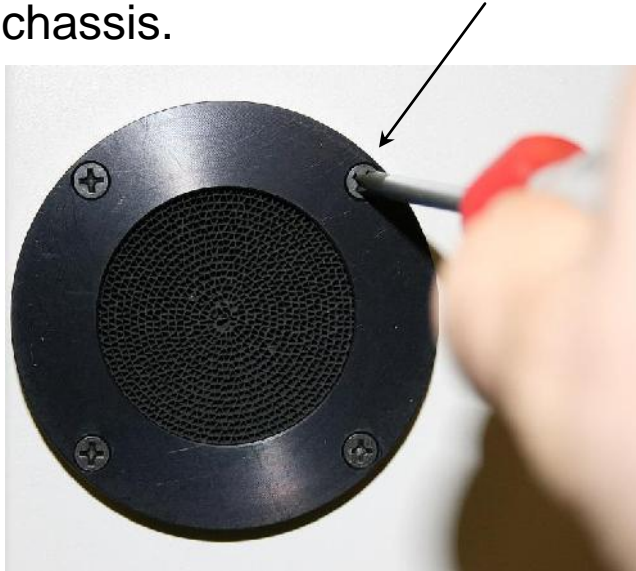

- 4 Remove the filter from each assembly.



- 5 Put a new filter in each assembly.
- 6 Re-attach each filter-assembly to the chassis with four screws.
- 7 Dispose of the spent filters properly.

# 11: Components & Accessories

Accessories for the Aqualog<sup>®</sup> can be added to obtain optimum results for a variety of applications. The following list represents all the accessories and components, in alphabetical order, available for the Aqualog<sup>®</sup> spectrofluorometers. A brief description of each is included. Like the list presented below, the descriptions that follow are alphabetized, except where logical order dictates otherwise.

For additional information or product literature on any of these items, contact your local Sales Representative.

# Itemized list of Aqualog<sup>®</sup> accessories

<b>Item</b>	<b>Model</b>	<b>Page</b>
Assembly, liquid-nitrogen Dewar	FL-1013	12-3
Cell, HPLC flow	J1955	12-4
Cell, quartz	1925	12-4
Cell, sample	1920	12-4
Fiber-optic mount	F4-3000	10-5
Fiber-optic bundles	1950	10-5
Holder, four-position variable temp. control w/ magnetic stirrer	FL-1011	10-6
Holder, dual-position variable temp. control w/ magnetic stirrer	FL-1012	10-8
Holder, single-position variable temp. control w/ magnetic stirrer	FL-1027	10-10
Holder, solid-sample	J1933	10-12
Lamp, xenon replacement, 150-W	1905-OFR	10-14
Port, injector	FL-1015	10-15
Temperature bath	F-3030	10-16



# FL-1013 Liquid Nitrogen Dewar Assembly



**Caution:** Refer to your Material Safety Data Sheet (MSDS) for information on the hazards of cryogenic materials such as liquid nitrogen.

For phosphorescence or delayed fluorescence measurements, samples are often frozen at liquid-nitrogen temperature (77 K) to preserve the fragile triplet state. The sample is placed in the quartz cell and slowly immersed in the liquid-nitrogen-filled Dewar flask. The white Teflon<sup>®</sup> cone in the bottom of the Dewar flask keeps the quartz sample-tube centered in the Dewar flask. The Teflon<sup>®</sup> cover on the top of the Dewar flask holds any excess liquid nitrogen that bubbled out of the assembly. A pedestal holds the Dewar flask in the sampling module. A special stove-pipe sample cover replaces the standard sample lid, so that liquid nitrogen can be added to the Dewar flask as needed. The Dewar flask holds liquid nitrogen for at least 30 min with minimal outside condensation and bubbling.

Included in the FL-1013 Liquid Nitrogen Dewar Assembly, the Dewar flask can be purchased as a spare. The bottom portion, which sits directly in the light path, is constructed of fused silica.



**Note:** If condensation appears on the outside of the Dewar flask, it must be re-evacuated.



**FL-1013 Liquid Nitrogen Dewar Assembly.**

# Sample cells

## J1955 HPLC Flow Cell

With a sample capacity of 20  $\mu\text{L}$ , this non-fluorescing fused silica cell is ideal for on-line monitoring of fluorescent samples. The cell maintains high sensitivity because it has a large aperture for collecting the excitation light to the sample and fluorescence emission from the sample. The flat sides allow maximum throughput while keeping the scattering of the incident radiation to a minimum. The cell fits in a standard cell holder.

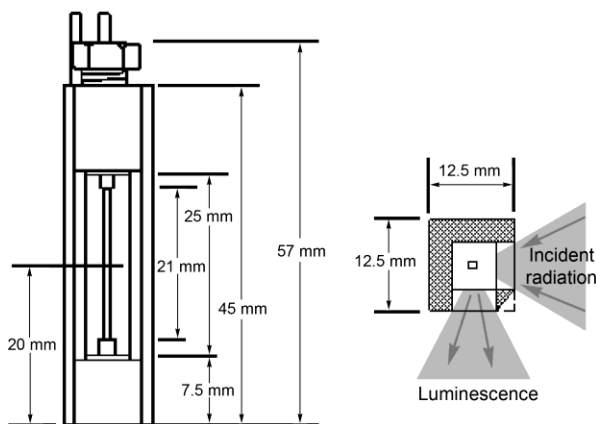

## 1925 Quartz Cuvette

With a 4-mL volume, this cell measures 10 mm  $\times$  10 mm in cross-section, and comes with a Teflon<sup>®</sup> stopper to contain volatile liquids.



## 1920 Sample Cell

This 2-mL to 4-mL non-fluorescing fused silica cell, can accept a magnetic stirrer, has a 10-mm path length, and includes a white Teflon<sup>®</sup> cap that prevents sample evaporation.



# F4-3000 Fiber-Optic Mount and 1950 Fiber-Optic Bundles

Now you can study marine environments, skin and hair, or other large samples *in situ*! For those users who want to examine samples unable to be inserted into the sample compartment, the F4-3000 Fiber Optic Mount (plus fiber-optic bundles) allows remote sensing. The F4-3000 couples to the sample compartment; light is focused from the excitation monochromator onto the fiber-optic bundle, and then directed to the sample. Emission from the sample is directed back through the bundle and into the front-face collection port in the sample compartment. Randomized fiber-optic bundles (#1950) ranging in length from 1 meter to 5 meters are available. Contact your local Sales Representative for details.

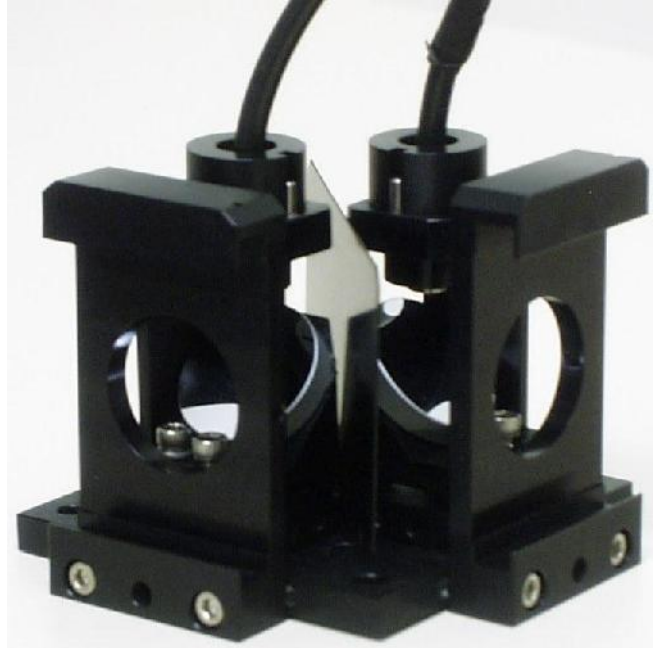

F4-3000 Fiber Optic Mount (above) and 1950 fiber-optic bundle (below).



**Caution:** Intense ultraviolet, visible, or infrared light may be present when the sample compartment is open. Do not aim fiber-optic bundles onto the skin or eyes. Use extreme caution with the fiber-optic probes.

# FL4-1011 Four-Position Thermostatted Cell Holder

The FL4-1011 Four-Position Thermostatted Cell Holder keeps a sample at a constant temperature from  $-20^{\circ}\text{C}$  to  $+80^{\circ}\text{C}$ . The temperature is maintained by an ethylene-glycol-water mixture pumped through from an external circulating temperature bath (not included). The holder also includes a magnetic stirrer, for mixing turbid or viscous samples. Also required is the FM-2003 Sample Compartment Accessory.

## FL4-1011 Four-Position Thermostatted Cell Holder.



**Caution:** Refer to your Material Safety Data Sheet (MSDS) for information on the hazards of an ethylene-glycol-water mixture.

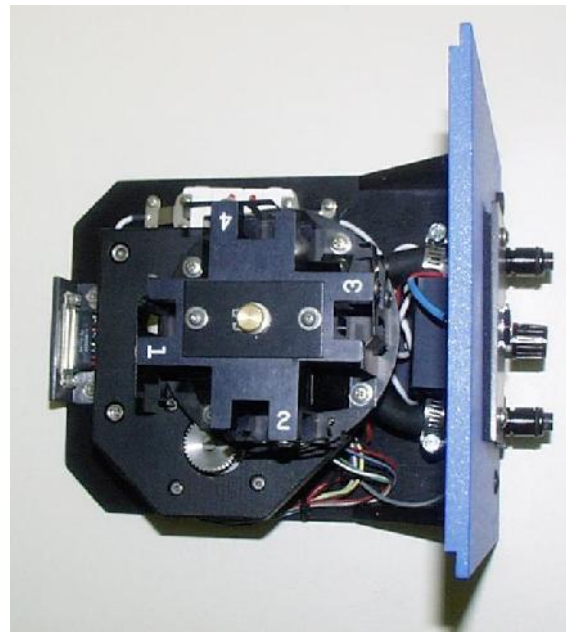

## Installation

- 1 Remove the sample-compartment gap-bed.
- 2 Position the FL4-1011 gap-bed drawer.
- 3 Tighten with four screws.
- 4 Attach the  $\frac{1}{4}$ " tubing to the brass inlets on the bottom of the holder.



**Caution:** Failure to clamp these hoses securely may result in flooding and damage to the optics and electronics of the instrument.

## Use

- 5 Place the sample in a 10 mm × 10 mm cuvette and insert a magnetic stirring bar.

The stirring bar is available from Bel-Art Products, Pequannock, NJ.

- 6 Place a cuvette in each holder.



**Note:** While the four-position model maintains the temperature of all four samples, only one sample is mixed at a time.

- 7 Allow the samples to reach the desired temperature.

- 8 Turn on the magnetic stirrer.

- 9 Select the appropriate mixing speed.

The speed at which the sample should be mixed depends on the viscosity of the sample.



**Note:** Selecting too high a speed may create a vortex, which could affect the reproducibility of the measurement.

- 10 Run your experiment as usual.

- 11 Place the next cuvette in the sample position by lifting up the knob and rotating the holder.

Be sure to press down, to lock the cuvette into the proper position.

# FL4-1012 Dual-Position Thermostatted Cell Holder

The FL4-1012 Dual-Position Thermostatted Cell Holder keeps a sample at a constant temperature from  $-20^{\circ}\text{C}$  to  $+80^{\circ}\text{C}$ . The temperature is maintained by an ethylene-glycol-water mixture pumped through from an external circulating temperature bath (not included). The holder also includes a magnetic stirrer, enabling mixing of turbid or viscous samples. Also required is the FM-2003 Sample Compartment Accessory.

## FL4-1012 Dual-Position Thermostatted Cell Holder.



**Caution:** Refer to your Material Safety Data Sheet (MSDS) for information on the hazards of an ethylene-glycol-water mixture.

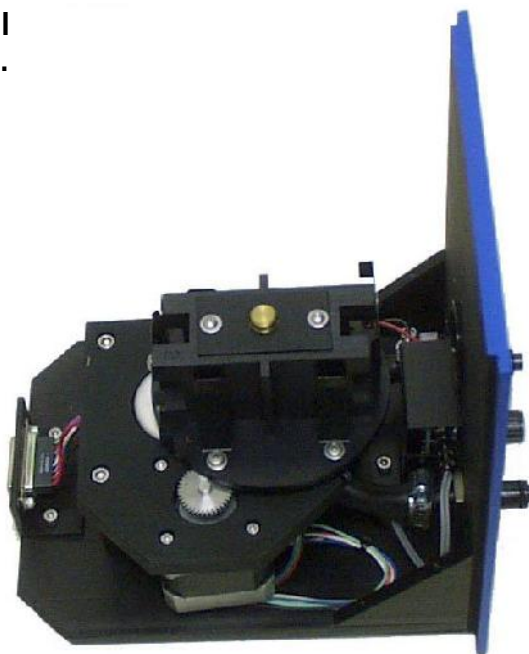

## Installation

- 1 Remove the present holder from the posts.
- 2 Replace with the FL4-1012.
- 3 Tighten the two thumbscrews.
- 4 Attach the  $\frac{1}{4}$ " tubing to the brass inlets on the bottom of the holder.



**Caution:** Failure to clamp these hoses securely may result in flooding and damage to the optics and electronics of the instrument.

## Use

- 1 Place your sample in a 10 mm × 10 mm cuvette and insert a magnetic stirring bar.

The stirring bar is available from Bel-Art Products, Pequannock, NJ

- 2 Place a cuvette in each holder.



**Note:** While the two-position model maintains the temperature of both samples, only one sample is mixed at a time.

- 3 Allow the sample to reach the desired temperature.
- 4 Turn on the magnetic stirrer.
- 5 Select the appropriate speed.

The speed at which the sample should be mixed depends on the viscosity of the sample.



**Note:** Selecting too high a speed may create a vortex, which could affect the reproducibility of the measurement.

- 6 Run your experiment as usual.

# FL4-1027 Single-Position Thermostatted Cell Holder

The FL4-1027 Single-Position Thermostatted Cell Holder keeps a sample at a constant temperature from  $-20^{\circ}\text{C}$  to  $+80^{\circ}\text{C}$ . The temperature is maintained by an ethylene-glycol-water mixture pumped through from an external circulating temperature bath (not included). The holder also includes a magnetic stirrer, enabling mixing of turbid or viscous samples. Also required is the FM-2003 Sample Compartment Accessory.



**Caution:** Refer to your Material Safety Data Sheet (MSDS) for information on the hazards of an ethylene-glycol-water mixture.

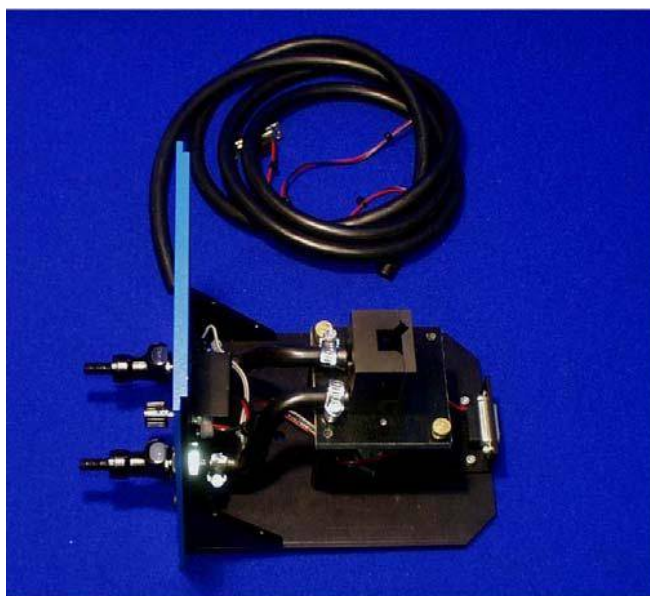

## Installation

- 1 Remove the present holder from the posts.
- 2 Replace with the FL4-1027.
- 3 Tighten the two thumbscrews.
- 4 Attach the  $\frac{1}{4}$ " tubing to the brass inlets on the bottom of the holder.



**Caution:** Failure to clamp these hoses securely may result in flooding and damage to the optics and electronics of the instrument.

## Use

- 1 Place your sample in a 10 mm × 10 mm cuvette and insert a magnetic stirring bar.

The stirring bar is available from Bel-Art Products, Pequannock, NJ

- 2 Place the cuvette in the holder.
- 3 Allow the sample to reach the desired temperature.
- 4 Turn on the magnetic stirrer.
- 5 Select the appropriate speed.

The speed at which the sample should be mixed depends on the viscosity of the sample.



**Note:** *Selecting too high a speed may create a vortex, which could affect the reproducibility of the measurement.*

- 6 Run your experiment as usual.



# J1933 Solid Sample Holder

The J1933 Solid Sample Holder is designed for samples such as thin films, powders, pellets, microscope slides, and fibers. The holder consists of a base with a dial indicating angle of rotation, upon which a bracket, a spring clip, and a sample block rest.

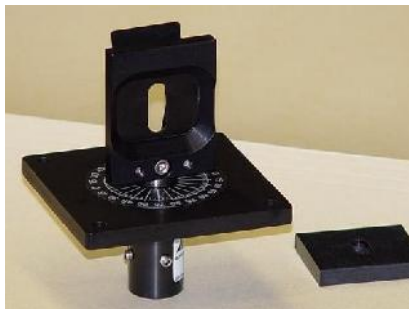

**J1933 Solid Sample Holder  
(with sample block nearby).**

## Installation

- 1 Remove the present holder.
- 2 Position the base on the posts.
- 3 Tighten the two thumbscrews.

For pellets, crystals, creams, gels, powders, and similar materials:

- 1 Fill the well of the block.
- 2 Place a quartz coverslip or Teflon<sup>®</sup> film over the well.



**Caution:** Always read the Material Safety Data Sheet (MSDS) to understand the hazards of handling your sample.

This holds the sample in place when vertically positioned.

- 3 Carefully insert the block between the bracket and spring clip, so that the sample is angled approximately 60° to the excitation light.

This prevents reflections from entering the emission monochromator, and lets the fluorescence emission to be measured with minimal interference from scattered light.



For samples such as thin films, microscope slides, fibers, or other materials:

- 1 Place the material on the block on the side opposite that of the well.



*Caution: Always read the Material Safety Data Sheet (MSDS) to understand the hazards of handling your sample.*

- 2 Carefully insert the block between the bracket and spring clip, so that the sample is angled approximately  $60^\circ$  to the excitation light.

This prevents reflections from entering the emission monochromator, and lets the fluorescence emission to be measured with minimal interference from scattered light.

# 1905-OFR 150-W Xenon Lamp

The 1905-OFR 150-W xenon lamp delivers light from 240 nm to 850 nm for sample excitation. The lamp has an approximate life of 1500 hours, and is ozone-free.



**Caution:** This lamp emits intense light and heat, and contains xenon gas under pressure. Understand all safety precautions before handling or using this xenon-arc lamp.

## FL4-1015 Injector Port

For the study of reaction kinetics, such as  $\text{Ca}^{2+}$  measurements, the FL4-1015 Injector Port is ideal. This accessory allows additions of small volumes via a syringe or pipette to the sample cell without removing the lid of the sample compartment. With the injector in place, a lock-tight seal is achieved, prevented both light and air from reaching the sample.

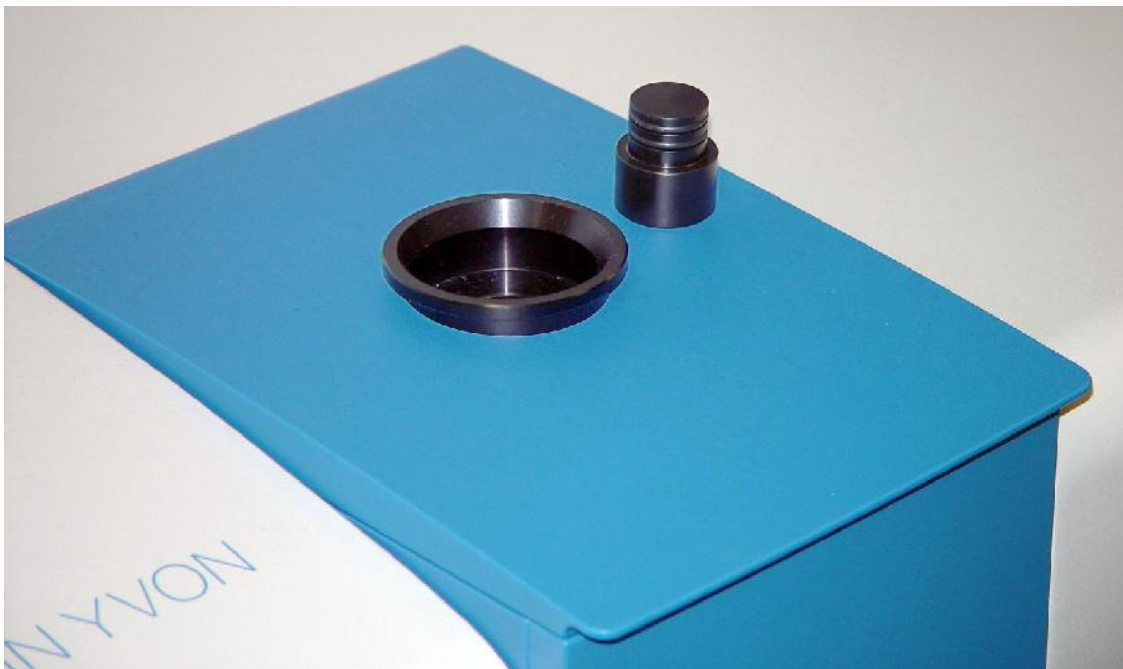

The Injector Port will accommodate most pipettes and syringes, with an injection-hole diameter of 0.125" (3.2 mm). A cap is included to cover the port when not in use.



**Caution:** Always read the Material Safety Data Sheet (MSDS) to understand the hazards of handling your sample.

# F-3030 Temperature Bath

For studies of samples whose properties are temperature-dependent, use the F-3030 Temperature Bath. The controller circulates fluids externally, with tubes leading to the sample chamber. The temperature range is from  $-25^{\circ}\text{C}$  to  $+80^{\circ}\text{C}$ . Sensor and all cables are included with the F-3030. The Temperature Bath is available in a 110-V and 220-V version.



**Warning:** Refer to your Material Safety Data Sheet (MSDS) for information on the hazards of an ethylene-glycol-water mixture.

*This instrument uses high-temperature fluids, which can cause severe burns.*

# 12: Technical Specifications

## Introduction

Each Aqualog<sup>®</sup> system consists of:

- An excitation source
- An excitation monochromator
- A sampling module with reference detector
- An absorption detector
- An emission spectrograph with CCD.

Each system is controlled by an IBM-PC-compatible computer, and may include a printer for hard-copy documentation.

The details and specifications for each component of the Aqualog<sup>®</sup> spectrometer follow.

# Spectrofluorometer system

## Excitation source

<b>Excitation source</b>	150-W xenon, continuous output, ozone-free lamp
<b>Lamp stability</b>	1% per hour
<b>Optics</b>	All-reflective, for focusing at all wavelengths and precise imaging for microsamples.

## Sample compartment

<b>Sample module</b>	The sample module also has a removable gap-bed assembly for sampling accessory replacement.
<b>Reference detector</b>	Calibrated photodiode for excitation reference correction from 200–980 nm.

## Fluorescence

<b>Dispersion</b>	VS140 17 nm mm <sup>-1</sup> Double monochromator 6.7 nm mm <sup>-1</sup>	
<b>Light source</b>	<b>Standard:</b> 150 W ozone-free vertically mounted xenon arc lamp	<b>Extended-UV:</b> 150 W vertically mounted xenon arc lamp
<b>Excitation range</b>	230 nm to upper limit of emission detector	200 nm to upper limit of emission detector
<b>Monochromator</b>	Double-grating excitation monochromator. Aberration-corrected with holographic gratings at $f/2.6$ . All-reflective optics, using 1200-grooves/mm gratings: Bandpass 5 nm Maximum scan speed 500 nm s <sup>-1</sup> Accuracy $\pm 1$ nm Step-size fixed at 0.0625 nm	
<b>Detector</b>	Spectrograph with thermoelectrically-cooled back-illuminated CCD, readout time = 4 ms.	
<b>Detector range</b>	<b>UV-Visible:</b> 250–620 nm	<b>Red-extended:</b> 250–800 nm
<b>Emission grating</b>	405 gr/mm; 250 nm blaze	285 gr/mm; 350 nm blaze
<b>Hardware pixel-binning</b>	0.41, 0.82, 1.64, 3.28 nm/pixel	0.58, 1.16, 2.32, 4.64 nm/pixel
<b>Sensitivity</b>	Double-distilled, de-ionized, ICP-grade water-Raman scan 20 000:1 signal-to-noise ratio at 397 nm, 5-nm bandpass, 30 s integration time, background noise first standard deviation at 450 nm.	
<b>Excitation and emission shutters</b>	Computer-controlled	

<b>Integration time</b>	0.005–65.5 s
<b>Slit width</b>	5 nm bandpass

## Absorbance

<b>Aqualog® scanning range</b>	Scanning range 230–800 nm (optical) Wavelength range 230–1100 nm, with automatic order-filter switching
<b>Aqualog® UV scanning range</b>	Scanning range 200–800 nm (optical) Wavelength range 200–1100 nm, with automatic order-filter switching
<b>Bandpass</b>	5 nm
<b>Slew speed</b>	Up to 500 nm s <sup>-1</sup>
<b>Optical system</b>	Stabilized single-beam, <i>f</i> /3 optics
<b>Detector</b>	Si photodiode
<b>Wavelength accuracy</b>	±1 nm
<b>Photometric accuracy</b>	±0.01 A from 0 to 2 A
<b>Photometric stability</b>	<0.002 A h <sup>-1</sup>
<b>Photometric repeatability</b>	±0.002 A from 0 to 1 A
<b>Stray light in absorbance path</b>	<1% at 230 nm

## Total system

<b>Dimensions (instrument)</b>	24½" wide × 15" high × 17¼" deep 62.2 cm wide × 38.1 cm high × 43.8 cm long Height needed to open sample-compartment lid: 24¼"; 61.6 cm
<b>Dimensions (sample compartment only)</b>	5.5" wide × 7" high × 7" long 14.0 cm wide × 17.8 cm high × 17.8 cm long
<b>Weight</b>	72 lbs (33 kg)
<b>Ambient temperature range</b>	15–30°C 59–86°F
<b>Maximum relative humidity</b>	75%
<b>Power</b>	Universal AC single-phase input power; 85–250 V AC; line frequency 50–60 Hz.
<b>Fuses</b>	Two 5 × 20 mm IEC approved, 4.0 A, 250 V, Time Delay fuses (Cooper Bussman part number GDC-4A or equivalent)

# Minimum host-computer requirements

## Software

Windows® 2000, Windows® XP Pro, Windows® Vista, or Windows® 7 (in 32-bit compatibility mode)

## Hardware

- Supports Windows® 2000, Windows® XP Pro, Windows® Vista, or Windows® 7 (in 32-bit compatibility mode)
- 1 GB RAM
- 1 GB hard-disk space
- One DVD-ROM drive
- One available USB port for USB hardware key
- Video resolution of at least 1024 × 768



**Note:** Additional ports may be required to control accessories such as the temperature bath, etc.

## Software

Aqualog® software for data-acquisition and manipulation through the Windows® environment.



# 13: Glossary

<b>Absorption</b>	Transition, when a photon enters a molecule, from the ground state to the excited singlet state. This process typically occurs in $\sim 10^{-15}$ s.
<b>Absorbance</b>	The extent of light absorption by a substance. Absorbance, $A = -\log T$ , where $T$ is the transmittance of the sample. Absorbance is also synonymous with optical density, OD. Absorbance can be calculated using the Beer-Lambert Law: $A = \epsilon cl = OD = -\log T$ $\epsilon = \text{extinction coefficient (} M^{-1} \text{ cm}^{-1}\text{)}$ $C = \text{sample concentration (} M\text{)}$ $l = \text{path length (cm).}$
<b>A254nm/UVT254nm</b>	Parameter of absorbance at 254 nm indicating presence of organic constituents in the water that may form chlorinated disinfection byproducts.
<b>Acquisition modes (R, S, I channels)</b>	The logical input channels used on the spectrofluorometer to input collected signal from the detectors present on the system. The detectors are assigned as: the reference detector connected to channel R, the emission connected to channel S, and the absorption connected to channel I.
<b>Bandpass</b>	The wavelength range of light passing through the excitation and emission spectrometers. The wider the bandpass, the higher the signal intensity. Bandpass is fixed at 5 nm in the Aqualog <sup>®</sup> .
<b>Bandpass filter</b>	Optical element that selectively transmits a narrow range of optical wavelengths.
<b>Bioluminescence</b>	Emission of light originating from a chemical reaction in a living organism.
<b>Biological Oxygen Demand (BOD)</b>	The amount of oxygen required by aerobic microorganisms to decompose the organic matter (pollution) in a sample of water.
<b>Blank subtraction</b>	The removal of the spectral response of the solvent (and sample container) from the sample's spectral response. To accomplish this, an identical scan is run on the solvent just before running the actual sample. Proper use of a blank can remove solvent luminescence artifacts, scattering events, and any artifacts from the sample cuvette or container.
<b>Blaze wavelength</b>	Wavelength at which a grating is optimized for efficiency. Generally, the gratings are efficient to $\frac{2}{3}$ before the blaze wavelength to twice the blaze wavelength. The excitation and emission gratings are blazed in the UV and visible respectively.

<b>Colored (Chromophoric) Dissolved Organic Matter (CDOM)</b>	Natural organic matter dissolved in a source of water that is colored (light-absorbing) and in many cases also fluorescent.
<b>Chemiluminescence</b>	Emission of light originating from a chemical reaction.
<b>Chemical Oxygen Demand (COD)</b>	Measurement of the amount of oxygen in water consumed for chemical oxidation of pollutants. The amount of oxygen consumed is determined by the pollutant concentration.
<b>Concentration determination</b>	A function of the <b>Single Point</b> type of scan that calculates an unknown sample's concentration. The user runs known samples and enters the concentration in order to calibrate the routine. Then an assay may be completed with the measurements based on concentration.
<b>Corrected emission scan</b>	An emission scan that has been corrected for the wavelength response of the emission monochromator and the signal detector. To obtain a corrected emission scan, an emission spectrum is multiplied by the appropriate emission correction-factor file. A set of emission correction factors is supplied with the instrument and stored under the name <code>mcorrect.spc</code> .
<b>Corrected excitation scan</b>	An excitation scan corrected for the wavelength-characteristics of the xenon lamp, the aging of the xenon lamp, and the gratings in the excitation spectrometer. To obtain a first-order correction of the excitation scan, the emission detector signal is ratioed to the reference signal after the dark current and detector wavelength-response factors are applied for $S_c$ and $R_c$ (i.e., $S_c/R_c$ ). This provides correction for the lamp and emission and excitation-monochromator spectral responses. To obtain a completely correct scan, the excitation correction factors ( <code>xcorrect.spc</code> ) is included.
<b>Correction factors</b>	Compensates for the wavelength-dependent components of the system, like the xenon lamp, gratings, and signal detector. Emission and excitation correction-factor files are included with the software and are titled <code>xcorrect.spc</code> and <code>mcorrect.spc</code> . <code>Xcorrect.spc</code> and <code>mcorrect.spc</code> are applied automatically in the Aqualog <sup>®</sup> software.
<b>Cut-on filter</b>	Optical component that passes light of a higher wavelength.
<b>Cut-off filter</b>	Optical component that passes light of a lower wavelength.
<b>Dark offset</b>	The software correction used to subtract dark counts (or dark signal) on a detector from a spectral acquisition. This feature is implemented automatically in Aqualog <sup>®</sup> software.
<b>Datafile</b>	A file used to store spectral data, constant-wavelength analysis data, or other recorded data. In Aqualog software, the most common datafile is the Origin <sup>®</sup> project ( <code>.opj</code> ). This is the file-type that contains spectra

	acquired from a scan run from the <b>Experiment Setup</b> menu (e.g., Absorbance, 2D emission scan, kinetics scan, single-point, etc.).
<b>Disinfection By-Products (DBPs)</b>	Chemical, organic and inorganic substances that can form during a reaction of a disinfectant (usually chlorine) with natural organic matter dissolved in the water (primarily humic and fulvic acids). Common DBPs are trihalomethanes and haloacetic acids.
<b>Dispersion</b>	The range of wavelengths of light across the field of view of the entrance and exit apertures. Dispersion depends on the focal length of the monochromator, the groove density of the optics, and the $f$ -number (speed) of the monochromator. Dispersion is usually expressed in nanometers of spectral coverage per millimeters of slit width (nm/mm).
<b>Emission scan</b>	Shows the spectral distribution of light emitted by the sample. During an emission scan, the excitation monochromator remains at a fixed wavelength while the emission detector scans a selected region.
<b>Energy transfer</b>	The transfer of the excited energy from a donor to an acceptor. The transfer occurs without the appearance of a photon and is primarily a result of dipole-dipole interactions between the donor and acceptor.
<b>Excitation/emission matrix (EEM)</b>	A three-dimensional plot showing the total luminescence from a sample across all useful wavelengths. Total luminescence spectroscopy is devoted to measurements of these EEMs for various materials. See also: <b>Total Luminescence Spectroscopy</b>
<b>Excitation monochromator</b>	The monochromator, located between the xenon lamp and the sample compartment, used to isolate discrete wavelength components of the excitation beam. This beam is directed to the sample, during which the excitation monochromator may be used to scan the excitation spectrum from a sample. The excitation monochromator on the Aqualog <sup>®</sup> is a 0.10-m double monochromator with slit apertures at the entrance, intermediate and exit. An excitation shutter is located directly after the excitation exit slit to protect the sample from photobleaching between measurements. The reference detector automatically looks at a fraction of the light exiting the excitation monochromator to correct for the lamp for all Aqualog <sup>®</sup> experiments.
<b>Excitation scan</b>	Shows the spectral distribution of light absorbed by the sample corresponding to fluorescent components of the sample. To acquire an excitation scan, the excitation monochromator scans a selected spectral region while the emission detection remains at a fixed wavelength region. In the Aqualog <sup>®</sup> , 2D excitation spectral profiles must be extracted from the EEM data set using the 2D profile tool.
<b>Excited state (<math>S_1</math>)</b>	The energy level to which an electron in the ground level of a molecule is raised after the absorption of a photon of a particular wavelength. Subsequently, fluorescence occurs, if the molecule returns to the ground state via a radiative transfer from the $S_1$ state to the ground state.

<b>Experiment file</b>	A file that contains specific information on the experimental setup for an acquisition defined in <b>Experiment Setup</b> . This file is saved with a default *.xml extension. In addition to basic scan parameters, this file saves system defaults and some accessory settings for the acquisition. Each acquisition type in the <b>Aqualog Experiment Menu</b> has its own default experiment file (e.g., <code>DefaultEm1.xml</code> is the default emission-scan definition). Use experiment files to archive scan settings for acquisitions that are performed routinely.
<b>Extrinsic fluorescence</b>	Inherent fluorescence of probes used to study non-fluorescent molecules.
<b>Filter</b>	An optical element that is used to select certain wavelengths of light. Types of filters include high-pass, low-pass, bandpass, and neutral density.
<b>Fluorescence</b>	The emission of light during the transition of electrons from the excited singlet state to the ground state from molecules originally excited by the absorption of light. Fluorescence typically occurs within $\sim 10^{-9}$ seconds.
<b>Fluorescence lifetime (<math>\tau</math>)</b>	The average length of time that a molecule remains in the excited state before returning to the ground state.
<b>Fluorophore (fluorescent probe)</b>	A molecule or compound that has a known fluorescence response. These probes have various sensitive areas depending on the peak excitation and emission wavelengths and their fluorescence lifetimes. Fluorophores are used to provide information on concentration, size, shape, and binding, in a particular medium. Good fluorophores are stable over wide pH and temperature ranges as well as resistance to photobleaching.
<b>Front-face detection</b>	A mode of detection in which fluorescence is collected off the front surface of the sample. Front-face detection usually is selected for samples such as powders, thin films, pellets, cells on a cover-slip, and solids.
<b>Fulvic Acid</b>	A yellow (Latin <i>fulvus</i> = yellow) to yellow-brown humic substance soluble in water at all pH values. Fulvic acid is less aromatic (fewer benzene rings) and has a more acidic character than humic acid.
<b>Grating</b>	Optical element in the monochromator, consisting of finely scribed grooves that disperse polychromatic light into its component spectra.
<b>Ground state (<math>S_0</math>)</b>	The lowest energy level in a molecule. For fluorescence to occur, a molecule absorbs a photon of light, thereby exciting it to the $S_1$ level. A fluorescence emission occurs during a transition from an excited state $S_1$ to the ground state $S_0$ .
<b>High-pass filter</b>	Optical component that passes light of a higher wavelength.
<b>Humic Acid</b>	Any of the mixture of complex macromolecules having polymeric phe-

	nolic structures and extractable from soils (humus) and peat. Soluble in water only above pH 2. Produced by the oxidative degradation of lignin, and has the ability to chelate metals, especially iron.
<b>Increment</b>	The spacing between adjacent measurement points in an acquisition. Typically, increments take the form of wavelength (nm) or time (s or ms).
<b>Inner-filter effect</b>	The absorption of the excitation beam or fluorescence emission from a concentrated sample by components in the sample. Note there are Primary and Secondary inner-filter-effects (IFE). IFEs reduce the signal intensity from the sample creating artifacts in the spectra. For this reason, we recommend using concentrations of <0.05 OD in a 1-cm-pathlength cell. The Aqualog IFE tool can automatically correct most samples for IFE. IFE correction requires the sample concentration be in the linear Beer-Lambert region.
<b>Integration time</b>	The amount of time that each data point is collected from the detector(s), specified in seconds. Longer integration times can help improve the signal-to-noise ratio for a measurement, while shorter integration times reduce the amount of time required for a scan and prevent saturation of the fluorescence detector. Choose integration times to optimize the signal-to-noise ratio.
<b>Internal conversion</b>	Electronic transitions within an excited molecule that do not result in emission. Also called a “non-radiative transition”, this usually involves changes in vibrational levels.
<b>Intersystem crossing</b>	The electronic transition from the excited singlet state to the excited triplet state before returning to the ground state. This transition involves a change of spin that is quantum-mechanically forbidden, giving a much longer timescale than fluorescence. This transition causes phosphorescence on the timescale of microseconds to seconds.
<b>Intrinsic fluorescence</b>	The natural fluorescent properties of molecules.
<b>Jablonski (energy) diagram</b>	A diagram that illustrates various energy levels and electronic transitions available in a particular molecule. Possible paths for fluorescence, phosphorescence, and non-radiative transfers are shown on this diagram, along with the various vibrational sub-levels available around each energy level.
<b>Laser</b>	A monochromatic light source that provides high excitation intensity. The word “laser” is an acronym: <b>L</b> ight <b>a</b> mplification by <b>s</b> timulated <b>e</b> mission of <b>r</b> adiation.
<b>Linearity</b>	Signal response; the desired response from a light detector is a linear relationship. For example, when detector response is linear, if the light intensity doubles, the detected signal also doubles. See <b>Spectral Calibration</b> .

<b>Low-pass filter</b>	Optical component that passes light of a lower wavelength.
<b>Luminescence</b>	The emission of light from matter excited from a variety of processes, resulting in an electronic transition within the molecule to a lower energy state. See also: <b>Bioluminescence</b> , <b>Chemiluminescence</b> , <b>Fluorescence</b> .
<b>MCD shutter</b>	Multi-channel device shutter.
<b>Mercury lamp</b>	Light source that emits discrete, narrow lines as opposed to a continuum. A mercury lamp can be used to check the monochromator's calibration.
<b>Mirror-image rule</b>	When the emission profile appears to be the mirror image of the absorption spectrum.
<b>Molar extinction coefficient (<math>\epsilon</math>)</b>	The absorptivity of a particular substance, in $M^{-1} \text{ cm}^{-1}$ .
<b>Monochromator</b>	The component in a spectrofluorometer that is scanned to provide the excitation spectra. Monochromators are chosen for stray-light rejection, resolution, and throughput.
<b>Neutral-density filter</b>	An optical element that absorbs a significant fraction of the incident light. These filters usually are characterized by their optical density, on a logarithmic scale. For example, a filter with $OD = 1$ transmits 10% of the incident light. Ideally, these filters absorb all wavelengths equally. See also <b>Absorbance</b> .
<b>Natural Organic Matter (NOM)</b>	Organic matter originating from natural sources (primarily decomposed plant and animal material that leaches from soil), that is dissolved in a water source.
<b>Optical density</b>	A synonym of <i>absorbance</i> . See <b>Absorbance</b> .
<b>Optical-density effects (Inner-filter effect)</b>	Fluorescence intensities are proportional to the concentration over a limited range of optical densities. High optical densities can distort the emission spectra as well as the apparent intensities. See also <b>Inner-filter effect</b> .
<b>Parallel Factor Analysis (PARAFAC)</b>	A multi-way canonical decomposition-analysis method.
<b>Phosphorescence</b>	The emission of light or other electromagnetic radiation during the transition of electrons from the triplet state to the ground state. Phosphorescence is generally red-shifted relative to fluorescence and occurs within $\sim 10^{-6}$ to $\sim 1$ second. To enhance phosphorescence, samples often are frozen at liquid-nitrogen temperature (77 K).

<b>Photobleaching</b>	The reduction in fluorescence from a photosensitive sample overly exposed to excitation light. Not all samples photobleach, but if so, take care to keep the sample out of room light. The Aqualog <sup>®</sup> scans rapidly and from low energy to high energy to minimize photobleaching.
<b>Principle Component Analysis (PCA)</b>	Uses an orthogonal transformation to convert a set of observations of possibly correlated variables into a set of values of uncorrelated variables called “principle components.”
<b>Quantum yield (Fluorescence quantum yield)</b>	The efficiency of the absorption of a photon to be emitted (fluoresced). Quantum yields typically are expressed as percents. The fluorescence quantum yield is the percentage of photons absorbed that actually leads to fluorescence. This number is reduced by scattering, quenching, internal conversion, and non-radiative effects, along with several other specialized processes.
<b>Quenching</b>	Reduction in the fluorescence intensity of a sample by a variety of chemical or environmental influences. Quenching may be static, dynamic, or collisional in nature.
<b>Quinine Sulfate Unit (QSU)</b>	The fluorescence intensity of 1 part per million (1.26 $\mu M$ ) quinine sulfate dissolved in 0.1 M HClO <sub>4</sub> , when excited at 347.5 nm and its emission measured at 450 nm for a prescribed set of bandpass and integration time conditions.
<b>Raman scattering</b>	Scattering caused by vibrational and rotational transitions of molecular atomic bonds. Raman bands generally appear red-shifted relative to the incident electromagnetic radiation. The primary characteristic of Raman scatter is that the difference in energy between the Raman peak and the incident radiation is constant in energy units ( $\text{cm}^{-1}$ ) for a given molecular bond’s vibrational mode.
<b>Rayleigh scattering</b>	Light scattering from particles whose dimensions are much smaller than the wavelength of incident light. Rayleigh-scattered light is of the same energy as the incident light. The scattered radiation’s intensity is inversely proportional to the 4 <sup>th</sup> power of the wavelength of incident radiation.
<b>Real Time Control</b>	The Aqualog <sup>®</sup> software application that gives the user full control of the system in real-time, in order to optimize the system setup for a particular measurement. Use <b>Real Time Control</b> to find the optimal slit widths for sample measurements, or to check that the excitation beam is striking the sample properly.
<b>Reference detector</b>	The detector used to monitor the output of the xenon lamp. A silicon photodiode with enhanced-UV response is used for the Aqualog, and is connected to input channel R. In the Aqualog <sup>®</sup> , both the absorbance and fluorescence emission detection-paths are automatically corrected by

dividing by the reference-detector signal.

<b>Resolution</b>	The ability to separate two closely spaced peaks. Resolution can be improved by decreasing the bandpass and the increment (step size).
<b>Right-angle detection</b>	Collection of fluorescence at 90° to the incident radiation. Right-angle detection typically is selected for dilute and clear solutions.
<b>Sample changer (automated)</b>	An automated accessory that automatically positions up to four cuvettes held in the sample compartment. Use this accessory to run up to four samples at one time for a small assay, or to run blanks with the samples simultaneously. Automated sample changers are thermostatted and possess magnetic stirrers.
<b>Saturation</b>	The effect of having too much signal incident on a particular detector. Saturated detectors give erroneous results, and do not show any response for small changes in signal. The Aqualog® CCD saturation (16 bits resolution) is at 65 536 counts per integration-time interval.
<b>Scatter</b>	A combination of Raman, Rayleigh, and Rayleigh-Tyndall scattering, which can distort fluorescence spectra with respect to intensities and wavelengths.
<b>Signal channel</b>	See: <b>Acquisition modes</b> .
<b>Signal-to-noise ratio (S/N)</b>	The measurement of the signal observed divided by the noise component seen in that signal. Generally, the better the S/N is, the better the measurement is.
<b>Single Point</b>	The Aqualog® scan-type designed for performing single-point absorbance only measurements at discrete wavelength pairs. The data are acquired as single points at a user-defined set of excitation-emission wavelength pairs for a user-defined number of samples. These data are displayed in either spreadsheet format, or in a plot.
<b>Singlet state</b>	The spin-paired ground or excited state. The process of absorption generally produces the first excited singlet state, which takes time to fluoresce, and may undergo intersystem crossing to form a triplet state.
<b>Spectral calibration</b>	The accuracy of a monochromator with respect to its wavelength alignment. This is a measure of the monochromator being at the correct wavelength when it is set there. Monochromators are traditionally calibrated using line-spectra sources, such as mercury lamps. The Aqualog® automatically checks its calibration via validation tests.
<b>Spectral correction</b>	The removal of the wavelength sensitivity of detectors, optics, sources, and backgrounds from the spectrum taken on a sample. All corrections are applied automatically with Aqualog® software. When spectral correction has been properly performed, the true theoretical spectra from a sample should be all that remains. Spectral correction is accomplished



with a variety of options on HORIBA Scientific spectrofluorometers. Excitation and emission correction-factor files are provided to remove the wavelength-sensitivity of detectors and their optics. The reference detector is present to remove the lamp and excitation optics' response. Blank-subtraction and dark-offset are used to remove background levels and responses.

**Spectral response**

All detectors have a higher sensitivity to some wavelengths than to others. The spectral response of a detector is often expressed graphically in a plot of responsivity versus wavelength.

**Spectrofluorometer**

An analytical instrument used to measure the fluorescence properties of a molecule or substance. The device consists of at least two monochromators, a source, a sample compartment and detection electronics. The instruments may be scanned on the excitation, emission or both to provide insight on the characteristics of the sample being studied. Newer spectrofluorometers provide many more automated options, including polarization, temperature, titer plates, pressure, and many more. Today, these instruments are computer-controlled, allowing easy control of assays and complex experiments.

**Stokes shift**

Generally, the energy-difference between the absorption peak of lowest energy and the fluorescence peak of maximum energy.

**Specific Ultraviolet Absorbance (SUVA)**

The ratio of the A<sub>254</sub> nm/cm to the total concentration of dissolved organic carbon in a filtered sample.

$$\text{SUVA} \left( \text{in } \frac{\text{L}}{\text{mg} \cdot \text{M}} \right) = \frac{\text{A}_{254}/\text{cm}}{\text{mg DOC/L}} \times 100 \text{ cm/M}$$

SUVA is used to predict the potential for the formation of disinfection byproducts. It is also used to determine compliance with the disinfection byproducts rule-requirements for removing NOM.

**Technical spectrum**

A spectrum acquired on research instrumentation with instrumental bias remaining in the measurement. This spectrum must undergo proper spectral correction in order to match the theoretical spectrum. HORIBA Scientific spectrofluorometers offer various methods for such correction, including spectral correction, dark offset, blank subtraction, and others.

**Temperature scan**

A Kinetics scan-definition that consists of a particular scan made across a user-defined temperature range. This scan may be used to monitor a sample's temperature response, or, more specifically, to perform a melting curve for a sample. Temperature scans require an automated bath compatible with Aqualog<sup>®</sup> software to be attached to the spectrofluorometer system along with a thermostatable sample mount.

**Throughput**

The amount of light that passes through the spectrofluorometer for a

particular measurement. The throughput usually is measured as the counts per second measured on the water Raman band at 350-nm excitation with 5-nm bandpass. As bandpass increases, so does the throughput. Like bandpass, throughput has an inverse relationship with resolution. When the throughput is increased, the resolution decreases.

<b>Time-based scan</b>	Scan type in which the sample signal is monitored as a function of time, while both the excitation and the emission spectrometers remain at fixed wavelengths. Time-based data are used to monitor enzyme kinetics, dual-wavelength measurements, and determine reaction-rate constants.
<b>Total luminescence spectroscopy (TLS)</b>	Spectroscopy devoted to monitoring changes to the entire excitation/emission matrix of luminescence on a sample. This discipline is best applied to fast kinetics measurements of samples during reactions, temperature curves, or changes in other parameters.
<b>Transmission</b>	Light that passes through a sample without being absorbed, scattered, or reflected. Transmission is usually measured as a percentage of the incident light at a certain wavelength.
<b>Triplet state (<math>T_1</math>)</b>	The spin-paired ground or excited state formed from the excited singlet state, in which electrons are unpaired. The triplet state gives rise to phosphorescence.
<b>Tyndall scattering</b>	Scatter that occurs from small particles in colloidal suspensions.
<b>Vibrational states</b>	Sublevels within an electronic energy level resulting from various types of motion of the atoms in a molecule. Transition between these states at a particular energy level does not involve a large change in energy, and typically is a non-radiative transition. In larger electronic transitions such as fluorescence, a molecule drops from the lowest vibrational level of the excited state to the highest vibrational level of the ground state. This emission is termed the Stokes shift between the $S_1$ and ground states.
<b>Xenon lamp</b>	Lamp that produces a continuum of light from the ultraviolet to the near-infrared for sample excitation.
<b>Xenon-lamp scan</b>	A profile of the lamp output as a function of wavelength. The lamp scan is acquired using the reference detector while scanning the excitation spectrometer. The maximum xenon-lamp peak at 467 nm can be used to determine proper calibration of the excitation spectrometer.

# 14: Bibliography

- P.M. Bayley and R.E. Dale, *Spectroscopy and the Dynamics of Molecular Biological Systems*, Academic Press, London, 1985.
- R.S. Becker, *Theory and Interpretation of Fluorescence and Phosphorescence*, Wiley-Interscience, New York, 1969.
- I.B. Berlman, *Handbook of Fluorescence Spectra in Aromatic Molecules*, 2nd ed., Vols. I & II, Academic Press, New York, 1971.
- C.R. Cantor and P.R. Schimmel, *Biophysical Chemistry: Techniques for the Study of Biological Structure and Function*, Vols. 1 & 2, W.H. Freeman, New York, 1980 & 1990.
- M. Chalfie and S. Kain, *Green Fluorescent Protein: Properties, Applications, and Protocols (Methods of Biochemical Analysis)*, 2<sup>nd</sup> ed., Jossey-Bass, New York, 2005.
- R.F. Chen, *et al.*, *Biochemical Fluorescence: Concepts*, Vol. I & II, 1964 & 1970.
- R.M. Cory, and D. M. McKnight, "Fluorescence spectroscopy reveals ubiquitous presence of oxidized and reduced quinones in dissolved organic matter," *Environ. Sci. Technol.* **39**, 8142–8149 (2005).
- \_\_\_\_\_, *et al.*, "Effect of instrument-specific response on the analysis of fulvic acid fluorescence spectra," *Limnol. Oceanogr.: Methods* **8**, 67–78 (2010).
- J.N. Demas, *Excited State Lifetime Measurements*, Academic Press, New York, 1983.
- P.C. DeRose and U. Resch-Genger, "Recommendations for Fluorescence Instrument Qualification: The New ASTM Standard Guide," *Anal. Chem.*, **82**, 2129–2133 (2010).
- \_\_\_\_\_, *et al.*, "Qualification of a fluorescence spectrometer for measuring true fluorescence spectra," *Rev. Sci. Instr.* **78**, 033107 (2007).
- E. Gratton, D.M. Jameson, and R.D. Hall, "Multifrequency Phase and Modulation Fluorometry," *Ann. Rev. Biophys. Bioeng.* **13**, 105–124 (1984).
- Q. Gu and J.E. Kenny, "Improvement of Inner Filter Effect Correction Based on Determination of Effective Geometric Parameters Using a Conventional Fluorimeter," *Anal. Chem.* **81**, 420–426 (2009).
- G.G. Guilbault, ed., *Fluorescence—Theory, Instrumentation and Practice*, Marcel Dekker, New York, 1967.
- \_\_\_\_\_, *Practical Fluorescence: Theory, Methods and Techniques*, 2<sup>nd</sup> ed., Marcel Dekker, 1990.
- \_\_\_\_\_, "Molecular Fluorescence Spectroscopy," *Anal. Chem.* **8**, 71–205 (1977).
- D.M. Hercules, ed., *Fluorescence and Phosphorescence Analysis*, Wiley-Interscience, New York, 1966.
- Henderson, *et al.*, "Fluorescence as a potential monitoring tool for recycled water systems: A review," *Water Research* **43**, 863 (2010).
- Holbrook, *et al.*, "Excitation–emission matrix fluorescence spectroscopy for natural organic matter characterization: A quantitative evaluation of calibration and spectral correction procedures," *Appl. Spectroscopy* **60**(7), 791(2006).

- Hudson, *et al.*, "Fluorescence analysis of dissolved organic matter in natural, waste and polluted waters—A," *Review. River. Res. Applic.* **23**, 631–649 (2007).
- J.D. Ingle and S.R. Couch, *Spectrochemical Analysis*, Prentice-Hall, Englewood Cliffs, NJ, 1988.
- F.H. Johnson, *The Luminescence of Biological Systems*, Amer. Assoc. Adv. Sci., Washington, D.C., 1955.
- S.V. Konev, *Fluorescence and Phosphorescence of Proteins and Nucleic Acids*, Plenum Press, New York, 1967.
- M.A. Konstantinova-Schlezing, ed. *Fluorometric Analysis*, Davis Publishing Co., New York, 1965.
- J. R. Lakowicz, *Principles of Fluorescence Spectroscopy*, 3<sup>rd</sup> ed., Springer, New York, 2006.
- \_\_\_\_\_, ed., *Topics in Fluorescence Spectroscopy*, Vols. 1–5, Plenum Press, New York, 1991–1998.
- \_\_\_\_\_, Badri P. Melinal, Enrico Gratton, "Recent Developments in Frequency-Domain Fluorometry," *Anal. Instr.*, **14** (314), 193–223 (1985).
- \_\_\_\_\_, S. Soper, and R. Thompson, *Advances in Fluorescence Sensing Technology IV*, SPIE Proc. Series, Vol. 3602 (1999).
- T. Larsson, M. Wedborg, and D. Turner, "Correction of inner-filter effect in fluorescence excitation-emission matrix spectrometry using Raman scatter," *Anal. Chim. Acta*, **583**, 357–363 (2007).
- B. C. MacDonald, S. J. Lvin, and H. Patterson, "Correction of fluorescence inner filter effects and the partitioning of pyrene to dissolved organic carbon," *Anal. Chim. Acta*, **338**, 155 (1997).
- W.T. Mason, ed., *Fluorescent and Luminescent Probes for Biological Activity: A Practical Guide to Technology for Quantitative Real-Time Analysis*, 2<sup>nd</sup> ed., Academic Press–Harcourt Brace & Co., 1999.
- W.H. Melhuish and M. Zander, "Nomenclature, Symbols, Units and Their Usage in Spectrochemical Analysis VI: Molecular Luminescence Spectroscopy," *Pure App. Chem.*, **53**, 1953 (1981).
- J.N. Miller, ed., *Standardization & Fluorescence Spectrometry: Techniques in Visible and Ultraviolet Spectrometry*, Vol. 2, Chapman and Hall, 1981.
- Murphy, *et al.*, "The measurement of dissolved organic matter fluorescence in aquatic environments: An interlaboratory comparison," *Environ. Sci. Technol.* (in press) (2010).
- W.G. Richards and P.R. Scott, *Structure and Spectra of Molecules*, John Wiley & Sons, 1985.
- A. Schillen, *et al.*, *Luminescence of Organic Substances*, Hellwege Verlag, Berlin, 1967.
- S.G. Schulman, ed., *Molecular Luminescence Spectroscopy: Methods and Applications*, Vols. 1–3, Wiley-Interscience, New York, 1985–1993.
- A. Sharma and S. Schulman, *Introduction to Fluorescence Spectroscopy*, Wiley Interscience, New York, 1999.

- D.A. Skoog, F.J. Holler, and T.A. Nieman, *Principles of Instrumental Analysis*, 5<sup>th</sup> ed., Brooks Cole, New York, 1998.
- C. A. Stedmon, S. Markager, and R. Bro, "Tracing dissolved organic matter in aquatic environments using a new approach to fluorescence spectroscopy," *Mar. Chem.* **82**, 239–254 (2003).
- \_\_\_\_\_, "Characterizing dissolved organic matter fluorescence with parallel factor analysis: a tutorial," *Limnol. Oceanogr.: Methods* **6**, 572–579 (2008).
- N.J. Turro, V. Ramamurthy, and J.C. Scaiano, *Modern Molecular Photochemistry of Organic Molecules*, University Science Books, New York, 2006.
- K. Van Dyke, *Bioluminescence and Chemiluminescence: Instruments and Applications*, Vol. 1, CRC Press, Boca Raton, FL, 1985.
- T. Vo-Dinh, *Room Temperature Phosphorimetry for Chemical Analysis*, Wiley-Interscience, New York, 1984.
- I.M. Warner and L.B. McGown, ed., *Advances in Multidimensional Luminescence*, Vols. 1 & 2, JAI Press, Greenwich, CT, 1991–1993.
- E.L. Wehry, ed., *Modern Fluorescence Spectroscopy*, Vol. 1–4, Plenum Press, New York, 1975–1981.
- C.E. White and R.J. Argauer, *Fluorescence Analysis: A Practical Approach*, Marcel Dekker, New York, 1970.
- J.D. Winefordner, S.G. Schulman, and T.C. O'Haver, *Luminescence Spectrometry in Analytical Chemistry*, Wiley-Interscience, New York, 1972.

In addition, the following journals may prove useful:

*Analytical Chemistry*  
*Biophysics and Biochemistry*  
*Journal of Fluorescence*  
*Nanotechnology Letters*



# 15 : CE Compliance Information

## Declaration of Conformity

**Manufacturer:** HORIBA Instruments Incorporated

**Address:** 3880 Park Avenue  
Edison, NJ 08820  
USA

**Product Name:** Aqualog

**Model #:** Aqualog  
Aqualog-UV

Conforms to the following Standards:

**Safety:** EN 61010-1: 2001

**EMC:** EN 61326-1: 2006 (Emissions & Immunity)

## Supplementary Information

The product herewith complies with the requirements of the Low Voltage Directive 2006/95/EC and the EMC Directive 2004/108/EC.

The CE marking has been affixed on the device according to Article 8 of the EMC Directive 2004/108/EC.

The technical file and documentation are on file with HORIBA Instruments Incorporated.



---

Sal Atzeni  
Vice-President, Retail Engineering, and CTO

HORIBA Scientific  
Edison, NJ 08820  
USA  
August 18, 2011

## **Applicable CE Compliance Tests and Standards**

<b>Test</b>	<b>Standards</b>
Emissions, Radiated/Conducted	EN 61326-1: 2006
Radiated Immunity	EN 61326-1: 2006
Conducted Immunity	EN 61326-1: 2006
Electrical Fast Transients	EN 61326-1: 2006
Electrostatic Discharge	EN 61326-1: 2006
Voltage Interruptions	EN 61326-1: 2006
Surge Immunity	EN 61326-1: 2006
Magnetic Field Immunity	EN 61326-1: 2006
Harmonics	EN 61000-3-2: 2006
Flicker	EN 61000-3-3: 2008
Safety	EN 61010-1: 2001



# Chapter 16 : Index

Key to the entries:

Times New Roman font.....	subject or keyword
Arial font.....	command, menu choice, or data-entry field
<b>Arial Condensed Bold font</b> .....	dialog box
Courier New font.....	file name or extension

---

▶ button .....	6-12, 6-28
----------------	------------

**1**

15-pin connector .....	3-5, 10-2
1905-OFR .....	11-14
1920 .....	11-4
1925 .....	11-4
1950 .....	11-5
1955 .....	11-4
1. Load Calibration data label .....	8-4

**2**

2. Load Conc. Data (opt.) button .....	8-26
--	------

**3**

351697 .....	2-5
3D button .....	6-9, 6-25
3D data.....	5-31

**5**

53057 .....	2-5
-------------	-----

**9**

98015 .....	2-5
-------------	-----

98020 .....	2-5
-------------	-----

**A**

<b>About Aqualog</b> window .....	7-4-5
About Aqualog... ..	7-4
Abs and Trans Graphs tab.....	6-20
Abs Photometric Accuracy (Starna RM-06HLKI).....	4-7
Abs Spectra Graphs tab .....	6-12, 6-28
Abs/Ex Wavelength Accuracy .....	4-4
Absorbance.....	6-2
absorbance scan .....	5-2
Absorbance spectra .....	6-1-2
Accumulations field.....	9-7
Add button.....	6-22
Add --> button.....	8-5
<b>Add Sample Types</b> window .....	6-22
Advanced button.....	7-8
Alconox® .....	9-1
All Programs .....	10-13
Allen key ... ..	2-5, 10-1, 10-3, 10-5, 10-7, 10-9, 10-18-19
<b>Analysis – CLS (No Model)</b> window .....	8-23
<b>Analysis – PARAFAC (No Model)</b> window .....	8-2
<b>Analysis – PCA (No Model)</b> window .....	8-18
Analysis Tools area.....	8-2, 8-23
Apply button.....	10-17
<b>Aqualog Configuration</b> window.....	10-13-14
AquaLog Experiment Options area.....	5-4
<b>Aqualog Experiment Setup</b> window .....	2-11, 5-3, 5-6, 5-23, 5-37, 6-2, 6-6, 6-9, 6-18, 6-21, 6-26
<b>AquaLog Experiment Type</b> window.....	2-10, 5-3, 6-2, 6-6, 6-9, 6-18, 6-25, 10-15
Aqualog icon .....	2-9, 4-2
Aqualog IFE button.....	5-9, 6-13, 6-29
<b>AquaLog Main Experiment Menu</b> .....	2-10, 5-2, 5-3, 6-2, 6-6, 6-9, 6-18, 6-21, 6-25, 10-14
<b>Aqualog</b> main window .....	2-9, 4-4, 4-7, 4-11, 4-15, 4-18, 4-21, 7-4
<b>Aqualog Sample Q Complete</b> window .....	5-32
<b>Aqualog Sample Q Resume</b> window .....	5-32
<b>Aqualog Sample Q</b> window .....	5-29

Aqualog<sup>®</sup> software 0-1, 2-5, 2-7, 2-9, 2-11, 3-4, 3-6-7, 4-3-4, 5-1, 7-1, 7-3-5, 9-6-8, 10-14, 12-4  
 Aqualog<sup>®</sup>-UV..... 10-1, 10-21  
 Aqualog UV filter kit..... 10-21  
 AquaLog V... tab..... 10-17  
 Aqualog Validation Tests 4-4, 4-7, 4-12, 4-15, 4-18, 4-21  
**Aqualog** window ..... 4-2, 5-16  
 ASCII format ..... 5-26  
 Auto Run Previous Experiment button. 5-8  
 Auxiliary column ..... 8-10  
 Available Methods list..... 8-5

---

## B

bandpass ..... 3-4, 9-8-9, 12-2, 12-3  
 batch job..... 5-14-15  
 batch-processing ..... 5-22  
 Beer-Lambert law ..... 1-3-4, 9-11  
 Between Each Experiment field ..... 5-34  
 Bin field ..... 10-17  
 biological samples..... 9-3  
 blank.....6-3, 6-7, 6-10  
 Blank..... 6-22  
 blank files..... 5-2  
 Blank Group Start # ..... 5-25  
 \*.blank..... 5-2  
 blazing..... 3-4  
 Browse button ..... 5-5  
 Browse for experiment files to >> Add  
 button ..... 5-14  
**Browse for Folder** window..... 5-25  
 Browse... button ..... 5-25  
 B(X) cells ..... 4-9

---

## C

cable ..2-5-6, 2-9, 7-2-3, 10-2, 10-12, 10-19-20, 11-16  
 Cancel button...4-6, 4-9, 4-14, 4-17, 4-20, 4-23, 5-18, 5-38, 6-5, 6-20, 6-23, 10-19  
 caution notice ..... 0-5  
 CCD detector 3-2, 3-5-6, 4-11, 7-1-2, 9-4-5, 12-1-2  
 CCD Gain .....

CCD Gain drop-down menu 5-17, 5-37, 6-7, 6-10, 6-19, 6-26,  
 CCD saturation ..... 9-9-10  
 CCD shot noise..... 9-9  
 CDOM..... 1-1-3, 1-5-6, 9-9-11  
 CE compliance.....0-12  
 CE Compliance Tests and Standards..... 14-3  
 Certified Value..... 4-9  
 charcoal filters ..... 10-1, 10-21  
 Classical Least-Squares Analysis ..... 8-1  
 classical least-squares fitting ..... 8-23  
 CLS..... 8-1  
 CLS – Classical Least Squares sub-  
 header ..... 8-23  
 Collect..... 4-4, 4-7, 4-11, 4-15, 4-18, 4-21  
 colored dissolved organic matter..... 1-1  
 Comments field ..... 5-14  
 confidence intervals..... 8-10  
 constraints..... 8-15  
 Constraints area ..... 8-15  
 Continue button.....5-27, 5-35-36  
 Continuous checkbox..... 10-17  
 contour..... 8-13  
 Core Consistency thumbnail ..... 8-10  
 correction-factor files ..... 3-6  
 coverslips..... 9-2  
 Create button..... 5-23  
 Create Report button..... 5-19, 6-16, 6-32  
 Cumulative Variance Capture..... 8-22  
 Custom... ..... 8-4  
 cuvette.. 1-4, 4-11, 7-2, 9-1-2, 11-7, 11-9, 11-11

---

## D

danger to fingers notice ..... 0-6  
 dark current..... 1-2  
 Dark Offset checkbox..... 7-2  
 dark noise..... 9-9, 9-11  
 .DAT files ..... 8-19  
 Data column..... 8-9  
**DataSet Editor** window ..... 8-25  
 Declaration of Conformity ..... 14-1  
 DECOMPOSITION ..... 8-2  
 DECOMPOSITION header ..... 8-18  
 de-ionized water ..... 4-11, 9-1, 10-13  
 Delay before executing field..... 5-15  
 Delay before first field..... 5-15

Delay between each field.....5-15  
 Delay between each repeat list field ..5-15  
 Delay Remaining.....5-36  
 Delays area.....5-34  
 Delete button.....5-14  
 detector..... 1-2, 3-2, 3-6, 7-1, 9-4, 12-1  
 Detectors icon .....7-7  
 Device Id field .....7-8  
 Dewar flask .....11-3  
**dimensions** .....12-3  
 disclaimer.....0-3  
 dispersion ..... 3-4, 12-2  
**Display Data** window.....8-11  
 dissolved solids .....9-3  
 Double Spectrometer area .....10-16  
 Down button .....5-14  
 Dual-Position Thermostatted Cell Holder11-8  
 DVD.....2-7

---

**E**

Edit.....8-14  
 Edit All Settings button .....8-12  
 Edit Data ..... 8-20, 8-25  
 EEM... 1-2-6, 5-3, 5-18-19, 5-30, 5-37, 5-39,  
 6-1, 6-9, 6-16, 6-26, 6-32, 8-5-6, 8-9, 8-  
 23, 9-10-11  
 EEM 3D + Absorbance..... 6-9, 6-26  
**EEM Filter Settings** window .....8-5-6  
 EEM Filtering .....8-5  
 electric shock notice.....0-6  
 electrical requirements .....2-4  
 electronics ..... 3-6, 7-2  
 elliptical mirror .....3-3  
 Emission 2D..... 6-6, 10-15  
 emission scan ..... 5-2, 6-25  
 Emulate button.....2-10  
 emulation .....2-9  
 Enable External Trigger checkbox .....5-24  
 environmental requirements .....2-3  
 ethylene-glycol..... 11-6, 11-8, 11-10  
 excessive humidity notice .....0-6  
 excitation-emission map ..... 1-2  
 excitation scan.....6-25  
 Excitation Wavelength.....6-19  
 Execution List .....5-14-15  
 Experiment Menu button.2-9, 5-2-3, 6-2, 6-  
 6, 6-9, 6-18, 6-21, 6-25

**Experiment Paused** window5-18, 6-19-20, 6-  
 22  
**Experiment Setup** window .. 5-17, 7-1, 7-6, 9-  
 6-8, 10-15  
**Experiment Status** window . 4-6, 4-9, 4-14, 4-  
 17, 4-20, 4-23, 5-18, 5-38, 6-7, 6-10, 6-19,  
 6-26  
 explosion notice.....0-6  
 Export Options area..... 5-26  
 extinction coefficient..... 1-3  
 extreme cold notice .....0-5

---

**F**

F-3030 ..... 11-16  
 F4-3000 ..... 11-5  
 face-shield ..... 0-7  
 Fiber Optic Mount ..... 11-5  
 fiber-optic bundle ..... 11-5  
**Figure 1 PARAFAC** ..... 8-7  
 File..... 5-29-30  
 File field ..... 5-4  
 File Name field ..... 5-14  
 Files of type drop-down menu..... 5-29  
 filter .....10-1, 10-21-22  
 filter-assembly ..... 10-22  
 filter wheel..... 7-3  
 First Order Rayleigh Filter checkbox ... 8-5  
**Fitting PARAFAC** progress bar ..... 8-16  
 FL-1013 ..... 11-3  
 FL4-1011 ..... 11-6  
 FL4-1012 ..... 11-8  
 FL4-1015 ..... 11-15  
 FL4-1027 ..... 11-10  
 flow chart..... 1-6  
 Fluorescence Correction (NIST SRM  
 2941)..... 4-15  
 Fluorescence Correction (NIST SRM  
 2942)..... 4-18  
 Fluorescence Correction (NIST SRM  
 2943)..... 4-21  
 FM-2003 ..... 11-6, 11-8, 11-10  
 Four-Position Thermostatted Cell Holder11-6  
 fused silica..... 11-3-4  
 fuses.....2-4, 12-3  
 F(Y) column ..... 4-10

---

**G**

Gain ..... 9-11  
 gamma-ray spikes ..... 9-9  
 goodness-of-fit ..... 8-10  
 grating ..... 3-4, 12-2

---

**H**

Half-Width field ..... 8-5  
 help ..... 9-7  
 Help ..... 7-4  
 highly opaque samples ..... 9-2  
**HJY\_normalize** window ..... 5-12, 6-14, 6-30  
 Horiba JY Aqualog File (DAT) 8-3, 8-19, 8-24, 8-26  
 Horiba JY Aqualog File (DAT) file type 8-3  
 Horiba JY Aqualog File (DAT) type .... 8-19  
 host computer .. 0-1, 2-4-5, 2-7-9, 3-2, 3-7, 4-2, 5-9-10, 5-13, 7-3, 8-2, 10-1-2, 12-1, 12-4  
 hot equipment notice ..... 0-6  
 Hotelling plot ..... 8-28  
 hour-meter ..... 10-13, 10-21  
 HPLC Flow Cell ..... 11-4

---

**I**

IFE ..... 1-1, 1-4-5  
**Import** window ..... 8-3, 8-19, 8-24, 8-26  
 Increment ..... 6-7, 6-10, 6-19, 6-26  
 Increment drop-down menu .. 5-17, 5-37, 9-8  
 Injector Port ..... 11-15  
 inner-filter corrections ..... 9-2  
 inner-filter effect .. 1-1-2, 5-9-10, 5-13, 6-13, 6-29  
 Input Values button ..... 6-16, 6-32  
**Input Values** window ..... 5-19, 6-16, 6-32  
**Insert Sample** window ..... 5-27  
**Installed Components** window ..... 7-5  
 instrument configuration ..... 5-27  
 integrating sphere ..... 5-2  
 integration time ..... 5-18, 9-5-6, 12-2  
 Integration Time ..... 5-18, 5-24, 5-39, 6-19  
 intense light notice ..... 0-5  
 Intercept ..... 6-23  
 Intercept sd ..... 6-23

**Intermediate Display** 5-5, 5-8, 5-28, 5-35-36, 6-3-4, 6-8, 6-11, 6-27  
 interruption ..... 5-31, 5-33  
 Interval ..... 6-19  
 IR sensor ..... 7-3

---

**J**

J1933 ..... 9-2, 11-12  
 J356947 ..... 10-21  
 J980087 ..... 2-5  
 Jobin Yvon ..... 10-13  
**JY Rayleigh Masking User Input** window ... 5-10, 6-13, 6-30  
 .jyb file ..... 5-14

---

**K**

K<sub>2</sub>Cr<sub>2</sub>O<sub>7</sub> blank ..... 4-5-6, 4-8  
 K<sub>2</sub>Cr<sub>2</sub>O<sub>7</sub> sample ..... 4-9  
 kinetics ..... 11-15  
 Kinetics button ..... 6-18  
 kinetics run ..... 5-2  
 Kinetics spectra ..... 6-1, 6-18

---

**L**

**Lamp hours** warning notice ..... 10-1  
 lamp housing ..... 10-2, 10-4-5  
**Lamp Info** window ..... 10-14  
 lamp replacement ..... 10-1  
 Lamp Reset ..... 10-13  
 leveling feet ..... 2-6  
 liquid nitrogen ..... 11-3  
 Liquid Nitrogen Dewar Assembly ..... 11-3  
 Load button ..... 5-14, 8-15  
**Loading Surfaces** window ..... 8-11  
 Loadings M1 ..... 8-8  
 log file ..... 5-29, 5-31, 5-33  
 Lorentzian distribution ..... 9-8

---

**M**

magnetic stirrer ..... 3-5, 11-4, 11-6-11  
 maintenance ..... 10-1  
 Material Safety Data Sheets ..... 0-3

MatLab® console ..... 1-5  
 maximum temperature fluctuation ..... 2-3  
*M*<sub>correct</sub> ..... 1-2  
 Method Options ..... 8-14  
 MgF<sub>2</sub> ..... 3-4  
 Model button ..... 8-6, 8-21  
 monochromator 3-1, 3-3-5, 4-1, 4-3, 5-2, 7-1,  
 7-3, 9-4, 10-6, 11-5, 11-12-13, 12-1-2  
 monolayers ..... 9-2  
 MSDS ..... 0-3  
**Multiple Fluoromax Files – DataSet Editor**  
 window ..... 8-20

---

## N

Next >> button 2-10-11, 5-3, 6-2, 6-6, 6-9, 6-  
 18, 6-26, 10-15  
 NIST ..... 4-15  
 nitric acid ..... 9-1  
**No Y-block** warning window ..... 8-26  
 nonnegativity ..... 8-15  
 Normalize button ..... 5-12, 6-14, 6-30  
 normalizing EEM data ..... 5-37  
 Notes (\*.txt) ..... 5-29  
 Number Components field ..... 8-6  
 Number of Blank Groups ..... 5-25  
 number of components ..... 8-6  
 Number of Standards ..... 6-22  
 Number of Unknowns ..... 6-22  
 N-way Toolbox ..... 1-5

---

## O

.ogw workbook format ..... 5-26, 5-30  
 OK button 4-6, 4-9, 4-14, 4-17, 4-20, 4-23, 5-  
 5, 5-10, 5-12, 5-18, 5-24-25, 5-27, 5-29, 5-  
 33, 6-3-5, 6-7-8, 6-10-11, 6-13-14, 6-16,  
 6-20, 6-22-23, 6-27, 6-30-32, 7-5, 7-8, 8-  
 3, 8-6, 8-12-13, 8-15, 8-19, 8-21, 8-24, 8-  
 26, 10-1, 10-14  
 Open button . 5-23, 5-29-30, 8-3, 8-19, 8-25,  
 8-27, 10-17  
**Open** window ..... 5-29  
 Open ..... 5-29-30  
 optical layout ..... 3-3  
 Options ..... 8-14  
**Options/Preferences** window ..... 8-12, 8-14

Origin® ..... 0-1, 5-5, 5-8, 5-16, 5-30, 7-5  
 Output File Names area ..... 5-25  
 Output Files ..... 5-34  
 Output Folder area ..... 5-25  
**Output Parameters Validation** window ... 5-34  
 ozone ..... 10-21

---

## P

PARAFAC ..... 1-5, 8-1-2, 8-6, 8-18, 9-12  
 PARAFAC – Parallel Factor Analysis .. 8-2  
**PARAFAC** window ..... 8-16  
 Parallel-Factor Analysis ..... 8-1  
 Parameters column ..... 8-8  
 PCA ..... 8-1  
 PCA – Principal Component Analysis 8-18  
 Perform Split-Half Analysis button ..... 8-16  
 Performance Test Report ..... 4-3  
**Performing Split Half Analysis** progress bar 8-  
 16  
 Phillips screwdriver ..... 10-1  
 photobleaching ..... 1-1, 3-4, 9-8  
 photodiode ..... 3-6, 12-2, 12-3  
 pixel-binning ..... 5-17, 6-7, 6-10, 6-26, 9-5  
**Please Change Samples** window .. 5-27, 5-35  
 Plot 2D Loading Surfaces button ..... 8-11  
 Plot button ..... 8-22  
**Plot Control** window ..... 8-28  
**Plot Controls** window ..... 8-11-12, 8-22  
 Plot Data Estimate and Residuals button  
 ..... 8-11  
 Plot Eigenvalues/Cross-validation  
 Results button ..... 8-21  
 Plot Scores and Sample Statistics button  
 ..... 8-28  
 plottype ..... 8-13  
 Position field ..... 10-16  
 Post Processing Options area ..... 5-26  
 potassium bromide ..... 9-2  
 powder ..... 9-2, 11-12  
 power cord ..... 2-6, 10-2  
 power supply ..... 7-1-2, 10-2  
 power switch ..... 4-1-2  
 Prediction button ..... 8-27  
 Preprocess ..... 8-4  
**Preprocessing X-block** window ..... 8-4, 8-6  
 Previous Experiment Setup button ..... 5-6  
 Principal-Components Analysis ..... 8-1, 8-18

Print Info button ..... 7-5  
 Processed Graph IFE tab ..... 5-9  
 Processed Graph NRM tab ..... 5-13  
 Processed Graph RM ..... 5-10  
 Profile button ..... 6-15, 6-32  
 Profile Tool button ..... 5-19  
**Project name** window 4-6, 4-9, 4-14, 4-17, 4-20, 4-23, 5-5, 5-18, 5-38, 6-4, 6-20, 6-23  
 protective gloves ..... 0-6

---

## Q

QSU ..... 1-5  
 QSU Adjust value ..... 5-18  
 quantum yields ..... 9-5  
 Quartz Cuvette ..... 11-4  
 quartz window ..... 3-3  
 queue ..... 5-22, 5-27  
 Quinine Sulfate blank ..... 5-18  
 Quinine Sulfate button ..... 5-37  
 Quinine Sulfate sample ..... 5-18  
 quinine sulfate solution ..... 6-18, 6-21  
 Quinine Sulfate standard kit ..... 5-17  
 quinine sulfate unit ..... 1-4-5  
 Quinine Sulfate Units button ..... 5-17

---

## R

R ..... 1-2  
 Raman Filter checkbox ..... 8-5  
 Raman mask ..... 8-4  
 Raman scattering ..... 1-3-5  
 Raman Scattering Area Unit button ... 5-37  
 Raman Shift field ..... 8-5  
 Raw data thumbnail ..... 8-9  
 Rayleigh lines ..... 8-4  
 Rayleigh masking ..... 1-3, 9-11  
 Rayleigh Masking button ..... 5-10, 6-13, 6-30  
 Rayleigh-masking tool ..... 7-2, 9-11  
 Rayleigh scattering ..... 1-3, 5-10  
 $R_c$  ..... 1-2  
 read this manual notice ..... 0-6  
 readout noise ..... 9-8-9  
**Real Time Control** .... 7-1, 7-6, 9-6, 10-15, 10-18-19  
 reference detector 1-2-3, 3-2, 3-5-6, 7-1, 12-1  
 REGRESSION header ..... 8-23

relative humidity ..... 2-3, 12-3  
 Remind Later button ..... 10-21  
 Res. Sum. Sq. M1 thumbnail ..... 8-10  
 Rescale Y button ..... 5-21  
 Reset Lamp button ..... 10-13  
 Reset Now button ..... 10-21  
 Reshape ..... 8-20, 8-25  
**Reshape Data** window ..... 8-20, 8-25  
 Residuals column ..... 8-10  
 Residuals thumbnail ..... 8-10  
 resolution ..... 12-2  
 Resume button ..... 5-32  
 RM-06HLKI-R ..... 4-7  
 RMS noise ..... 4-24  
 RoHS Declaration of Conformity ..... 0-13  
 RSU Adjust values ..... 5-39  
 RSU-Adjust tab ..... 5-39  
 RTC button ..... 7-6, 10-15  
 Run button... 4-5, 4-8, 4-13, 4-16, 4-19, 4-22, 5-4, 5-7, 5-15, 5-17, 5-27, 5-34, 5-38, 6-3, 6-7, 6-10, 6-19, 6-22, 6-26, 10-17  
 Run JY Batch Experiments button ..... 5-14

---

## S

S ..... 1-2  
 S1c/R1c signal ..... 9-11  
 S/N ..... 4-24, 9-5-7, 9-9-10, 9-12  
 S/R ..... 1-2  
 safety goggles ..... 0-6  
 safety summary ..... 0-5  
 safety-training requirements ..... 2-1  
 Sample - Blank Contour Plot tab 6-12, 6-28  
 Sample - Blank Processed checkbox. 5-26  
 Sample - Blank Processed results ..... 5-26  
 Sample Cell ..... 11-4  
 sample changer 6-2-4, 6-6, 6-7, 6-9-10, 6-18, 6-21, 6-25, 6-27  
 sample compartment.. 3-5, 4-11, 4-13, 5-4, 5-18, 5-27, 5-35-36, 6-2-4, 6-6, 6-9, 6-18, 6-21, 6-23, 6-25, 7-2, 10-3, 10-13, 11-5, 11-15  
 Sample Compartment Accessory .. 11-6, 11-8, 11-10  
 sample-compartment lid . 4-6, 4-9, 4-14, 4-17, 4-20, 4-23, 5-18, 6-20, 6-27  
 sample mount ..... 10-2  
 sample platform ..... 3-5

- sample preparation.....9-2  
 Sample Queue button ..... 5-22, 5-34  
**Sample Queue Setup** window .. 5-22, 5-24, 5-26, 5-34  
 Sample Queue tool.....8-1  
 Sample Setup area.....5-25  
 Sample Start #.....5-26  
 sample turret ..... 3-5, 7-1, 7-3  
 Samples area .....6-22  
 Samples table .....6-22  
 Save button ..... 5-14, 5-24  
 Save To File... button .....7-5  
 $S_c$  ..... 1-3  
 scan speed ..... 12-2  
 scattered light.....9-9  
 Second Order Rayleigh Filter checkbox 8-5  
 Select button .....8-11–12  
**Select File to Open** window .. 8-3, 8-19, 8-24, 8-26  
 Selected Methods list .....8-6  
 sensitivity ..... 4-24, 12-2  
 serial number..... 4-9, 10-8, 10-14  
 Service Department.. 4-6, 4-10, 4-14, 4-17, 4-20, 4-23, 7-1–4, 7-8  
**Setup batch experiments** window .....5-14  
 shutter..... 3-4, 7-1, 12-2  
 Shutter Mode slide-switch .....10-17  
 signal-to-noise ratio ..... 4-24, 9-5  
 Single Cell Kinetics checkbox.....5-34  
**Single Channel Advanced Parameters**  
 window .....7-8  
 Single Point Absorbance experiment..9-11  
 Single Point button.....6-21  
 Single Point Std tab .....6-23  
 Single-point spectra ..... 6-1, 6-21  
 Single-Position Thermostatted Cell Holder  
 .....11-10  
**slit width** ..... 12-2  
 slits ..... 3-4, 9-4  
 Slope .....6-23  
 Slope sd.....6-23  
 small-volume samples.....9-2  
 SN.....4-9  
 softkey device .....2-8  
 Solid-sample holder .....7-2, 9-2, 9-4, 11-12  
 solid samples.....9-2–3  
 Solo icon.....8-2  
 Solo software .....8-1, 9-11  
 Solo+MIA icon.....5-31  
**Solo+MIA Workspace Browser** window... 8-2, 8-18, 8-23  
 special buttons ..... 5-1  
 special sample holder ..... 4-13  
 Spectra button ..... 6-2, 6-6, 10-14  
 SpectrAcq firmware version.....7-6  
 spectral correction-factors ..... 1-2  
**Split Half Analysis Results** window..... 8-16  
 SRM 2941.....4-15  
 SRM 2942.....4-15  
 SRM 2943.....4-15  
 Standard.....6-23  
 Starna Cells, Inc. ....4-7  
 Starna RM sample ..... 4-4  
 Starna sealed water-Raman sample..... 4-11  
 Start menu..... 10-13  
 stirring bar ..... 7-2  
**stray light**..... 12-3  
 surface requirements.....2-2  
 Switch menu between HJY Software  
 Application and Origin Std. button .. 5-16  
 system configuration ..... 7-6  
**System Initialization Process** window..... 2-9
- 
- T**
- Teflon® .....11-3–4, 11-12  
 temperature bath...5-2, 11-6, 11-8, 11-10, 11-16  
 thin films.....9-2, 11-12–13  
 This plot in separate window message.. 8-8  
 three-dimensional absorbance scan ..... 6-25  
 three-dimensional emission spectra....6-1, 6-9  
 toolbar 5-6, 5-9–10, 5-12, 5-17, 5-19, 5-21, 7-4  
 Total Repeats field..... 5-15  
 Transform.....8-20, 8-25  
 trigger accessory..... 2-6  
 trigger cable..... 2-6  
 TRIGGER IN connector ..... 2-6  
 troubleshooting.....7-1, 8-1  
 turning on the system ..... 4-2  
 two-dimensional emission spectra.....6-1, 6-6

---

**U**

ultraviolet light notice ..... 0-5  
 unfold ..... 8-26  
 unfolding ..... 8-19  
**Unknown chart** ..... 6-24  
 unpacking and installation ..... 2-5  
 Up button ..... 5-14  
 USB cable ..... 2-6, 2-7, 7-2-3, 10-2  
 USB port ..... 7-3  
 Utilities ..... 10-13  
**UV Filter Warning** window ..... 10-21

---

**V**

Value drop-down menu ..... 8-15  
 View Labels on/off button ..... 8-9  
 View Model Details button ..... 8-7  
 View System Info button ..... 7-5, 8-11

---

**W**

**Waiting for Experiment Delay** window... 5-36  
 warning notice ..... 0-5  
**Warning Replacing Missing Data** window. 8-21  
 Waste Electrical and Electronic Equipment 0-14  
 water-Raman peak ..... 5-38  
**Water Raman SNR and Emission**  
   Calibration ..... 4-12  
 water Raman spectrum ..... 10-1, 12-2  
 Wavelength list ..... 6-22  
 Wavelength settings ..... 5-24  
 Wavelengths area ..... 6-22  
 WEEE ..... 0-14  
 Windows® 0-1, 2-7, 3-7, 4-2, 7-3, 10-13, 12-4  
 workbook ..... 5-25, 5-30

---

**X**

X button ..... 8-3-4, 8-19-20, 8-24-26, 8-29  
 X-block ..... 8-4  
 xenon lamp 0-10-11, 3-3, 3-6, 4-1, 7-2, 10-1-2, 10-6, 10-18-19, 11-14, 12-2  
 xenon-lamp bulbs ..... 2-1  
 xenon-lamp scan ..... 10-1

X<sub>correct</sub> ..... 1-2  
 .xml ..... 5-14

---

**Y**

Yes button ..... 5-35, 8-26

---

**Z**

Zip Info button ..... 7-5



# **HORIBA**

## **Scientific**

3880 Park Avenue, Edison, New Jersey 08820-3012, USA  
[www.horiba.com/scientific](http://www.horiba.com/scientific)

---

[Design Concept]

The HORIBA Group application images are collaged in the overall design.  
Beginning from a nano size element, the scale of the story develops all the way to the Earth with a gentle flow of the water.

